

Safety Instructions & Operators Manual

COUNTRY CLIPPER

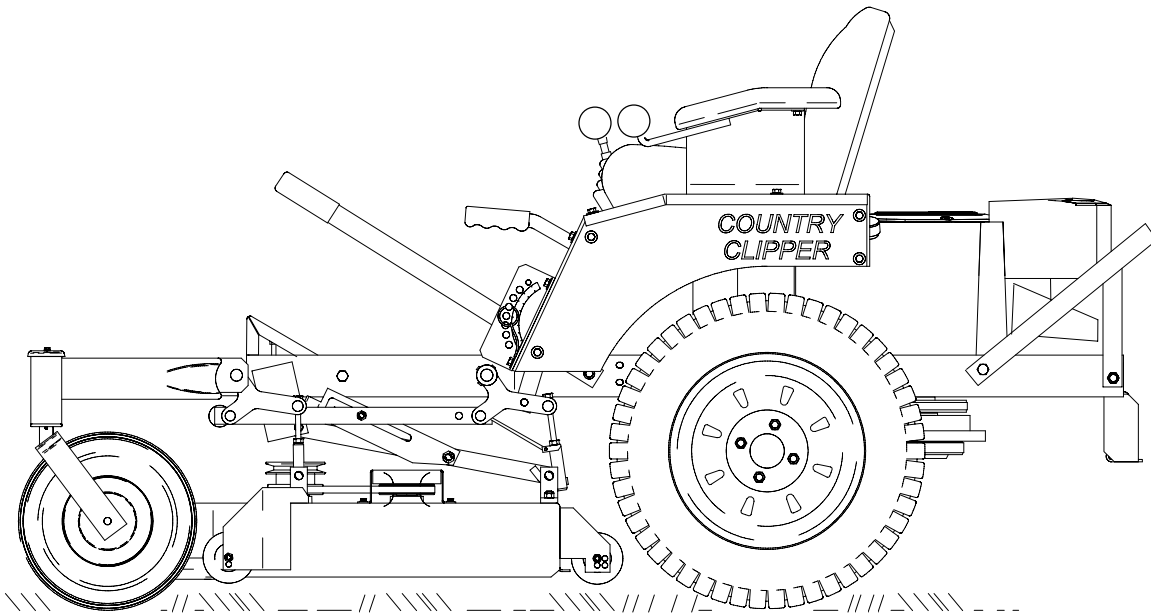

Congratulations for buying a **Country Clipper** product. Your **Country Clipper** Zero Turning Radius Riding Mower was designed and built to provide long and trouble free service. Keep in mind that it, like any other mechanical device, can be potentially dangerous if used improperly, and hazard control and accident prevention are dependent upon the awareness, concern, prudence, and proper training of personnel involved in the operation, transport, maintenance, and storage of the equipment. Study this manual and pay special attention to the important Safety Precautions on pages 4-6. Following these instructions will help you continue to enjoy the trouble-free performance expected of the **Country Clipper** product.

TABLE OF CONTENTS

I. OWNER INFORMATION

Warranty Information	2
----------------------------	---

II. SAFETY

Accident Patterns	4
Safety Instructions and Recommendation	4
Safety Interlock Systems	6
Operation	7

III. START UP AND OPERATION

Checklist Before Operation	6
Joystick Steering Operation.....	7
Twinstick Steering Operation.....	7
Mowing Recommendations	9

IV. SPECIFICATIONS

9

V. MAINTENANCE

Maintenance Schedule	10
Maintenance Instructions	11
Raising and Lowering Deck for Servicing	16
Leveling the Deck	17
Trouble Shooting Checklist	18
Wiring Schematic for Joystick Model	20
Wiring schematic for Twinstick Model.....	21

SAFETY

ACCIDENT PATTERNS TO AVOID

- I. **CONTACT WITH THE ROTATING BLADE** -- This accident usually happens when the operator is clearing the discharge chute of grass, (especially when the grass is wet), or when the operator adjusts the machine without turning it off and waiting for the blades to completely stop.
- II. **PROPELLED OBJECTS** -- Sticks, rocks, wires and other objects can be propelled out through the discharge chute or from under the mower housing. Bystanders are particularly vulnerable.
- III. **GRASS CATCHER OR GUARD** -- The mower shall not be operated without either the entire grass-catcher or guard in place.
- IV. **OVERTURNING** -- This happens when riding mowers are used on steep slopes, embankments or hills. The operator in these cases can come in contact with the blades or sustain injuries during a fall.
- V. **MOWER RUNNING OVER THE VICTIM** -- This usually happens when a riding mower is driven in reverse. The accident victims are most often young children whom, unseen by the operator of the mower, were in the area being mowed.

AT **COUNTRY CLIPPER**, WE SHARE YOUR DESIRE TO PROTECT YOURSELF, YOUR FAMILY, YOUR FRIENDS AND YOUR NEIGHBORS FROM ACCIDENTAL INJURY. OBSERVING AND ENFORCING THE FOLLOWING GUIDELINES WILL HELP TO INSURE THE SAFETY OF EVERYONE.

PLEASE BE CAREFUL!

SAFETY INSTRUCTIONS AND RECOMMENDATIONS

1. **PEOPLE WHO OPERATE, SERVICE, OR ARE OTHERWISE ASSOCIATED** with the ***Country Clipper*** Zero Turning Radius Mower should be trained in its proper use and warned of its dangers. Before operating, adjusting, or servicing the ***Country Clipper*** Zero Turning Radius Mower they should read and understand this entire manual and the engine owner's manual.
2. **AVOID CONTACT WITH MOVING PARTS.** Keep hands and feet from under mowing deck and away from blades at all times. Turn engine (motor) off if you must unclog the chute.
3. **AVOID HILLS AND SLOPES.** Use extreme caution when mowing up or down slopes. NEVER mow across the face of a slope. If a slope must be ascended, back up the slope; drive forward when descending. Reduce speed and use caution to start, stop and maneuver. To prevent a loss of control on a slope avoid sharp turns, sudden changes in direction, and sudden stops and starts.
4. **DISENGAGE POWER TO MOWER BEFORE BACKING UP.** Do not mow in reverse unless ABSOLUTELY necessary and then only after turning around and observing the entire area behind the mower. Go slowly. Most "running over victim" accidents occur in reverse.
5. **BEGINNING OPERATORS SHOULD LEARN HOW TO STEER** the ***Country Clipper*** Zero Turning Radius Mower before attempting to mow. Start with a slow engine speed and drive without the blades engaged in an open area until comfortable with the machine.
6. **KNOW HOW TO STOP QUICKLY.** KNOW THE LOCATION AND OPERATION OF EVERY CONTROL, ESPECIALLY HOW TO BRAKE AND DISENGAGE THE MOWER BLADES.

7. **DO NOT MOVE CONTROL LEVER(S)** from forward position to reverse position rapidly. The speed and/or direction of travel are affected instantly by movement of the Control Lever(s).
8. **DO NOT ALLOW CHILDREN TO OPERATE MOWER.** Do not allow others who have not had instruction to operate mower.
9. **ALWAYS TURN THE ENGINE OFF AND REMOVE KEY** before leaving the mower to prevent children and inexperienced operators from starting the engine. Never leave the mower unattended with engine running. Always wait for all moving parts and all sounds to stop before leaving operator's seat.
10. **WEAR STURDY, ROUGH-SOLED WORK SHOES AND CLOSE-FITTING SLACKS AND SHIRTS.** Never operate mower in bare feet, sandals or sneakers.
11. **NEVER CARRY PASSENGERS.**
12. **KNOW THE AREA YOU ARE TO MOW.** Watch for hidden danger such as rocks, roots, sticks, holes, bumps, and drop-offs, etc. Before mowing, pick up all debris in area to be mowed. Sharp and hard objects can be propelled at a high speed and can act like shrapnel. Walk through tall grass **BEFORE MOWING** to make sure there are no hidden dangers. Mow higher than desired in tall grass to expose any hidden objects and/or obstacles, clean the area, and then mow to the desired height.
13. **NEVER REFUEL A MOWER INDOORS.** Allow the engine time to cool before refueling. Unseen vapors may be ignited by a spark. Always clean up spilled gasoline. Never run the engine indoors in a garage or any other closed building. Allow engine to cool before storing in any enclosure. The engine exhaust and gasoline fumes are dangerous.
14. **NEVER REMOVE THE FUEL CAP** or add gasoline to a running or hot engine that has not been allowed to cool for several minutes after running. Always make sure the gas cap is in place.
15. **DO NOT SMOKE AROUND THE MOWER** or the gasoline storage container. Gasoline fumes can easily ignite.
16. **KEEP GASOLINE IN A WELL-VENTILATED AREA** away from your living quarters and in tightly -capped safety cans. Never store mower with gasoline in the tank inside a building where fumes may reach open flame or spark.
17. **DISENGAGE BLADES, STOP ENGINE AND REMOVE IGNITION KEY** before any servicing. Be sure all moving parts and all sounds have stopped. Let engine cool and disconnect the spark plugs so the engine cannot start by accident. A SLIGHT ROTATION OF THE BLADES COULD START THE ENGINE.
18. **KEEP ALL NUTS, BOLTS, AND SCREWS TIGHT** to be sure equipment is in safe working condition, especially blade mounting bolts.
19. **VEHICLE SHOULD BE STOPPED AND INSPECTED FOR DAMAGE** after striking a foreign object and the damage should be repaired before restarting and operating the equipment. Stop immediately and check for damage or loose parts if mower should start vibrating.
20. **DISENGAGE BLADES BEFORE DRIVING ACROSS WALKS** or projecting objects.
21. **KEEP SAFETY DEVICES AND GUARDS IN PLACE.** If any of the safety switches become inoperable, have them repaired immediately.
22. **DO NOT STEP OR STAND ON THE MOWER HOUSING.** Step or stand only on the foot deck.
23. **WATCH OUT FOR TRAFFIC** near roadways and when crossing roads.
24. **DO NOT USE MOWER WHEN GRASS IS WET AND SLIPPERY.**

- 25. **MOW ONLY DURING DAYLIGHT.**
- 26. **THIS MACHINE IS NOT MEANT FOR HIGHWAY OR STREET USE.** It is not a recreational vehicle and it should not be operated as such.
- 27. **ALWAYS DISENGAGE THE MOWER BLADE CLUTCH** when transporting.

SAFETY INTERLOCK SYSTEM

Your *Country Clipper* Zero Turning Radius Mower is equipped with switches interlocked for your safety.

ON JOYSTICK MODELS NEUTRAL IS WHEN THE JOYSTICK IS IN THE “**DOWN**” POSITION.



ON TWIN STICK MODELS NEUTRAL IS WHEN BOTH HANDLES ARE IN THE “**OUT**” POSITION.

- 1. The mower blades must be disengaged before engine will start.
- 2. The Control Lever(s) must be in the neutral position before the engine will start.
- 3. The engine will stop if the mower blade clutch is engaged when the operator leaves the driver’s seat.
- 4. The engine will stop if the Control Lever(s) are not in the neutral position when the operator leaves the driver’s seat.
- 5. The engine will stop if the brake is “**SET**” and the Control Lever(s) are not in the neutral position.
- 6. The engine will stop if the brake is “**SET**” and the mower blade clutch is engaged.

DO NOT OPERATE MOWER IF SAFETY SWITCHES ARE NOT OPERATING PROPERLY

CHECKLIST BEFORE OPERATION

- 1. Make sure fuel tank is full. Use regular unleaded gasoline (see engine owner’s manual for more details).

WARNING

HANDLE GASOLINE WITH CARE -- IT IS HIGHLY FLAMMABLE. DO NOT SMOKE. ENGINE SHOULD BE OFF AND COOL. USE APPROVED GAS CONTAINER. NEVER FILL TANK INDOORS. WIPE UP ANY SPILLS. REPLACE CAP TIGHTLY.

- 2. Make sure dirt and foreign matter is kept out of gas tank. Use a clean funnel and gas can.
- 3. Do not mix oil with gasoline.
- 4. Do not use white, high test or premium gasoline. Do not use de-icers, carburetor cleaners, or other such additives.
- 5. Check the crankcase oil level. Make sure the engine is off. The mower should be parked on a level area. Do not overfill. (See your engine manual for more detailed instruction.)
- 6. Check the hydrostatic transmission oil level. (See “Maintenance” section of this manual.)
- 7. Check battery fluid level.
- 8. Inspect V-belts.
- 9. Check tire pressure:

Model	Front tires	Rear tires
All Models	12 psi	12 psi
- 10. Make sure underside of mower deck is free of grass.
- 11. Make sure mower blades are sharp and secured tightly.

JOYSTICK STEERING INFORMATION

12. Clean the air intake screen on the engine if necessary.
13. Perform any other maintenance as it becomes necessary. (See the "Maintenance" section of this manual.)

IMPORTANT: Before cutting grass, clutch must be broken-in as follows: With engine at full RPM engage deck until blades come to full speed and then disengage until blades come to a complete stop. Repeat 10 times to seat clutch properly.

CONTROL LOCATIONS

Joystick Control Lever

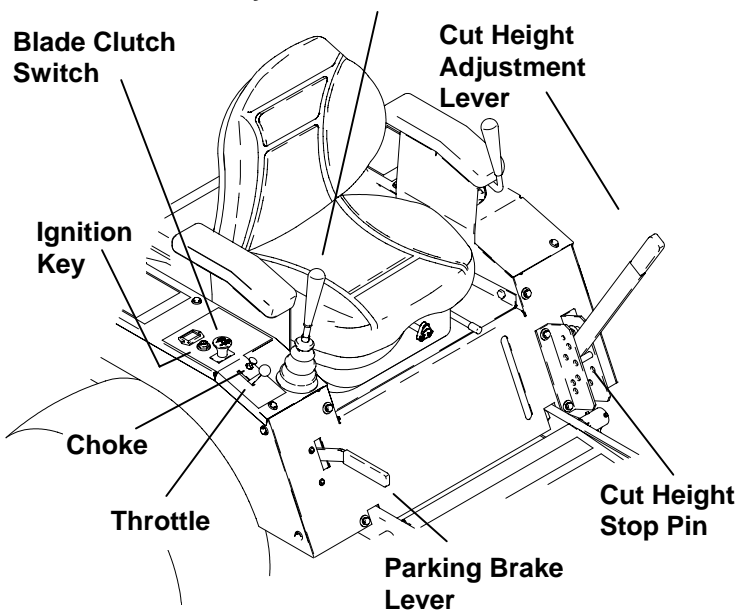

! WARNING !

AVOID INHALING EXHAUST FUMES -- CARBON MONOXIDE GAS IS COLORLESS AND ODORLESS, AND CAN CAUSE UNCONSCIOUSNESS, AND IS POTENTIALLY LETHAL. DO NOT RUN LAWN MOWER IN GARAGE OR OTHER CONFINED AREA.

OPERATION

1. MOVE JOYSTICK CONTROL LEVER TO neutral "DOWN" position.
2. SET PARKING BRAKE. Pull up to set.
3. DISENGAGE MOWER BLADE CLUTCH by moving clutch switch to "OFF" position.

PULL ENGINE CHOKE CONTROL to full position for cold starts

5. SET ENGINE THROTTLE TO 1/2 THROTTLE.
6. TURN IGNITION KEY to "START" position and release to "RUN" as soon as engine starts. NOTE: Prolonged cranking will damage starter motor and shorten the battery life.
7. ADJUST ENGINE THROTTLE AND CHOKE for desired engine smoothness and speed.
NOTE: When mowing, always run engine at full throttle.
8. RELEASE PARKING BRAKE. Push brake lever down to release.

IMPORTANT: Until the operator is familiar with the **Country Clipper** Zero Turning Radius Mower, he/she should follow these recommendations: Disengage the mower blades. Go very slowly until thoroughly familiar with the machine. Keep away from fences, buildings, and other obstructions. Move the Joystick Control Lever smoothly and slowly. Practice until operation is smooth and efficient.

10. TO DRIVE: Move the Joystick Control Lever to the "UP" position. Move the Joystick Control Lever forward to move forward. Increasing forward movement of the Joystick Control Lever will increase the speed of travel. To reverse the direction, pull the Joystick Control Lever slightly back. To turn, move the Joystick Control Lever toward the direction you want to turn. To turn on a zero radius axis, go slowly and move the Joystick Control Lever to the side you wish to turn and slightly to the rear at the same time.

TWINSTICK STEERING INFORMATION

- Clean the air intake screen on the engine if necessary.
- Perform any other maintenance as it becomes necessary. (See the "Maintenance" section of this manual.)

IMPORTANT: Before cutting grass, clutch must be broken-in as follows: With engine at full RPM engage deck until blades come to full speed and then disengage until blades come to a complete stop. Repeat 10 times to seat clutch properly.

CONTROL LOCATIONS

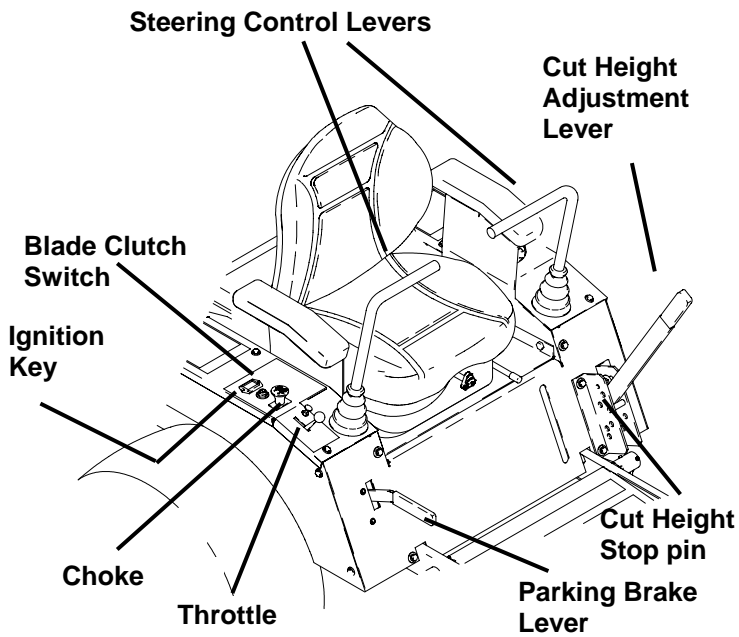

⚠ WARNING ⚠

AVOID INHALING EXHAUST FUMES -- CARBON MONOXIDE GAS IS COLORLESS AND ODORLESS, AND CAN CAUSE UNCONSCIOUSNESS, AND IS POTENTIALLY LETHAL. DO NOT RUN LAWN MOWER IN GARAGE OR OTHER CONFINED AREA.

OPERATION

- MOVE STEERING CONTROL LEVERS TO neutral "OUT" position.
- SET PARKING BRAKE. Pull up to set.

3. DISENGAGE MOWER BLADE CLUTCH by moving clutch switch to "OFF" position. PULL ENGINE CHOKE CONTROL to full position for cold starts.
5. SET ENGINE THROTTLE TO 1/2 THROTTLE.
6. TURN IGNITION KEY to "START" position and release to "RUN" as soon as engine starts. NOTE: Prolonged cranking will damage starter motor and shorten the battery life.
7. ADJUST ENGINE THROTTLE AND CHOKE for desired engine smoothness and speed. NOTE: When mowing, always run engine at full throttle.
8. RELEASE PARKING BRAKE. Push brake lever down to release.

IMPORTANT: Until the operator is familiar with the Zero Turning Radius Mower, he/she should follow these recommendations. Disengage the mower blades. Go very slowly until thoroughly familiar with the machine. Keep away from fences, buildings, and other obstructions. Move the Steering Control Levers smoothly and slowly. Practice until operation is smooth and efficient.

10. TO DRIVE: Move the Steering Control Levers to the "IN" position. Move the Steering Control Levers forward to move forward. Increasing forward movement of the Steering Control Levers will increase the speed of travel. To reverse the direction, pull the Steering Control Levers slightly back. To turn, move one Steering Control Lever slightly ahead of the other. To turn on a zero radius axis, go slowly and move one Steering Control Lever forward and one Steering Control Lever rearward. (For a right hand turn the left hand Steering Control Lever will be ahead of the right hand Steering Control. For a left hand turn the right hand Steering control will be ahead of the left hand Steering Control.)



CAUTION



FOR SMOOTH, SAFE OPERATION, MOVE THE CONTROL LEVER(S) IN A GENTLE, SLOW MOTION. NEVER PULL OR PUSH THE CONTROL LEVER(S) RAPIDLY, ESPECIALLY ON GRADES.

11. **BRAKING:** To brake mower, gently move the Control Lever(s) in the direction opposite to travel. If the parking brake is engaged with the Joystick Control Lever in the "UP" position or the Twin Sticks (if equipped) in the "IN" position the engine will stop.
12. **CUTTING HEIGHT ADJUSTMENT:** With the Cut Height Adjustment Lever latched into the top cut height latch. Insert Cut Height Stop Pin to desired cutting height. Pull Cut Height Adjustment Lever rearward and then to the left to clear top cut height latch. Lower Cut Height Adjustment Lever until it rests on Cut Height Stop Pin.
13. **ENGAGE MOWER BLADE CLUTCH:** Set the Blade Clutch Switch to the "ON" position. The engine will not start if the blade clutch is engaged. If the operator is not in the seat, the engine will stop if the clutch is engaged.



CAUTION



AVOID HILLS AND SLOPES. USE EXTREME CAUTION WHEN MOWING UP OR DOWN SLOPES. NEVER MOW ACROSS THE FACE OF A SLOPE. IF A SLOPE MUST BE ASCENDED, BACK UP THE SLOPE; DRIVE FORWARD WHEN DESCENDING.

14. **TO STOP:**
 - A. Move Joystick Control Lever to neutral position and then to the "DOWN" position.
 - A2. Move the Twinstick handles to the neutral position and then push both handles out as far as they will go.

B. Disengage the mower blade clutch by moving the clutch to the "OFF" position.

C. Set the parking brake.

D. Slow engine speed with throttle to slowest position.

E. Turn ignition key to "OFF" (left) position.

F. Remove the key and wait for all movement and all sound to cease before dismounting.



CAUTION



WHEN LEAVING THE MOWER UNATTENDED, ALWAYS REMOVE THE KEY AND SET THE PARKING BRAKE, EVEN IF JUST FOR A FEW MOMENTS. HELP PROTECT CHILDREN AND OTHER UNAUTHORIZED PERSONS FROM ACCIDENTS.

15. **TO FREE WHEEL MACHINE:** Unscrew the bypass valve (½ turn counter clockwise) found on the left rear of the right pump and the valve on the right front of the left pump. A bolt is inserted into the valve to be used as a handle.

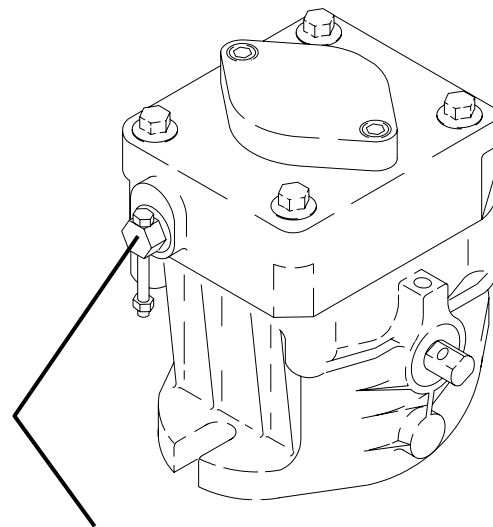

BYPASS VALVE

MOWING RECOMMENDATIONS

1. Keep mower blades sharp.
2. Make sure deck and discharge are clean.



3. When mowing tall grass, make two passes, mowing off 1/2 of the desired

cut on the first pass, and then the desired height the second pass. Check for hidden dangers first.

4. Go slowly for trimming.
5. Always cut grass with the engine at full throttle speed. This "ENGINE" speed allows the cutting blades to operate at optimum cutting speed. Control "GROUND" speed with the Control Lever(s).
6. Vary ground speed to suit conditions (i.e. go slower in tall thick grass, on hills, wet conditions, etc.)

SPECIFICATIONS		
TRACTORS		
Model	1706KAJ 1706KAT	1906KAJ 1906KAT
Engine	17 H.P. KAWASAKI	19 H.P. KAWASAKI
Hydrostatic Pumps Wheel Motors	(2) Parker-Ross	
Length	80.50"	
Height (to seat back) (to seat cushion)	44 1/2" 30"	
Width	48.50"	
Weight (tractor), approx.	720 lbs.	737lbs.
Fuel Tank	11 gallons	
Belt: Engine - Hydrostats	P/N D-3671	
Tires, Rear Front	23" x 9.50 X 12 13-5.00-6 (Ribbed)	

DECKS		
Model	4206M	4806M
Cutting Width	42"	48"
Overall Width (w/chute)	53"	58"
Weight (deck), approx.	190 lbs.	229 lbs.
Blades	(3) 15	(3) 17"
Cutting Height	1-1/2" to 5"	
Material Thickness	10 ga.	
Reinforcement Thickness	7 ga.	10 ga
Spindle Bearings	25 mm	

NOTE: Tractor should be matched to deck to insure sufficient power is available for the intended usage.

NOTE: All specifications subject to change without notice.

MAINTENANCE



CAUTION



**BEFORE PERFORMING ANY MAINTENANCE, TURN OFF ENGINE
REMOVE KEY AND DISCONNECT SPARK PLUGS. USE EXTREME CARE WHEN WORKING ON
MACHINERY. DO NOT WEAR WATCHES OR JEWELRY. DO NOT WEAR LOOSE FITTING
CLOTHES, AND OBSERVE ALL COMMON SAFETY PRACTICES WITH TOOLS.**

MAINTENANCE SCHEDULE

<i>SERVICE</i>	<i>WHEN</i>
Check crankcase oil level	before each use
Clean grass from Hydrostat Oil Cooler.....	before each use
Check air intake screen	after each use
Clean grass under deck	after each use
Check tire pressure	every 10 hours
Check battery fluid	every 10 hours
Sharpen mower blades	every 10 hours
Clean air filter pre-cleaner element	every 25 hours
Check Hydrostatic Transmission fluid	every 25 hours
Check drive belts	every 50 hours (20 hours break-in)
Service Air Cleaner Filter Element	every 100 hours
Change engine crankcase oil	100 hours
Oil filter	200 hours
Change Hydrostat oil and oil filter	every 500 hours (100 hours break-in)
Replace air filter element	annually or 500 hours
Check spark plugs	annually or 500 hours
Service battery	annually or 500 hours
.....	

Replace decals when illegible. Write factory for free replacement.

MAINTENANCE INSTRUCTIONS

1. ENGINE:

For complete maintenance and operating information for your engine, please refer to your engine operating and maintenance instructions furnished by the engine manufacturer and included in your **Country Clipper Zero Turning Radius Mower** information packet.

NOTE: Air intake screen must be kept clean. If plugged, engine may be seriously damaged by over heating.

2. BATTERY:

⚠ CAUTION ⚠

BATTERY ELECTROLYTE IS A POISONOUS AND CORROSIVE SULFURIC ACID SOLUTION. AVOID SPILLING ON SKIN, EYES, AND CLOTHING.

Keep the electrolyte level above the plates in each cell by adding distilled water as it becomes necessary. Add water just before operating the mower to mix the water with the solution. Be careful not to overfill the battery -- the electrolyte solution is corrosive and can cause damage to surrounding metal parts if it should spill. When taking the battery out of the mower for servicing, make sure to connect the cables to the battery exactly as they were prior to removal. Always disconnect the ground (-) wire first and always reconnect the ground (-) wire last.

Keep the battery clean. Remove the corrosion around the battery terminals by applying a solution of one part baking soda to four parts water. Coat all exposed terminal surfaces with a light layer of grease or petroleum jelly to prevent corrosion.

NOTE: At temperatures below 32 degrees F (0 degrees C) the full charge state must be maintained to prevent cell electrolyte from freezing and causing permanent battery damage.

3. TIRES:

Correct tire pressure is essential for efficient operation of the mower. Check tire pressure as requested in the maintenance schedule. Inflate tires to the pressures listed below:

Model	Front tires	Rear tires
All Models	12 psi	12 psi

Lug nuts should be checked regularly for tightness.

4. MOWER BLADES:

Check sharpness of mower blades after every 10 hours of operation. To sharpen blades proceed as follows:

⚠ CAUTION ⚠

STOP ENGINE, REMOVE IGNITION KEY AND SPARK PLUGS FOR SAFETY.

A. Remove bolt, lockwasher, and cup washer mounting blade on shaft. Remove blade.

B. Blades should be discarded when worn excessively.

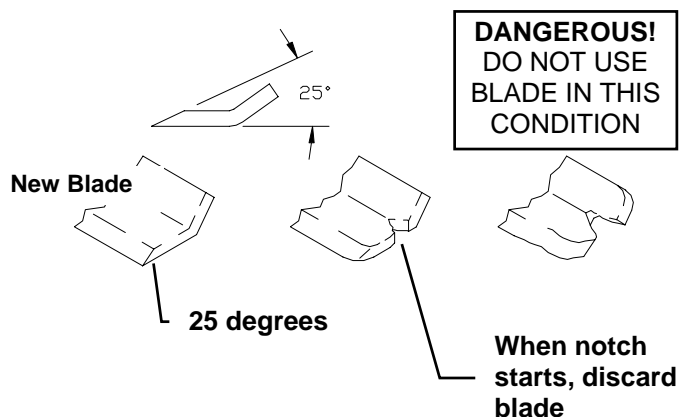

C. Sharpen blades with a hand file, electric grinder or blade sharpener. Wear gloves and eye protection when sharpening. Grind blade at original 25 degree bevel.

D. Check balance of blade by positioning the blade on a nail or blade balance pedestal. Grind the blade on the end that is heavier until both sides balance.

E. Install blade, cup washer, lockwasher, and bolt. Make sure to tighten bolt to 60 ft.lbs.

5. V-BELTS:

All belts should be checked every 50 hours. Replace any belts found to be in poor condition. All belts are equipped with spring loaded belt tighteners and do not require tightening adjustments.

6. LUBRICATION:

A. Engine: Follow engine manufacturer's recommendation.

B. Deck Spindles: Lubricate with 3 "shots" only, every 100 hours.

C. Hydrostatic Transmission & Filter: Follow instructions listed below.

Check the oil level in hydrostatic transmission oil reservoir after every 25 hours of usage. Clean the oil reservoir cap and the area around it prior to removal. Check the oil level on the dipstick. The proper oil level should register between the marked hole on the dipstick and the end of the dipstick. Replenish as needed with 20W-50 Motor Oil. **DO NOT OVER FILL.** When checking the oil level, be very careful to keep the reservoir clean

Change the oil in the reservoir and hydrostatic transmission filter after the first 100 hours of use, then every 500 hours after that. Remove the filter and be sure all oil has drained from the reservoir. Replace with new filter (P/N H-2026) and 20W-50 Motor Oil.

7. PARKING BRAKE ADJUSTMENT:

DIRT OR WATER IN OIL CAN RUIN THE HYDROSTATIC TRANSMISSIONS

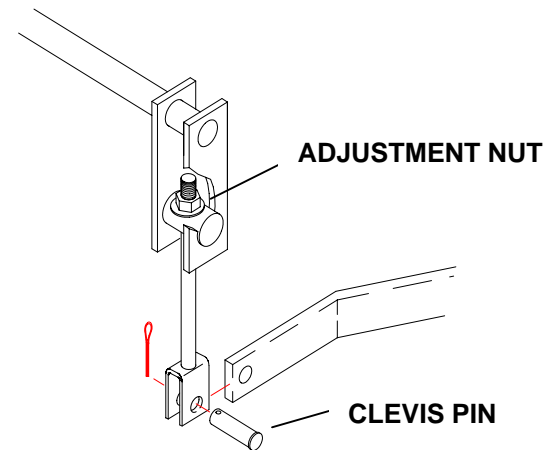
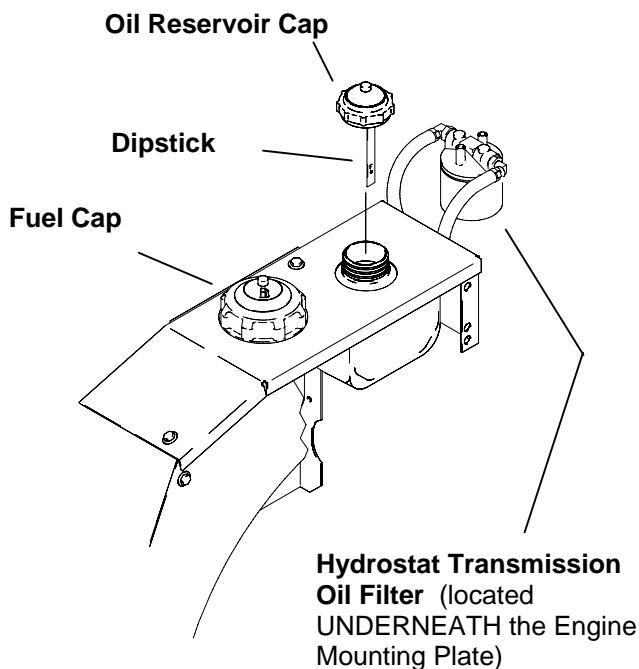

- A.** Remove the clevis pin from the left brake.
- B.** Tighten the adjustment nut on the right brake until it takes 28 pounds of pull to lock the brake handle over center.
- C.** Install the clevis pin back on the left brake.
- D.** Tighten the adjustment nut on the left brake until it takes 56 pounds to lock the brake handle over center, with both brakes connected.

TWINSTICK STEERING CONTROL ADJUSTMENT

8. To Adjust Neutral:

- a. Remove the fender skirts from each side of the machine.
- b. Block up the unit so that the Drive Wheels are off the ground.
- c. Start the engine and run at a fast idle with the Steering control levers in the "out" position.
- d. Loosen the locknuts tightened against the rod end ball joints in the Upper Linkage Assembly. (Note: One of these is a left-hand nut and will have to be turned backwards.)
- e. Adjust the Neutral Position by turning the rod in the upper linkage until the wheel stops turning.
- f. Retighten the nuts on the Upper Linkage Assembly and check to see that the drive wheel is still not turning.
- g. Repeat steps 1-6 for the other side.
- h. Shut off engine before removing the blocks.

9. To Adjust "IN" Position of the Steering Controls:

- a. Remove the 2 Front Bolts, Lockwashers, and Washers, which hold the Fender Cap.
- b. Pull the boot from the hole in the fender cap, exposing the cast iron lever.
- c. Using a 5/32" Allen Wrench, turn the setscrew to adjust the stop.
- d. Replace the Boot into the hole in the Fender Cap.
- e. Replace the 2 Front Bolts, Lockwashers, and Washers.

10. To Align Handles:

Sit on the seat and push the control levers full forward and full backward. If the ends do not match the handles may be adjusted as follows:

- a. Locate Setscrew stops in the Steering Control Lever Base, which stop the lever in each direction. (Note: The one at the rear is the stop for FWD and the one in the front is the stop for REV.)
- b. Adjust setscrew stops so that handles align when shifted full forward and full reverse.

11. Adjusting for Straight Forward Tracking:

In a large open area, actuate the control handles into the full forward position. If the mower veers in either direction left or right some adjustment is necessary.

- a. If the mower veers to the right, then the right hydrostat needs to be sped up. If the mower veers to the left, then the left hydrostat needs to be sped up.
- b. Stop the machine and shut off the engine.
- c. Slightly loosen the bolt at the lower end of the upper linkage assembly on the side that is slower. Using a 1/8" allen wrench turn the setscrew 1/4 turn in. It may take several test drives to get the mower to track straight forward.
- d. Once the tracking is to the operators liking, completely tighten the bolt on the control linkage assembly that was loosened earlier.
- e. Recheck to make sure neutral adjust has not been effected, see procedure A.

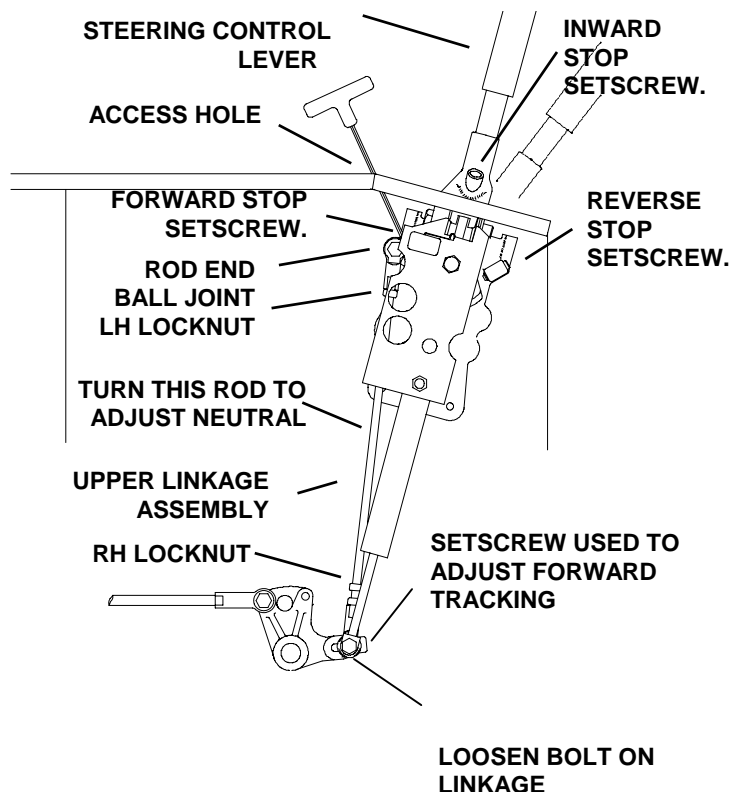

12. JOYSTICK CONTROL LEVER NEUTRAL ADJUSTMENT:

With the engine running, if the machine travels in either direction when the Joystick Control Lever is in the neutral "DOWN" position, stop the engine, elevate the rear wheels clear of the ground and adjust as follows:

- A. Remove the right hand fender skirt exposing the Joystick Control Lever Assembly.
- B. Start the engine.
- C. Run the engine at fast idle with Joystick Control Lever in the "DOWN" position.
- D. Loosen the locknuts tightened against the rod end ball joints on the Upper Linkage Assembly that corresponds to the wheel that is turning. Note: One of these is a left-hand nut and will have to be turned backwards.
- E. Adjust the Neutral Position by turning the rod in the upper linkage until the wheel stops turning.
- F. Re-tighten the locknuts on upper linkage assembly and check to make sure the drive wheel is still not turning.
- G. Repeat steps B through F for other side.
- H. Shut off the engine before removing from blocks. Replace fender skirt.

13. JOYSTICK ADJUSTMENT: CONTROL LEVER DETENT

If the Joystick Control Lever does not lock in the "UP" position, turn the detent adjustment screw clockwise until a desirable locking action is obtained. If the Joystick control Lever is hard to slide up and down, turn the detent adjustment screw counter-clockwise until a desirable sliding action is obtained.

14. JOYSTICK CONTROL LEVER SENSITIVITY ADJUSTMENT

To change the sideways turning response Adjust as follows:

- A. Remove the right hand fender skirt exposing the Joystick Control Lever assembly.
- B. Remove the cross bolt, nut, and spacers
- C. Reassemble the spacers as desired. (2) Spacers between the rod end ball joints and the joystick pivot shaft will quicken the side to side response, (1) spacer slows the response.

NOTE: It is important that there is at least one spacer on each side of the rod end ball joints to prevent damage. Also the small diameter of the spacer must point towards the rod end ball joint.

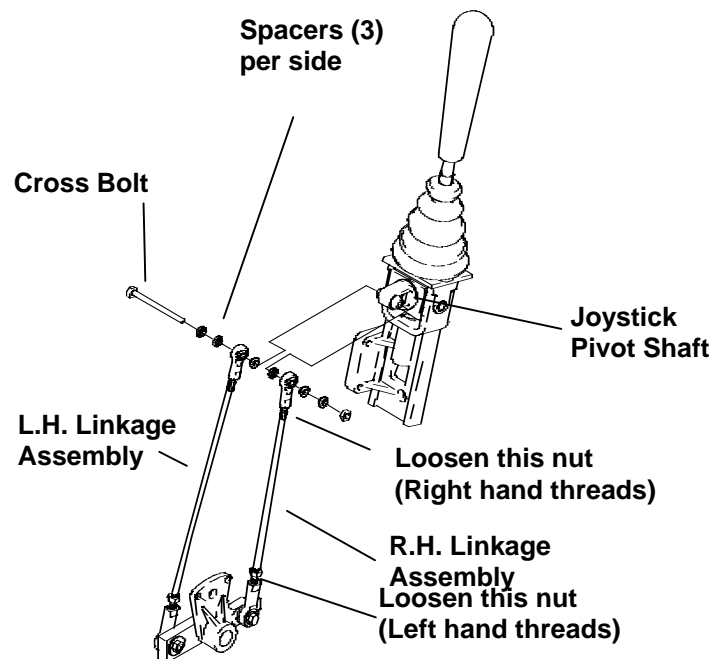

15. ADJUSTING FOR STRAIGHT FORWARD TRACKING:

In a large open area, actuate the Joystick Control lever into the full forward position. If the mower veers in either direction left or right some adjustment is necessary.

- A. If the mower veers to the right, then the right hydrostat needs to be sped up. If the mower veers to the left, then the left hydrostat needs to be sped up.

- B. Stop the machine and shut of the engine.
- C. Slightly loosen the bolt at the lower end of the upper linkage assembly on the side that is slower. Using a 1/8" allen wrench turn the setscrew 1/4 turn in. It may take several test drives to get the mower to track straight forward.
- D. Once the tracking is to the operators liking, completely tighten the bolt on the control linkage assembly that was loosened earlier.
- E. Recheck to make sure neutral adjustment has not been effected.

See picture at right:

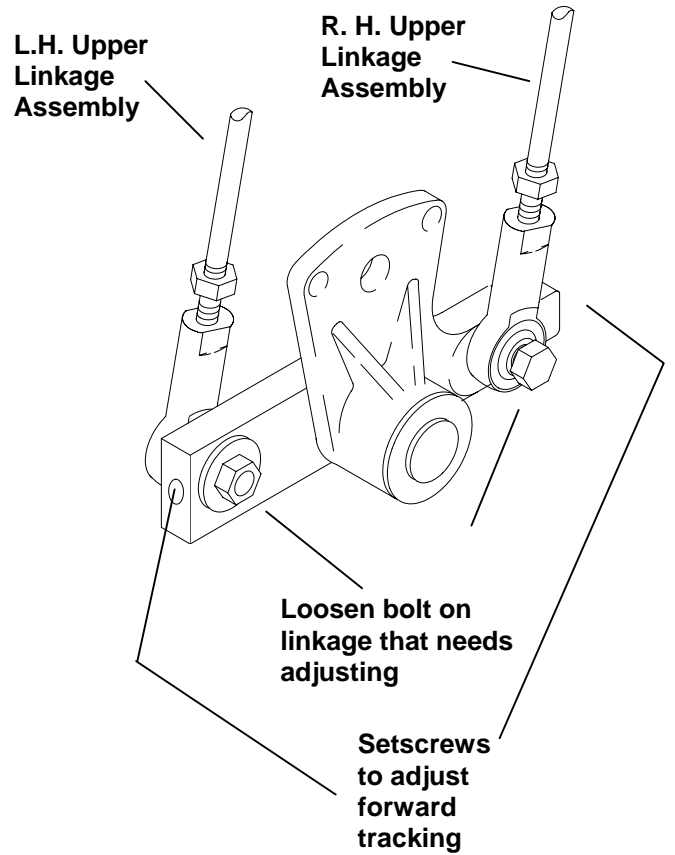

**DRIVE BELT CONFIGURATION
VIEWED FROM FLOOR LOOKING UP**

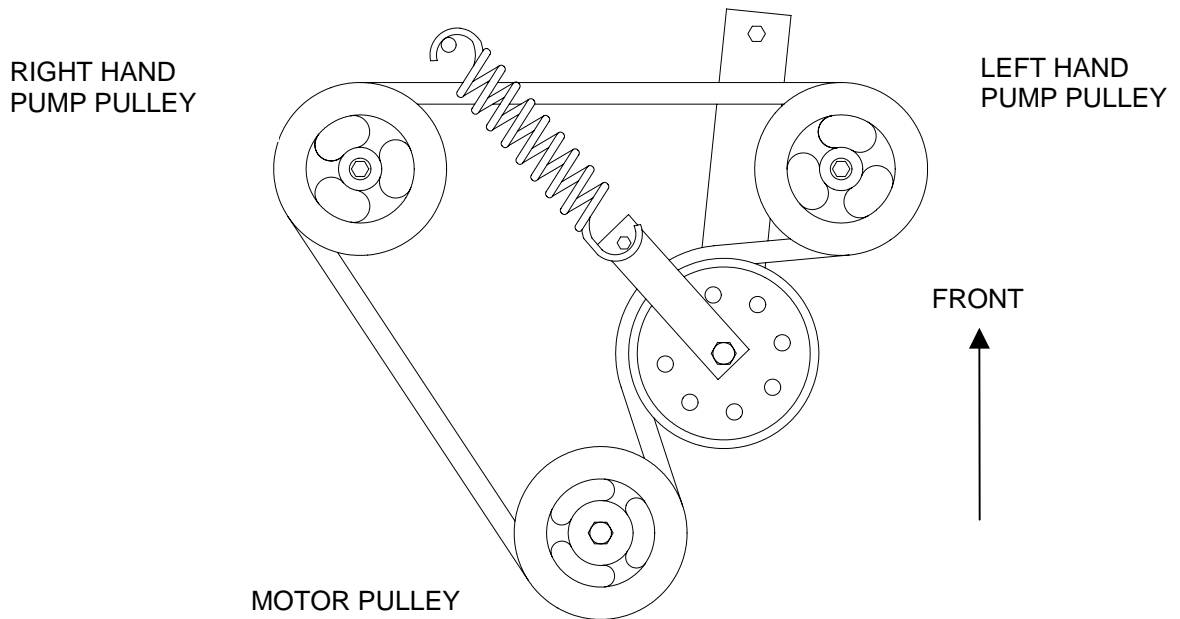

PROCEDURE FOR RAISING AND LOWERING THE DECK FOR SERVICING

14. RAISING THE DECK:

- A. Remove cut height adjustment pin and completely lower the cut height adjustment lever. Re-insert the cut height adjustment pin into the 3-1/2" cut height position (this will lock the cut height adjustment lever into the lowest position).
- B. Flip up the foot deck to allow access to the engine to deck drive belt. Roll the engine to deck drive belt off the center spindle. Hook the engine to deck drive belt onto the bolt protruding out of the top of the foot deck support angle.
- C. Lift the rear corner of the deck and disconnect the rear deck mount latch. Repeat for the other side.
- D. Position the front caster wheels so they are away from the deck (such as the tractor would be traveling in reverse).
- E. Lift the nose of the deck until the deck is standing vertical (lifting can be made

easier if someone stands on the rear bumper of the tractor). **IMPORTANT NOTE: MAKE SURE THAT THE DECK IS LIFTED FAR ENOUGH FOR THE DECK LATCH TO FULLY ENGAGE THE LOCKING PIN** (located on the left side of the deck mounting suspension). This will prevent the deck from falling down when servicing the underside of the mower deck.

15. LOWERING THE DECK:

- A. While lifting the nose of the deck, disengage the deck latch from the locking pin. Push the bottom of the deck towards the rear of the tractor while holding the deck latch so that it clears the locking pin. Lower the deck until it rests on the ground.
- B. Lift the rear corner of the deck and re-connect the rear deck mount latch. Repeat for the other side.
- C. Roll the engine to deck drive belt back onto the center spindle. Insure that the engine to deck drive belt is installed onto all of the pulleys and idlers in the drive train.
- D. Lower the foot deck down into the operation position.

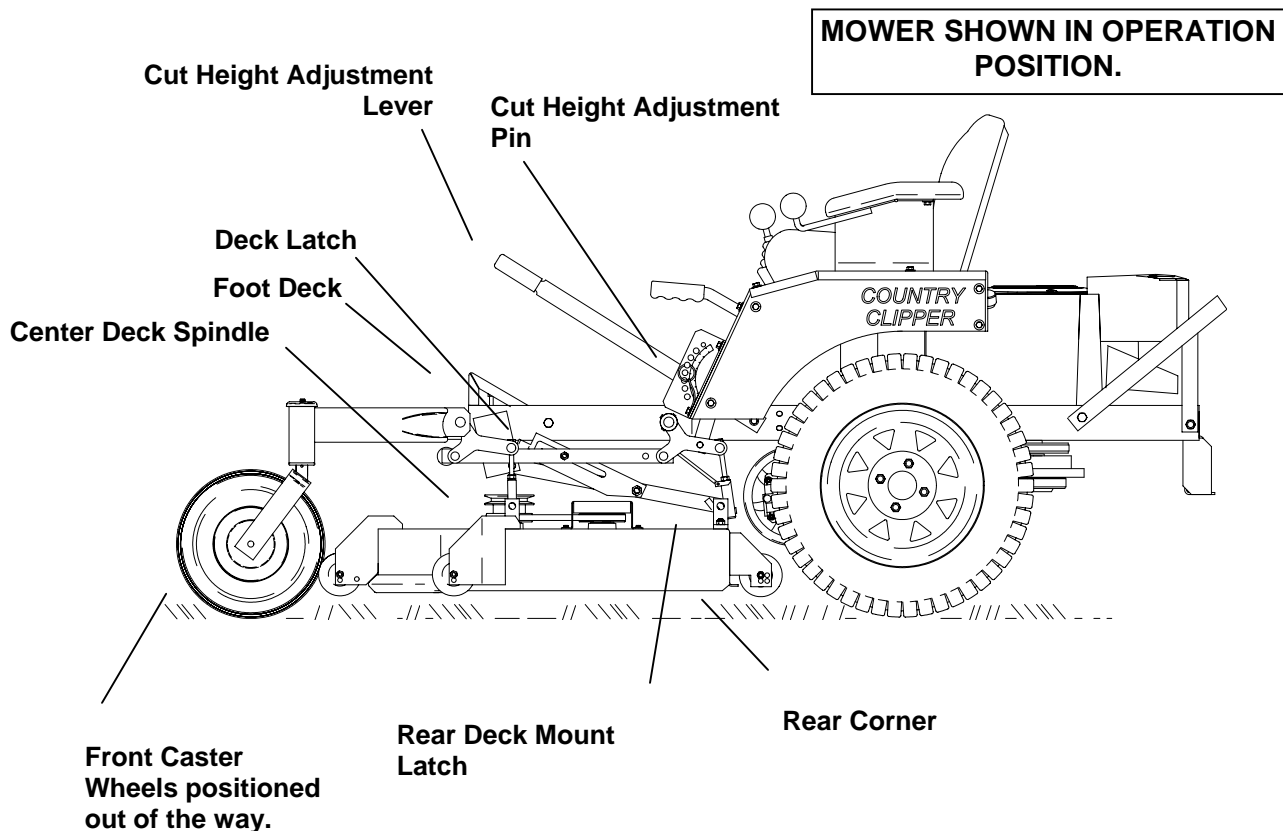

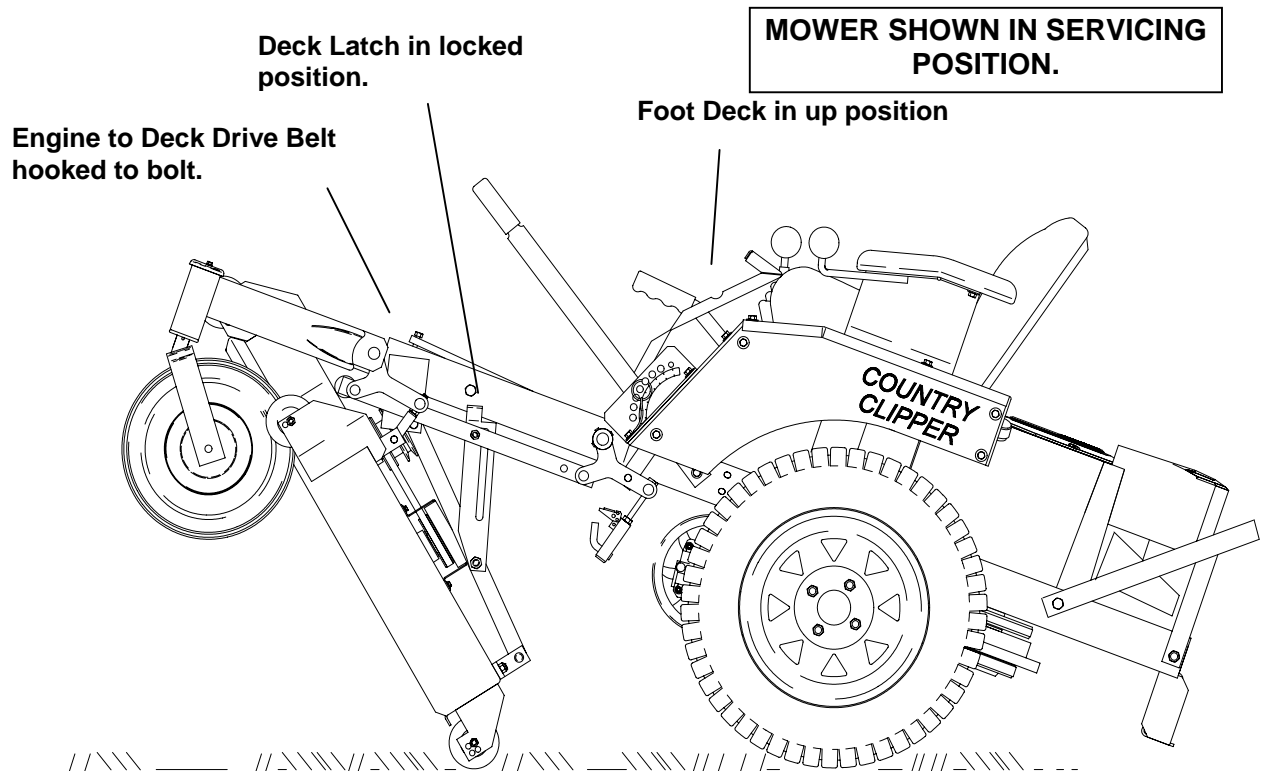

16. LEVELING THE DECK:

A. Set the tire pressure on all four tires

B. Move the tractor to a hard, level surface (i.e. concrete or blacktop). Place a 2 x 4 board under all four corners of the deck shell, just inside of the anti-scalping wheels. Lower the deck down onto the boards. The deck must rest on the boards, NOT the anti-scalping wheels. Adjust the deck hangers longer or shorter until the deck "just" comes off of the boards. Remove the boards and verify that the deck is hanging on all four deck hangers; re-adjust if necessary. Either lengthen both front deck leveling screws three full turns or shorten both rear deck leveling screws three full turns. Lock the jam nuts on the deck hangers. (NOTE: the two rear deck hangers will be easier to adjust if the fender skirts are removed).

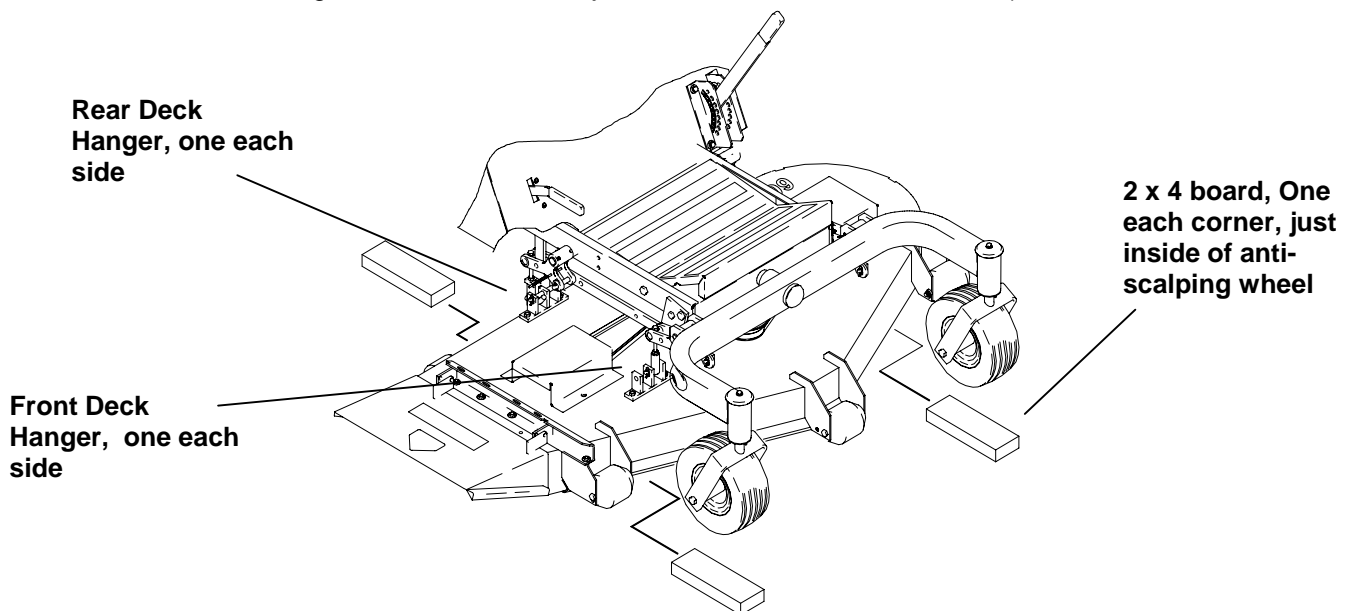

TROUBLE SHOOTING CHECK LIST

1. ENGINE WON'T TURN OVER:
 - Mower blades engaged ----- disengage blades
 - Drive not in neutral --- **moves Joystick Control Lever to neutral "DOWN" position**
move Twinstick Control Levers to neutral "OUT" position
 - Blown fuse ----- replace fuse
 - Dead battery ----- charge or replace
 - Solenoid ----- consult dealer
 - Ignition switch ----- consult dealer
 - Starter ----- consult dealer

2. ENGINE WILL TURN OVER BUT WON'T START:
 - No gas ----- refuel
clean or replace fuel filters
 - Over or under choked ----- adjust choke
 - Spark plug not firing ----- check spark plug
condition and reset gap*
 - Carburetor maladjustment ----- reset carburetor adjustment*
 - Ignition switch ----- consult dealer

3. HARD TO START ENGINE:
 - Fuel line clogged ----- clean fuel line and check fuel filter
 - Faulty fuel pumps ----- consult dealer
 - Spark plug wire loose or grounded ----- check spark plug wires
 - Spark plug(s) faulty or improperly gapped ----- check spark plug
condition and reset gap*
 - Electronic ignition defective ----- consult dealer
 - Dirty or maladjusted carburetor ----- readjust carburetor*
consult dealer for carburetor service

4. ENGINE STARTS BUT CUTS OUT:
 - Water in gasoline ----- drain old gasoline and replace with new gasoline
clean carburetor bowl
 - Clogged fuel line ----- check fuel filter
clean fuel line
 - Vent in fuel cap plugged ----- check vent
 - Faulty fuel pump ----- consult dealer
 - Maladjusted carburetor ----- readjust carburetor*
 - Engine dies when: **Joystick Control Lever is pulled "UP"** ----- parking brake set
Twinstick Control levers are pulled "IN" ----- release brake

5. ENGINE KNOCKS:
 - Low oil level ----- check and add oil
 - Ignition timing off ----- consult dealer
 - fuel octane too low ----- drain and replace with
higher octane gasoline
 - Over heated engine ----- shut off engine and allow to cool

* See engine manual for engine adjustments.

- 6. ENGINE SOMETIMES SKIPS AT HIGHER SPEEDS:**

 - Incorrect Ignition Timing ----- consult dealer
 - Carburetor maladjusted ----- readjust carburetor
 - Faulty spark plugs ----- check spark plug
condition and reset gap*
 - Bouncing off seat safety switch ----- slow down on rough terrain

- 7. ENGINE OVER HEATED:**

 - Air intake screen or fins clogged ----- clean intake screen and fins
 - Fuel mixture too lean ----- readjust carburetor*
 - Oil level too low or too high ----- adjust oil level
 - Improper ignition timing ----- consult dealer
 - Running engine too slow ----- run engine faster

(NOTE: Always mow at full throttle setting.)

- 8. ENGINE IDLES POORLY:**

 - Carburetor maladjustment ----- readjust carburetor
 - Improper spark plug gap ----- check and re-gap plug*

- 9. ENGINE BACKFIRES:**

 - Carburetor maladjustment ----- readjust carburetor*

- 10. ENGINE RUNS BUT MOWER WON'T MOVE FORWARD:**

 - Drive belt broken or slipping ----- replace drive belt
 - Transmission shift arm disconnected ----- reconnect
 - Transmission oil low ----- add oil
 - Transmission in free wheel position ----- tighten bypass valves (see pg. 8)
 - Hydrostat oil filter plugged ----- replace filter
 - Bad transmission ----- consult dealer

- 11. MOWER LOSES POWER OR TRANSMISSIONS OVER HEATS:**

 - Hydrostat transmission oil too low or too high ----- add oil
OR drain oil as needed
 - Transmission damage ----- consult dealer
 - Transmission blowing oil out cap ----- overfilled or water
contaminated

- 12. ENGINE STALLS WHEN BLADES ARE ENGAGED:**

 - Operator not on seat ----- sit on seat
 - Faulty interlock system ----- consult dealer
 - Bad blade spindle bearing ----- consult dealer
 - Deck drive belt not properly routed ----- reroute
 - Blades blocked by foreign material ----- clean under deck

* See engine manual for engine adjustments.

WIRING SCHEMATIC: FOR JOYSTICK MODEL

Note: All wire connectors shown at wire side.

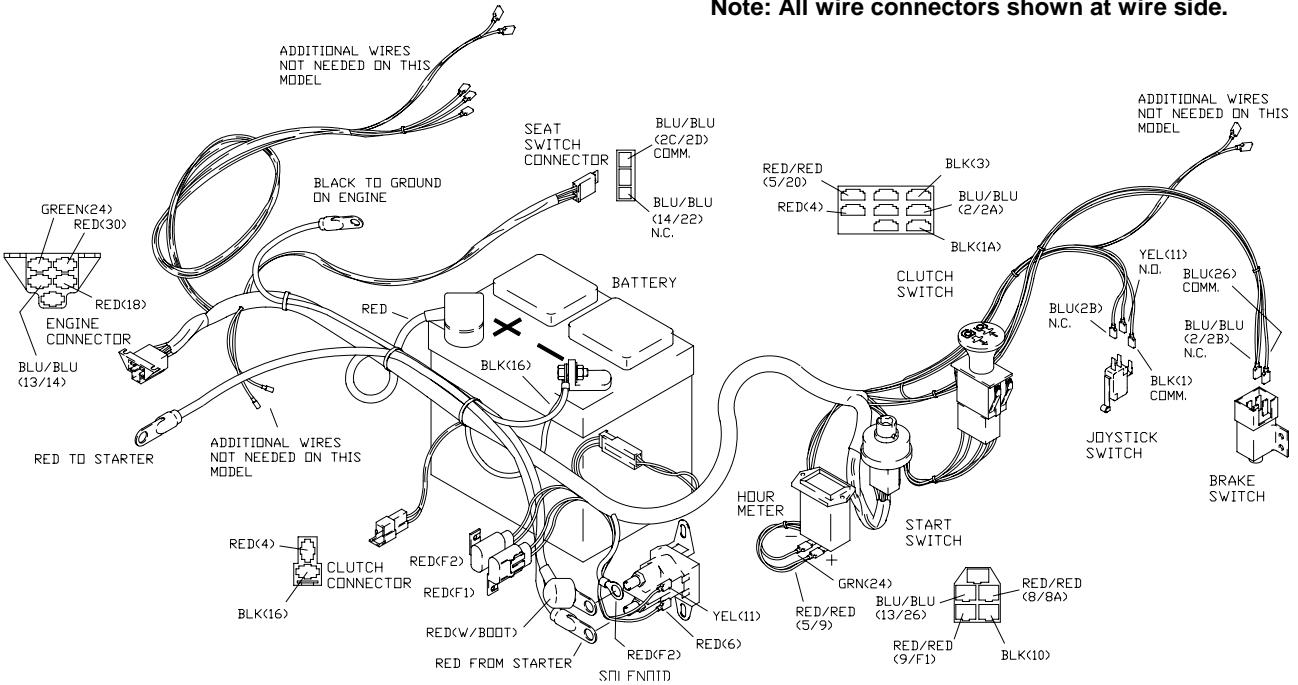

Black wires = Ground
 Red wires = Power
 Blue wires = Kill Circuit
 Yellow wires = Start Circuit
 Green wires = Signal Circuit

START SWITCH POSITION	CIRCUIT "MAKE"
OFF	G+M
ON	B+L
START	B+L+S

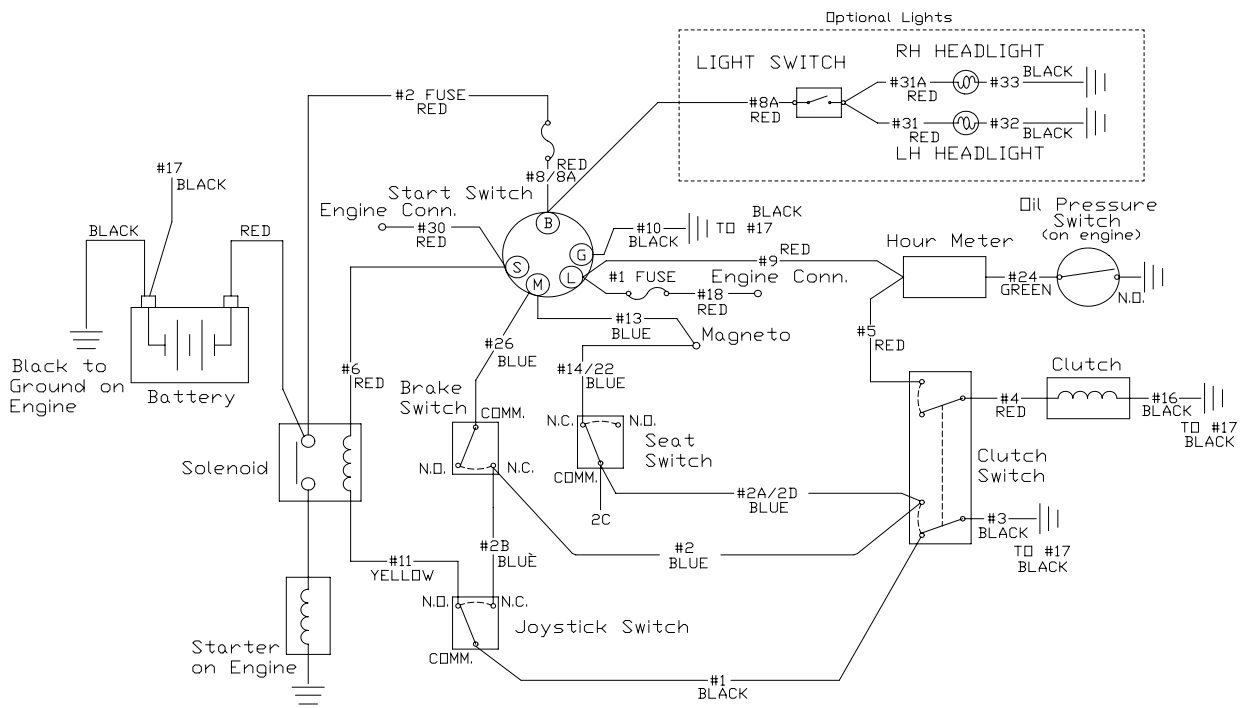

WIRING SCHEMATIC: FOR TWINSTICK MODEL

NOTE: ALL WIRE CONNECTORS SHOWN AT WIRE SIDE

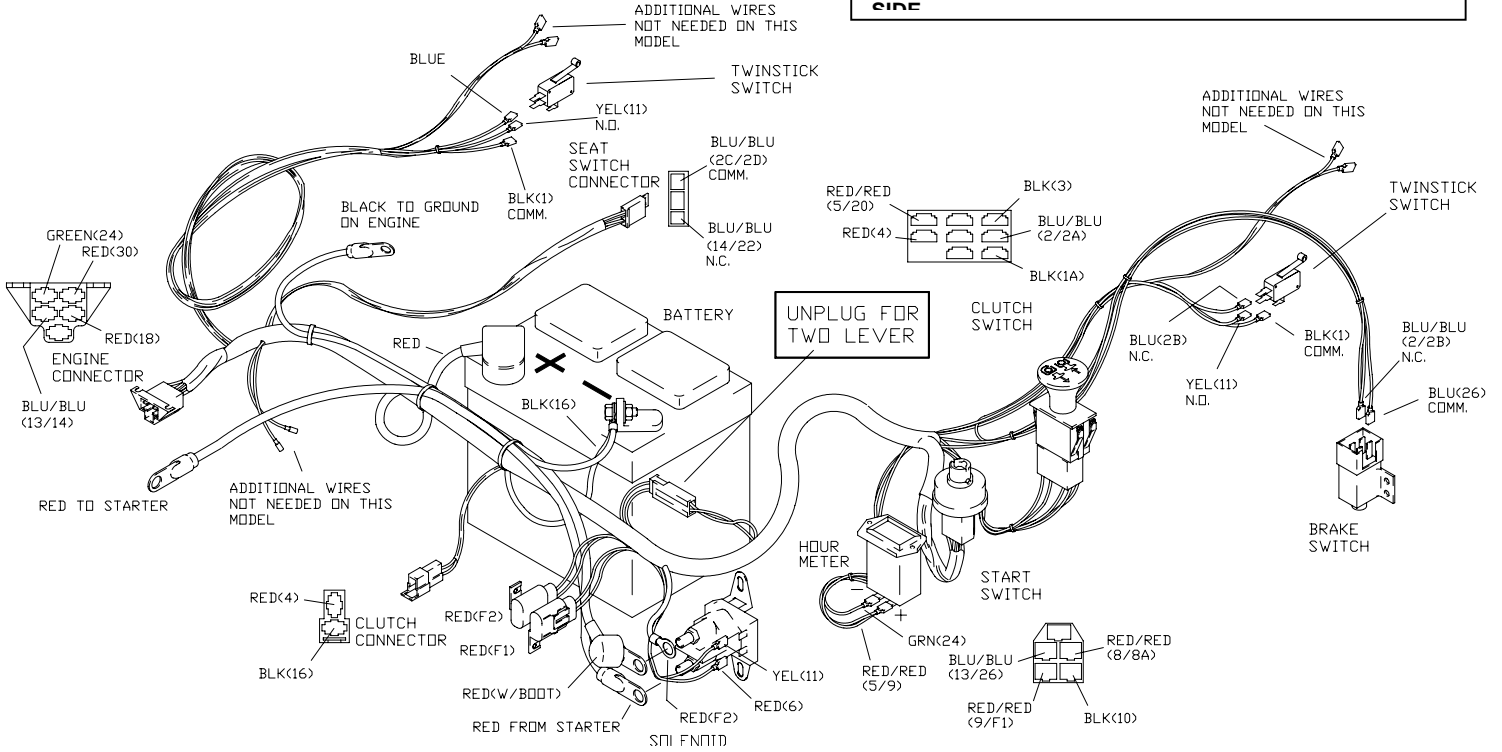

Black wires = Ground
 Red wires = Power
 Blue wires = Kill Circuit
 Yellow wires = Start Circuit
 Green wires = Signal Circuit

START SWITCH POSITION	CIRCUIT "MAKE"
OFF	G+M
ON	B+L
START	B+L+S

