

# Safety Instructions & Operators Manual



Zero Turn Radius Mower



Congratulations for buying a **Country Clipper** product. Your **Country Clipper** Zero Turning Radius Riding Mower was designed and built to provide long and trouble free service. Keep in mind that it, like any other mechanical device, can be potentially dangerous if used improperly, and hazard control and accident prevention are dependent upon the awareness, concern, prudence, and proper training of personnel involved in the operation, transport, maintenance, and storage of the equipment. Study this manual and pay special attention to the important Safety Precautions on pages 4-6. Following these instructions will help you continue to enjoy the trouble-free performance expected of your **Country Clipper** product.

# TABLE OF CONTENTS

<b><i>SAFETY</i></b> .....	<b>3</b>
ACCIDENT PATTERNS TO AVOID .....	3
SAFETY INSTRUCTIONS AND RECOMMENDATIONS .....	3
SAFETY INTERLOCK SYSTEM .....	5
<b><i>START UP AND OPERATION</i></b> .....	<b>6</b>
CHECKLIST BEFORE OPERATION .....	6
CONTROL LOCATIONS .....	6
OPERATION .....	7
MOWING RECOMMENDATIONS .....	9
<b><i>MAINTENANCE</i></b> .....	<b>10</b>
MAINTENANCE SCHEDULE .....	10
MAINTENANCE INSTRUCTIONS.....	11
BELT ROUTING.....	14
PROCEDURE FOR RAISING AND LOWERING THE DECK FOR SERVICING .....	15
<b><i>TROUBLE SHOOTING CHECKLIST</i></b> .....	<b>17</b>
<b><i>WIRING SCHEMATIC FOR SR100 AND OLDER MODELS</i></b> .....	<b>19</b>
<b><i>WIRING SCHEMATIC FOR SR105 &amp; SR110 MODELS</i></b> .....	<b>20</b>
<b><i>NOTES AND SERVICE RECORDS</i></b> .....	<b>1</b>

## SAFETY

### ACCIDENT PATTERNS TO AVOID

- I. **CONTACT WITH THE ROTATING BLADE** -- This accident usually happens when the operator is clearing the discharge chute of grass, (especially when the grass is wet), or when the operator adjusts the machine without turning it off and waiting for the blades to completely stop.
- II. **PROPELLED OBJECTS** -- Sticks, rocks, wires, and other objects can be propelled out through the discharge chute or from under the mower housing. Bystanders are particularly vulnerable.
- III. **GRASS CATCHER OR GUARD** -- The mower shall not be operated without either the entire grass catcher or guard in place.
- IV. **OVERTURNING** -- This happens when riding mowers are used on steep slopes, embankments or hills. The operator in these cases can come in contact with the blades or sustain injuries during a fall.
- V. **MOWER RUNNING OVER THE VICTIM** -- This usually happens when a riding mower is driven in reverse. The accident victims are most often young children whom, unseen by the operator of the mower, were in the area being mowed.

AT **COUNTRY CLIPPER**, WE SHARE YOUR DESIRE TO PROTECT YOURSELF, YOUR FAMILY, YOUR FRIENDS AND YOUR NEIGHBORS FROM ACCIDENTAL INJURY. OBSERVING AND ENFORCING THE FOLLOWING GUIDELINES WILL HELP TO INSURE THE SAFETY OF EVERYONE.

**PLEASE BE CAREFUL!**

### SAFETY INSTRUCTIONS AND RECOMMENDATIONS

1. **PEOPLE WHO OPERATE, SERVICE, OR ARE OTHERWISE ASSOCIATED** with the **Country Clipper** Zero Turning Radius Mower should be trained in its proper use and warned of its dangers. Before operating, adjusting, or servicing the **Country Clipper** Zero Turning Radius Mower they should read and understand this entire manual and the engine owner's manual.
2. **AVOID CONTACT WITH MOVING PARTS.** Keep hands and feet from under mowing deck and away from blades at all times. Turn engine (motor) off if you must unclog the chute.
3. **AVOID HILLS AND SLOPES.** Use extreme caution when mowing up or down slopes. NEVER mow across the face of a slope. If a slope must be ascended, back up the slope; drive forward when descending. Reduce speed and use caution to start, stop and maneuver. To prevent loss of control on a slope avoid sharp turns, sudden changes in direction, and sudden stops and starts.
4. **DISENGAGE POWER TO MOWER BEFORE BACKING UP.** Do not mow in reverse unless ABSOLUTELY necessary and then only after turning around and observing the entire area behind the mower. Go slowly. Most "running over victim" accidents occur in reverse.
5. **BEGINNING OPERATORS SHOULD LEARN HOW TO STEER** the **Country Clipper** Zero Turning Radius Mower before attempting to mow. Start with slow engine speed and drive without the blades engaged in an open area until comfortable with the machine.
6. **KNOW HOW TO STOP QUICKLY.** Know the location and operation of every control, especially how to brake and how to disengage the mower blades.

7. **DO NOT MOVE JOYSTICK CONTROL LEVER** from forward position to reverse position rapidly. The speed and/or direction of travel is affected instantly by movement of the Joystick Control Lever.
8. **DO NOT ALLOW CHILDREN TO OPERATE MOWER.** Do not allow others who have not had instruction to operate mower.
9. **ALWAYS TURN ENGINE OFF AND REMOVE KEY** before leaving the mower to prevent children and inexperienced operators from starting the engine. Never leave the mower unattended with engine running. Always wait for all moving parts and all sounds to stop before leaving operator's seat.
10. **WEAR STURDY, ROUGH-SOLED WORK SHOES AND CLOSE-FITTING SLACKS AND SHIRTS.** Never operate mower in bare feet, sandals or sneakers.
11. **NEVER CARRY PASSENGERS.**
12. **KNOW THE AREA YOU ARE TO MOW.** Watch for hidden danger such as rocks, roots, sticks, holes, bumps, and drop-offs, etc. Before mowing, pick up all debris in area to be mowed. Sharp and hard objects can be propelled at a high speed and can act like shrapnel. Walk through tall grass BEFORE MOWING to make sure there are no hidden dangers. Mow higher than desired in tall grass to expose any hidden objects and/or obstacles, clean the area, and then mow to the desired height.
13. **NEVER REFUEL A MOWER INDOORS.** Allow the engine time to cool before refueling. Unseen vapors may be ignited by a spark. Always clean up spilled gasoline. Never run the engine indoors in a garage or any other closed building. Allow engine to cool before storing in any enclosure. The engine exhaust and gasoline fumes are dangerous.
14. **NEVER REMOVE THE FUEL CAP** or add gasoline to a running or hot engine that has not been allowed to cool for several minutes after running. Always make sure the gas cap is in place.
15. **DO NOT SMOKE AROUND THE MOWER** or the gasoline storage container. Gasoline fumes can easily ignite.
16. **KEEP GASOLINE IN A WELL-VENTILATED AREA** away from your living quarters and in tightly-capped safety cans. Never store mower with gasoline in the tank inside a building where fumes may reach open flame or spark.
17. **DISENGAGE BLADES, STOP ENGINE AND REMOVE IGNITION KEY** before any servicing. Be sure all moving parts and all sounds have stopped. Let engine cool and disconnect the spark plugs so the engine cannot start by accident. A SLIGHT ROTATION OF THE BLADES COULD START THE ENGINE.
18. **KEEP ALL NUTS, BOLTS, AND SCREWS TIGHT** to be sure equipment is in safe working condition, especially blade mounting bolts.
19. **VEHICLE SHOULD BE STOPPED AND INSPECTED FOR DAMAGE** after striking a foreign object and the damage should be repaired before restarting and operating the equipment. Stop immediately and check for damage or loose parts if mower should start vibrating.
20. **DISENGAGE BLADES BEFORE DRIVING ACROSS WALKS** or projecting objects.
21. **KEEP SAFETY DEVICES AND GUARDS IN PLACE.** If any of the safety switches become inoperable, have them repaired immediately.
22. **DO NOT STEP OR STAND ON THE MOWER HOUSING.** Step or stand only on the foot deck.
23. **WATCH OUT FOR TRAFFIC** near roadways and when crossing roads.
24. **DO NOT USE MOWER WHEN GRASS IS WET OR SLIPPERY.**
25. **MOW ONLY DURING DAYLIGHT.**

- 26. **THIS MACHINE IS NOT MEANT FOR HIGHWAY OR STREET USE.** It is not a recreational vehicle and it should not be operated as such.
- 27. **ALWAYS DISENGAGE THE MOWER BLADE CLUTCH** when transporting.
- 28. **KEEP ALL SAFETY LABELS IN LEGIBLE CONDITION.** Remove grease, dirt, grass, etc. that may cover safety labels. Replace any safety label that is missing or damaged.
- 29. **WEAR PERSONAL PROTECTIVE EQUIPMENT.** Eye, ear, feet and head protection is recommended.
- 30. **ONLY USE COUNTRY CLIPPER APPROVED ACCESSORIES.**
- 31. **DO NOT CHANGE THE ENGINE GOVERNOR SETTING** or over-rev. the engine.
- 32. **BEWARE OF MOWER DISCHARGE DIRECTION** and do not point it at anyone.
- 33. **DO NOT OPERATE THE MOWER UNDER THE INFLUENCE OF ALCOHOL OR DRUGS.**
- 34. **USE CARE WHEN LOADING OR UNLOADING MACHINE INTO A TRAILER OR TRUCK.**
- 35. **USE CARE WHEN APPROACHING BLIND CORNERS,** shrubs, trees, or other objects that may obscure vision.
- 36. **CLEAN ALL GRASS AND DEBRIS FROM MACHINE TO PREVENT FIRES.** Remove spilled oil or gasoline.
- 37. **KEEP HANDS AND FEET AWAY FROM MOVING PARTS.** If possible do not make adjustments with the engine running.
- 38. **CAREFULLY RELEASE PRESSURE FROM COMPONENTS WITH STORED ENERGY.**
- 39. **NEVER MOW WHEN OTHER PEOPLE OR PETS ARE IN THE AREA.**

- 40. **USE CARE WHEN REPLACING BLADES.** Wrap the blade(s) or wear gloves, and use caution when servicing them. Only replace blade(s). Never straighten or weld blade(s).
- 41. **USE JACKSTANDS TO SUPPORT COMPONENTS** when required.

## SAFETY INTERLOCK SYSTEM

Your *Country Clipper* Zero Turning Radius Mower is equipped with switches interlocked for your safety.

- 1. The mower blades must be disengaged before engine will start.
- 2. The Joystick Control Lever must be in the neutral “**DOWN**” position before the engine will start.
- 3. The engine will stop if the mower blade clutch is engaged when the operator leaves the driver’s seat.
- 4. The engine will stop if the Joystick Control Lever is not in the neutral “**DOWN**” position when the operator leaves the driver’s seat.
- 5. The engine will stop if the brake is “**SET**” and the Joystick Control Lever is moved to the “**UP**” position.
- 6. The engine will stop if the brake is “**SET**” and the mower blade clutch is engaged.

**DO NOT OPERATE MOWER IF SAFETY SWITCHES AND GUARDS ARE NOT OPERATING PROPERLY**

# START UP AND OPERATION

## CHECKLIST BEFORE OPERATION

1. Make sure fuel tank is full. Use regular unleaded gasoline (see engine owner's manual for more details).

**! WARNING !**

**HANDLE GASOLINE WITH CARE -- IT IS HIGHLY FLAMMABLE. DO NOT SMOKE. ENGINE SHOULD BE OFF AND COOL. USE APPROVED GAS CONTAINER. NEVER FILL TANK INDOORS. WIPE UP ANY SPILLS. REPLACE CAP TIGHTLY.**

2. Make sure dirt and foreign matter are kept out of gas tank. Use a clean funnel and gas can.
3. Do not mix oil with gasoline.
4. Do not use white, high test or premium gasoline. Do not use de-icers, carburetor cleaners, or other such additives.
5. Check the crankcase oil level. Make sure the engine is off. The mower should be parked on a level area. Do not overfill. (See your engine manual for more detailed instruction.)

6. Check battery fluid level.
7. Inspect V-belts.
8. Check tire pressure:

Model	Front tires	Rear tires
All Models	12 psi	12 psi

9. Make sure underside of mower deck is free of grass.
10. Make sure mower blades are sharp and secured tightly.
11. Clean the air intake screen on the engine if necessary.
12. Perform any other maintenance as it becomes necessary. (See the "Maintenance" section of this manual.)

**IMPORTANT:** Before cutting grass, clutch must be broken-in as follows: With engine at full RPM engage deck until blades come to full speed and then disengage until blades come to a complete stop. Repeat 10 times to "break-in" the clutch properly.

## CONTROL LOCATIONS

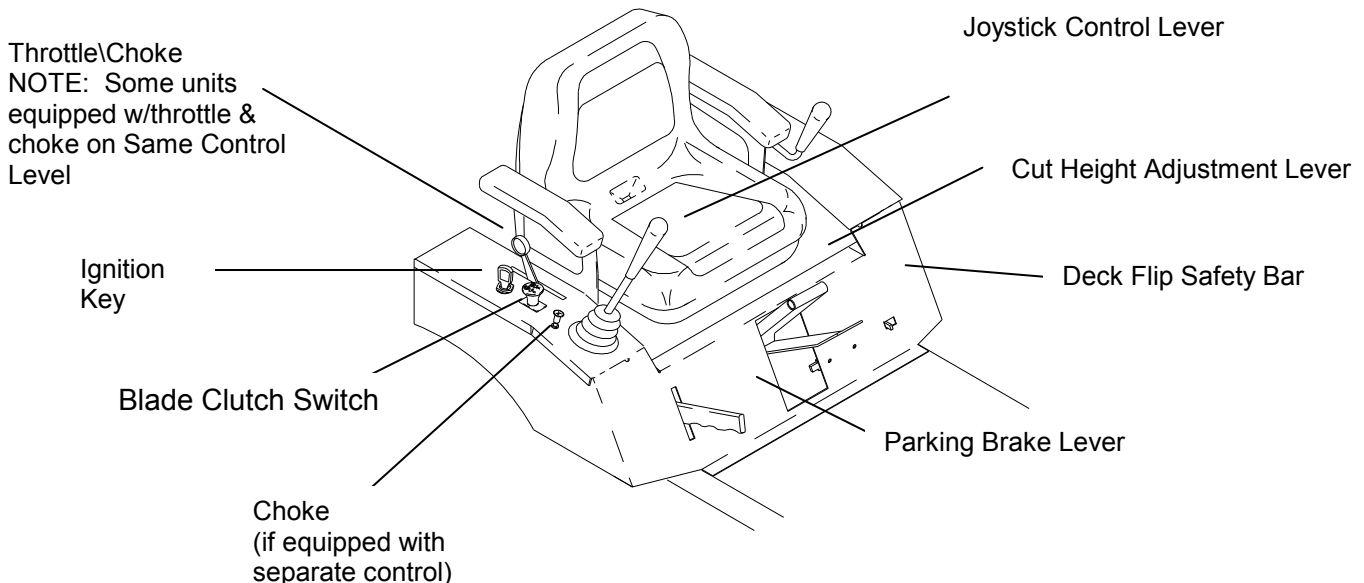



## **WARNING**



**AVOID INHALING EXHAUST FUMES -- CARBON MONOXIDE GAS IS COLORLESS AND ODORLESS, AND CAN CAUSE UNCONSCIOUSNESS, AND IS POTENTIALLY LETHAL. DO NOT RUN LAWN MOWER IN GARAGE OR OTHER CONFINED AREA.**

### **OPERATION**

1. MOVE JOYSTICK CONTROL LEVER TO neutral "DOWN" position.
2. SET PARKING BRAKE. Pull up to set.
3. DISENGAGE MOWER BLADE CLUTCH by moving clutch switch to "OFF" position.
4. TO START:
  - A. On 17 HP engine move Throttle/Choke To full choke position for cold starts. For warm starts place Throttle/Choke Control to ½ position.
  - B. On 16 HP engine pull Choke Control to full up position for cold starts.
5. TURN IGNITION KEY to "START" position and release to "RUN" as soon as engine starts. NOTE: Prolonged cranking will damage starter motor and shorten the battery life
6. ADJUST ENGINE THROTTLE AND CHOKE for desired engine smoothness and speed. NOTE: When mowing, always run engine at full throttle.
7. RELEASE PARKING BRAKE. Push brake lever down to release.

**IMPORTANT:** Until the operator is familiar with the **Country Clipper** Zero Turning Radius Mower, he/she should follow these recommendations: Disengage the mower blades. Go very slowly until thoroughly familiar with the machine. Keep away from fences, buildings, and other obstructions. Move the Joystick Control Lever smoothly and slowly. Practice until operation is smooth and efficient.

8. TO DRIVE
  - A. Move the Joystick Control Lever to the "UP" position.
  - B. Move the Joystick Control Lever forward to move forward. Increasing forward movement of the Joystick Control Lever will increase the speed of travel.
  - C. To reverse the direction, pull the Joystick Control Lever slightly back.
  - D. To turn, move the Joystick Control Lever toward the direction you want to turn.
  - E. To turn on a zero radius axis, go slowly and move the Joystick Control Lever to the side you wish to turn and slightly to the rear at the same time.



## **CAUTION**



**FOR SMOOTH, SAFE OPERATION, MOVE THE JOYSTICK CONTROL LEVER IN A GENTLE, SLOW MOTION. NEVER PULL OR PUSH THE JOYSTICK CONTROL LEVER RAPIDLY, ESPECIALLY ON GRADES.**

9. BRAKING: To brake mower, gently move the Joystick Control Lever in the direction opposite to travel. If the parking brake is engaged with the Joystick Control Lever in the "UP" position the engine will stop.
10. CUTTING HEIGHT ADJUSTMENT:

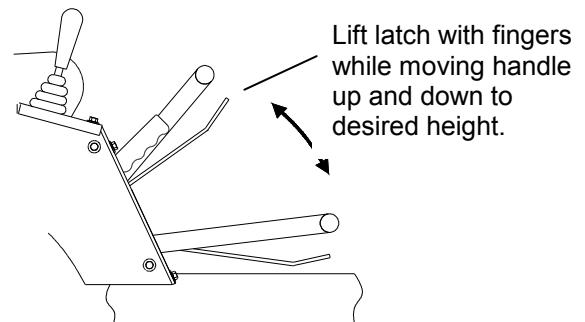

11. ENGAGE MOWER BLADE CLUTCH: Set the Blade Clutch Switch to the "ON" position. The engine will not start if the blade clutch is engaged. If the operator is not in the seat, the engine will stop if the clutch is engaged.

**!**     **CAUTION**     **!**

**AVOID HILL AND SLOPES. USE EXTREME CAUTION WHEN MOWING UP OR DOWN SLOPES. NEVER MOW ACROSS THE FACE OF A SLOPE. IF A SLOPE MUST BE ASCENDED, BACK UP THE SLOPE; DRIVE FORWARD WHEN DESCENDING.**

12. TO STOP:
- A. Move Joystick Control Lever to neutral position and then to the “DOWN” position.
  - B. Disengage the mower blade clutch by moving the clutch to the “OFF” position.
  - C. Set the parking brake.
  - D. Slow engine speed with throttle to slowest position.
  - E. Turn ignition key to “OFF” position.
  - F. Remove the key and wait for all movement and all sound to cease before dismounting.

**!**     **CAUTION**     **!**

**WHEN LEAVING THE MOWER UNATTENDED, ALWAYS REMOVE THE KEY AND SET THE PARKING BRAKE, EVEN IF JUST FOR A FEW MOMENTS. HELP PROTECT CHILDREN AND OTHER UNAUTHORIZED PERSONS FROM ACCIDENTS.**

13. TO FREE WHEEL MACHINE: UNLOCK TRANSMISSION: The Transmission Release Chains are located on each side of the mower on the rear of the Hydrostatic Drive Axles and below the Engine Mounting Plate. Pull the Transmission Release Chains back and then down into the retaining slot on the Hydrostatic Drive Mounting Angle (each side must individually be pulled back and down into the retaining slot). To re-engage the transmissions lift the Transmission Release Chains out of the retaining slots in the Hydrostatic Drive Mounting Angle.

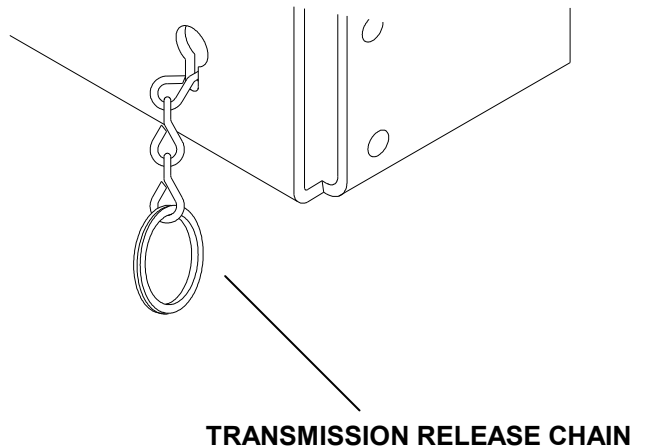

NOTE: The tractor should never be pulled at more than 2 miles per hour or for any appreciable distance.



## MOWING RECOMMENDATIONS

1. Keep mower blades sharp.
2. Make sure deck and discharge are clean.



3. When mowing tall grass, make two passes, mowing off 1/2 of the desired cut on the first pass, and then the desired height the second pass. Check for hidden dangers first.
4. Go slowly for trimming.
5. Always cut grass with the engine at full throttle speed. This "ENGINE" speed allows the cutting blades to operate at optimum cutting speed. Control "GROUND" speed with the Joystick Control Lever.
6. Vary ground speed to suit conditions (i.e. go slower in tall thick grass, on hills, wet conditions, etc.).

# MAINTENANCE



## CAUTION



**BEFORE PERFORMING ANY MAINTENANCE, TURN OFF ENGINE  
REMOVE KEY AND DISCONNECT SPARK PLUGS. USE EXTREME CARE WHEN WORKING ON  
MACHINERY. DO NOT WEAR WATCHES OR JEWELRY. DO NOT WEAR LOOSE FITTING  
CLOTHES, AND OBSERVE ALL COMMON SAFETY PRACTICES WITH TOOLS.**

### MAINTENANCE SCHEDULE

<i><b>SERVICE</b></i>	<i><b>WHEN</b></i>
Check crankcase oil level -----	before each use
Clean grass from Hydrostatic Transmission fins and cooling fans -----	before each use
Check air intake screen -----	after each use
Clean grass under deck -----	after each use
Check tire pressure -----	every 10 hours
Check battery fluid -----	every 10 hours
Sharpen mower blades -----	every 10 hours
Clean air filter pre-cleaner element -----	every 25 hours
Check drive belts -----	every 50 hours (20 hours break-in)
Service Air Cleaner Filter Element -----	every 100 hours
Change engine crankcase oil -----	100 hours
oil filter -----	200 hours
Replace air filter element -----	annually or 500 hours
Check spark plugs -----	annually or 500 hours
Service battery -----	annually or 500 hours
Grease Front Caster Spindles-----	before each use

-----

**Replace decals when illegible. Write factory for free replacement.**

## MAINTENANCE INSTRUCTIONS

### 1. ENGINE:

For complete maintenance and operating information for your engine, please refer to your engine operating and maintenance instructions furnished by the engine manufacturer and included in your **Country Clipper** Zero Turning Radius Mower information packet.

NOTE: Air intake screen must be kept clean. If plugged, engine may be seriously damaged by over heating.

### 2. BATTERY:

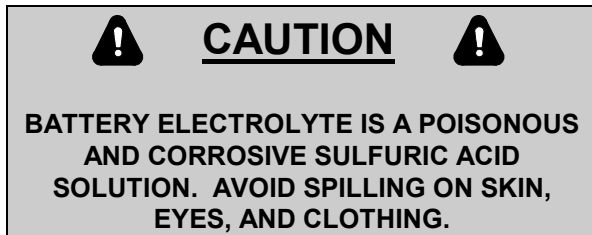

Keep the electrolyte level above the plates in each cell by adding distilled water as it becomes necessary. Add water just before operating the mower to mix the water with the solution. Be careful not to overfill the battery -- the electrolyte solution is corrosive and can cause damage to surrounding metal parts if it should spill. When taking the battery out of the mower for servicing, make sure to connect the cables to the battery exactly as they were prior to removal. Always disconnect the ground ( - ) wire first and always reconnect the ground ( - ) wire last.

Keep the battery clean. Remove the corrosion around the battery terminals by applying a solution of one part baking soda to four parts water. Coat all exposed terminal surfaces with a light layer of grease or petroleum jelly to prevent corrosion.

NOTE: At temperatures below 32 degrees F (0 degrees C) the full charge state must be maintained to prevent cell electrolyte from freezing and causing permanent battery damage.

### 3. TIRES:

Correct tire pressure is essential for efficient operation of the mower. Check tire pressure as requested in the maintenance schedule. Inflate tires to the pressures listed below:

Model	Front tires	Rear tires
All Models	12 psi	12 psi

Lug nuts should be torqued to 75 ft/lbs and checked regularly for tightness.

### 4. MOWER BLADES:

Check sharpness of mower blades after every 10 hours of operation. To sharpen blades proceed as follows:



- A. Remove bolt, lockwasher, and cup washer mounting blade on shaft. Remove blade.
- B. Blades should be discarded when worn excessively.

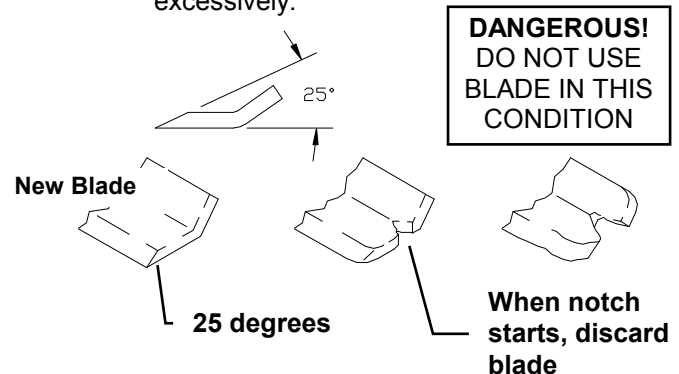

- C. Sharpen blades with a hand file, electric grinder or blade sharpener. Wear gloves and eye protection when sharpening. Grind blade at original 25 degree bevel.
- D. Check balance of blade by positioning the blade on a nail or blade balance pedestal. Grind the blade on the end that is heavier until both sides balance.
- E. Install blade, cup washer, lockwasher, and bolt. Make sure to tighten bolt to 60 ft.lbs.

## 5. V-BELTS:

All belts should be checked every 50 hours. Replace any belts found to be in poor condition. All belts are equipped with spring loaded belt tighteners and do not require tightening adjustments.

## 6. LUBRICATION:

- A. Engine: Follow engine manufacturer's recommendation.
- B. Deck Spindles: Lubricate with 3 "shots" only, every 100 hours. Do not over lubricate.

## 7. PARKING BRAKE ADJUSTMENT: SHOWN IN "ON: POSITION

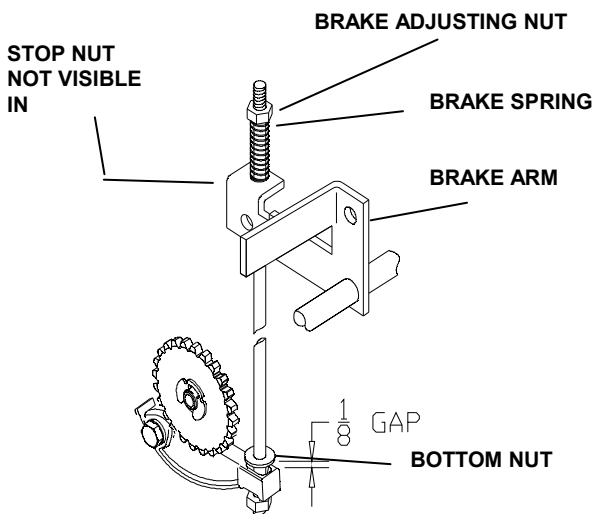

- A. Move Parking Brake Lever to the "ON" Position.
- B. Tighten the BOTTOM NUT until the Brake ROD can be moved up and down 1/8".
- C. Tighten the BRAKE ADJUSTING NUT until the BRAKE SPRING is collapsed 1/4".
- D. Turn the STOP NUT up until it comes in contact with the bottom of the BRAKE ARM.
- E. Repeat for the other side.

NOTE: With the Brake Lever in the "OFF" position the teeth of the brake disk mechanism should not be engaged.

## 8. JOYSTICK CONTROL LEVER NEUTRAL ADJUSTMENT:

With the engine running, if the machine travels in either direction when the Joystick Control Lever is in the neutral "DOWN" position, stop the engine, elevate the rear wheels clear of the ground and adjust as follows:

- A. Remove the right hand fender skirt exposing the Joystick Control Lever Assembly.
- B. Start the engine.
- C. Run engine at fast idle with Joystick Control Lever in the "DOWN" position.
- D. Loosen the locknuts tightened against the rod end ball joints on the Upper Linkage Rod Assembly that corresponds to the wheel that is turning. Note: One of these is a left hand nut and will have to be turned backwards.
- E. Adjust the Neutral Position by turning Assembly until the wheel stops turning.
- F. Retighten the locknuts on Upper Linkage Rod Assembly and check to make sure the drive wheel is still not turning.
- G. Repeat steps B through F for other side.

Shut off engine before removing from blocks. Replace fender skirt.

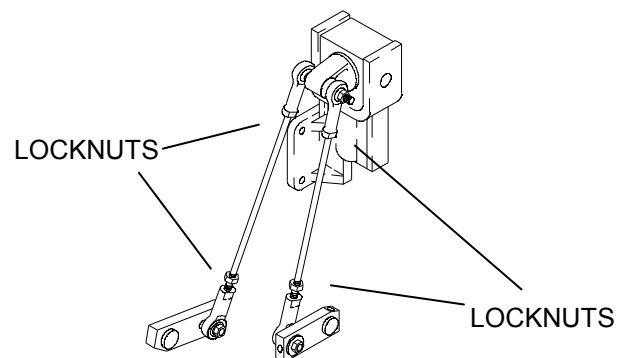

## 9. JOYSTICK CONTROL LEVER SENSITIVITY ADJUSTMENT

To change the sideways turning response adjust as follows:

- A. Remove the right hand fender skirt exposing the Joystick Control Lever assembly.
- B. Remove the cross bolt, nut, and spacers
- C. Reassemble the spacers as desired. (2) spacers between the rod end ball joints and the joystick pivot shaft will quicken the side to-side-response, (1) spacer slows the response.

**NOTE:** It is important that there is at least one spacer on each side of the rod end ball joints to prevent damage. Also the small diameter of the spacer must point towards the rod end ball joint.

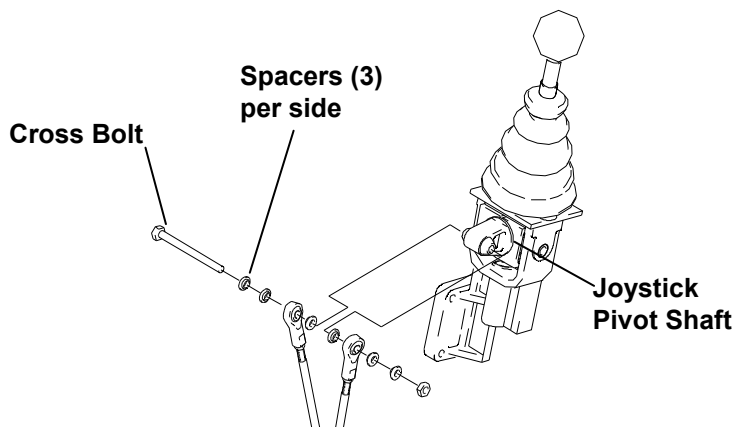

## 10. ADJUSTING FOR STRAIGHT FORWARD TRACKING:

In a large open area, actuate the Joystick Control lever into the full forward position. If the mower veers in either direction left or right some adjustment is necessary. If the mower veers to the right, then the right hydrostat needs to be sped up. If the mower veers to the left, then the left hydrostat needs to be sped up.

- A. Stop the machine and shut off the engine.
- B. Slightly loosen the NUT at the lower end of the upper linkage assembly on the side that is slower. Using a 1/8" hex wrench turn the SETSCREW ¼ turn in. It may take several test drives to get the mower to track straight forward.
- C. Once the tracking is to the operators liking, completely tighten the NUT on the control linkage assembly that was loosened earlier.
- D. Recheck to make sure neutral adjust has not been effected

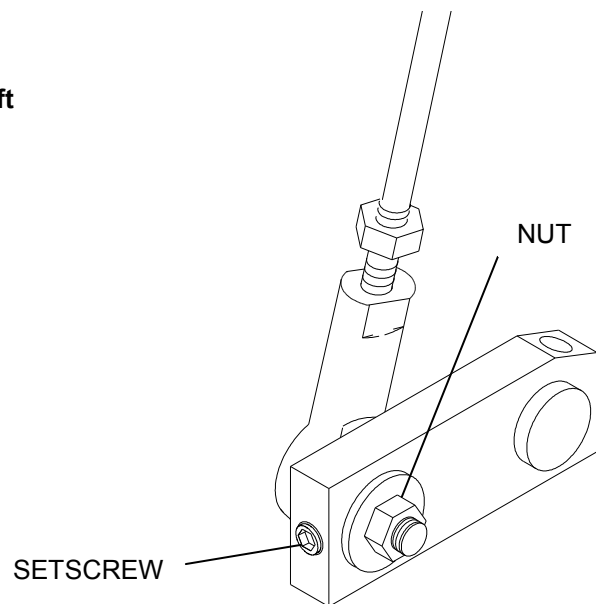

**11. JOYSTICK CONTROL LEVER  
DETENT ADJUSTMENT:**

If the Joystick Control Lever does not lock in the "UP" position, turn the detent adjustment screw clockwise until a desirable locking action is obtained. If the Joystick Control Lever is hard to slide up and down, turn the detent adjustment screw counter-clockwise until a desirable sliding action is obtained.

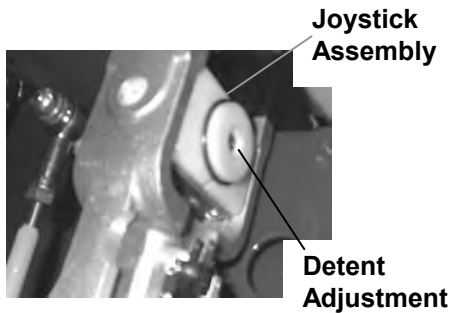

**12. HYDROSTATIC TRANSMISSIONS:**

Before each use, check to be sure that the cooling fins of the hydrostatic transmissions are clean. Excessive accumulation of oil, dirt, or trash may cause the transmissions to overheat. NEVER WASH ACROSS VENT HOSES with water or steam.



Hydrostatic Transmissions:  
Vent Hose

(one each side)

**BELT ROUTING**

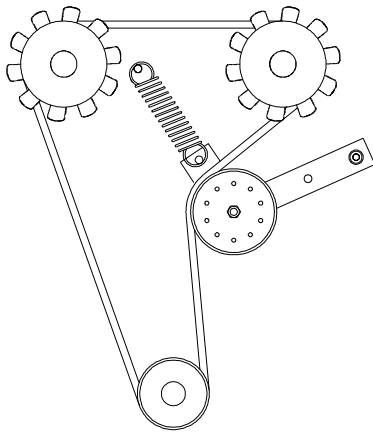

LOOKING UP FROM  
UNDER TRACTOR

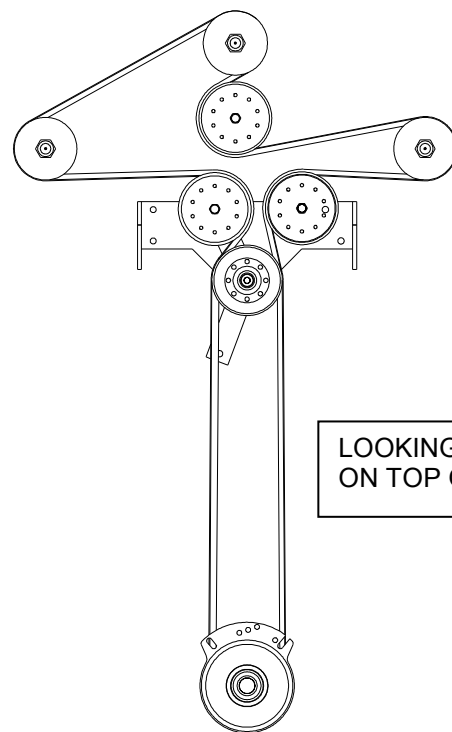

LOOKING DOWN  
ON TOP OF DECK

## PROCEDURE FOR RAISING AND LOWERING THE DECK FOR SERVICING

### 13. FLIPPING UP THE DECK:

- A. Park mower on hard flat surface.
- B. To remove the tension of the deck belt carefully rotate the RELEASE HANDLE on the left side of the deck From straight forward to straight back.
- C. Position the deck in the lowest notch. While holding the DECK LIFT HANDLE, move the SAFETY STOP to the left with your other hand, and push the DECK LIFT HANDLE all the way down, then release The SAFETY STOP.
- D. Reach under the engine and remove The deck drive belt from the clutch.

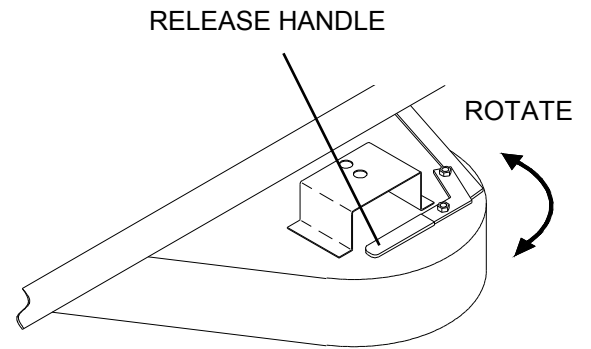

HANDLE SHOWN ABOVE SAFETY

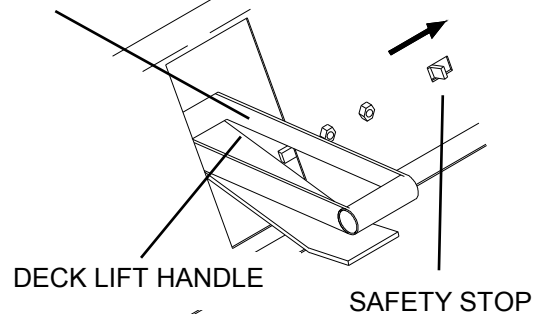

HANDLE SHOWN BELOW SAFETY STOP

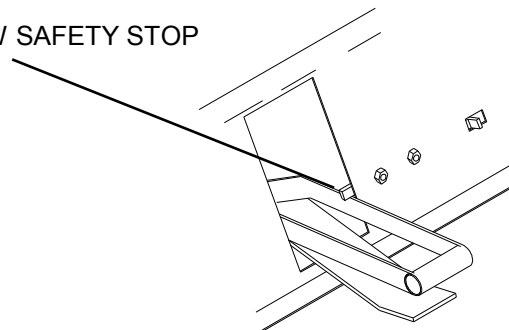

### **CAUTION**



DECK LIFT HANDLE IS SPRING LOADED UNDER TENSION WHEN DECK IS DISCONNECTED INTO FLIP UP MODE, OR REMOVED FROM TRACTOR.

- E. While standing in front of the tractor, with your feet apart, lift the front of the tractor. And the deck will swing out as shown. At this point set the tractor back down on top of the deck.

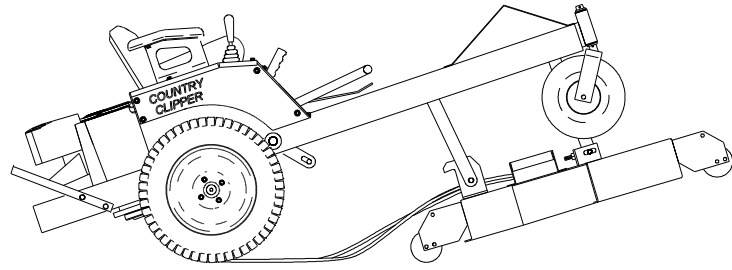

- F. Take hold of the front of the deck with both hands and lift straight up. The deck will fold out as illustrated.

**MOWER SHOWN IN  
SERVICING POSITION.**

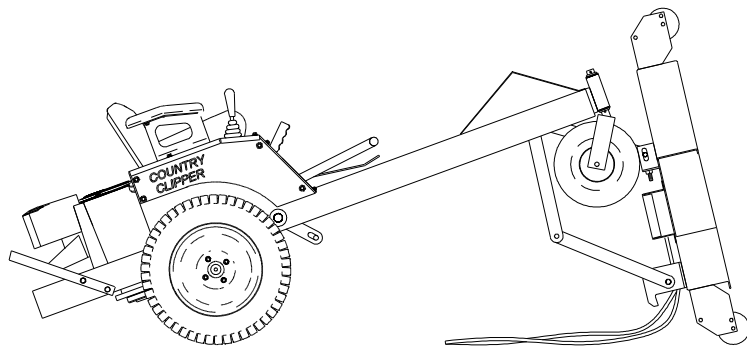

- G. To lower deck reverse process in section E and F.
- H. Feed the belt back over the two bars between the transmissions and put the belt back on the clutch pulley.
- I. Reverse process in section B.

**14. LEVELING THE DECK.**

- A. Set the tire pressure on all four tires.
- B. Set the deck in the top position. Rotate the blades by hand until the two outside blades face forward, (toward the front of the tractor.) Measure from the floor to the front of each blade. Turn the ADJUSTING NUT on each FRONT HANGER until both blades are approximately the same height.
- C. Set the "RAKE" by turning the ADJUSTING NUTS equal turns to lower the front of the deck.

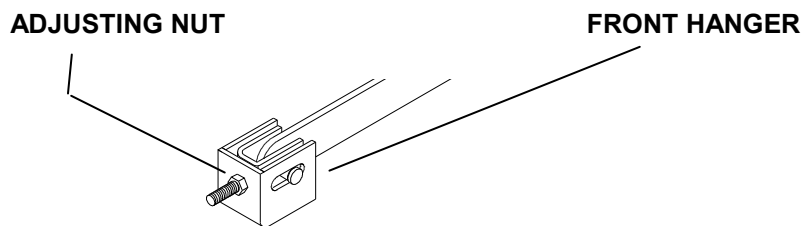



## TROUBLE SHOOTING CHECKLIST

1. ENGINE WON'T TURN OVER:
  - Mower blades engaged ----- disengage blades
  - Drive not in neutral --- move Joystick Control Lever to neutral "DOWN" position
  - Blown fuse ----- replace fuse
  - Dead battery ----- charge or replace
  - Solenoid ----- consult dealer
  - Ignition switch ----- consult dealer
  - Starter ----- consult dealer
  
2. ENGINE WILL TURN OVER BUT WON'T START:
  - No gas ----- refuel
  - clean or replace fuel filters
  - Over or under choked ----- adjust choke
  - Spark plug not firing ----- check spark plug
  - condition and reset gap\*
  - Carburetor maladjustment ----- reset carburetor adjustment\*
  - Ignition switch ----- consult dealer
  
3. HARD TO START ENGINE:
  - Fuel line clogged ----- clean fuel line and check fuel filter
  - Faulty fuel pump ----- consult dealer
  - Spark plug wire loose or grounded ----- check spark plug wires
  - Spark plug(s) faulty or improperly gapped ----- check spark plug
  - condition and reset gap\*
  - Electronic ignition defective ----- consult dealer
  - Dirty or maladjusted carburetor ----- readjust carburetor\*
  - consult dealer for carburetor service
  
4. ENGINE STARTS BUT CUTS OUT:
  - Water in gasoline ----- drain old gasoline and replace with new gasoline
  - clean carburetor bowl
  - Clogged fuel line ----- check fuel filter
  - clean fuel line
  - Vent in fuel cap plugged ----- check vent
  - Faulty fuel pump ----- consult dealer
  - Maladjusted carburetor ----- readjust carburetor\*
  - Engine dies when Joystick Control Lever is pulled "UP" ----- parking brake set
  - release brake
  
5. ENGINE KNOCKS:
  - Low oil level ----- check and add oil
  - Ignition timing off ----- consult dealer
  - Fuel octane too low ----- drain and replace with
  - higher octane gasoline
  - Over heated engine ----- shut off engine and allow to cool

\* See engine manual for engine adjustments.



# WIRING SCHEMATIC FOR SR100 AND OLDER MODELS

Black wires = Ground  
 Red wires = Power  
 Blue wires = Kill Circuit  
 Yellow wires = Start Circuit  
 Green wires = Signal Circuit

## BRAKE SWITCH

(VIEWED FROM WIRE SIDE OF CONNECTOR)

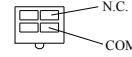

## KOHLER ENGINE PLUG #2

(VIEWED FROM WIRE SIDE OF CONNECTOR)



KOHLER ENGINE PLUG, CHARGE  
 KOHLER ENGINE PLUG, GROUND MAGNETO  
 KOHLER ENGINE PLUG, FUEL SOLENOID  
 KOHLER ENGINE PLUG, OIL PRESSURE SWITCH

## KOHLER ENGINE PLUG #1

(VIEWED FROM WIRE SIDE OF CONNECTOR)

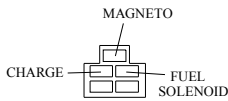

KOHLER ENGINE PLUG, CHARGE  
 KOHLER ENGINE PLUG, GROUND MAGNETO  
 KOHLER ENGINE PLUG, FUEL SOLENOID

## PTO SWITCH

(VIEWED FROM WIRE SIDE OF CONNECTOR)

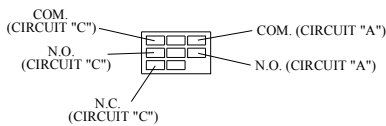

## IGNITION SWITCH

(VIEWED FROM WIRE SIDE OF CONNECTOR)

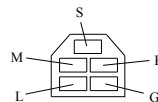

START SWITCH POSITION		CIRCUIT "MAKE"
OFF		G+M
ON		B+L
START		B+L+S

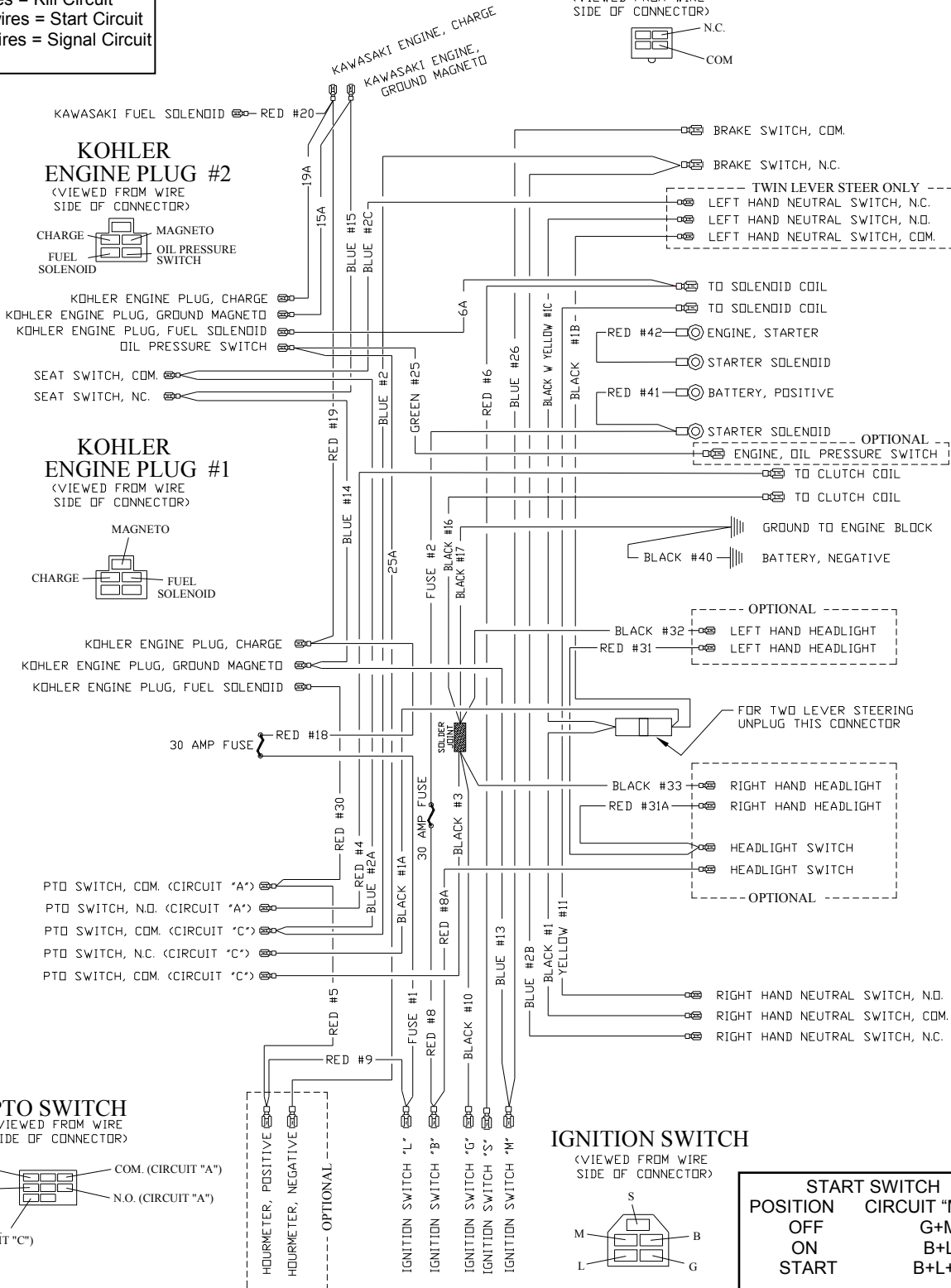

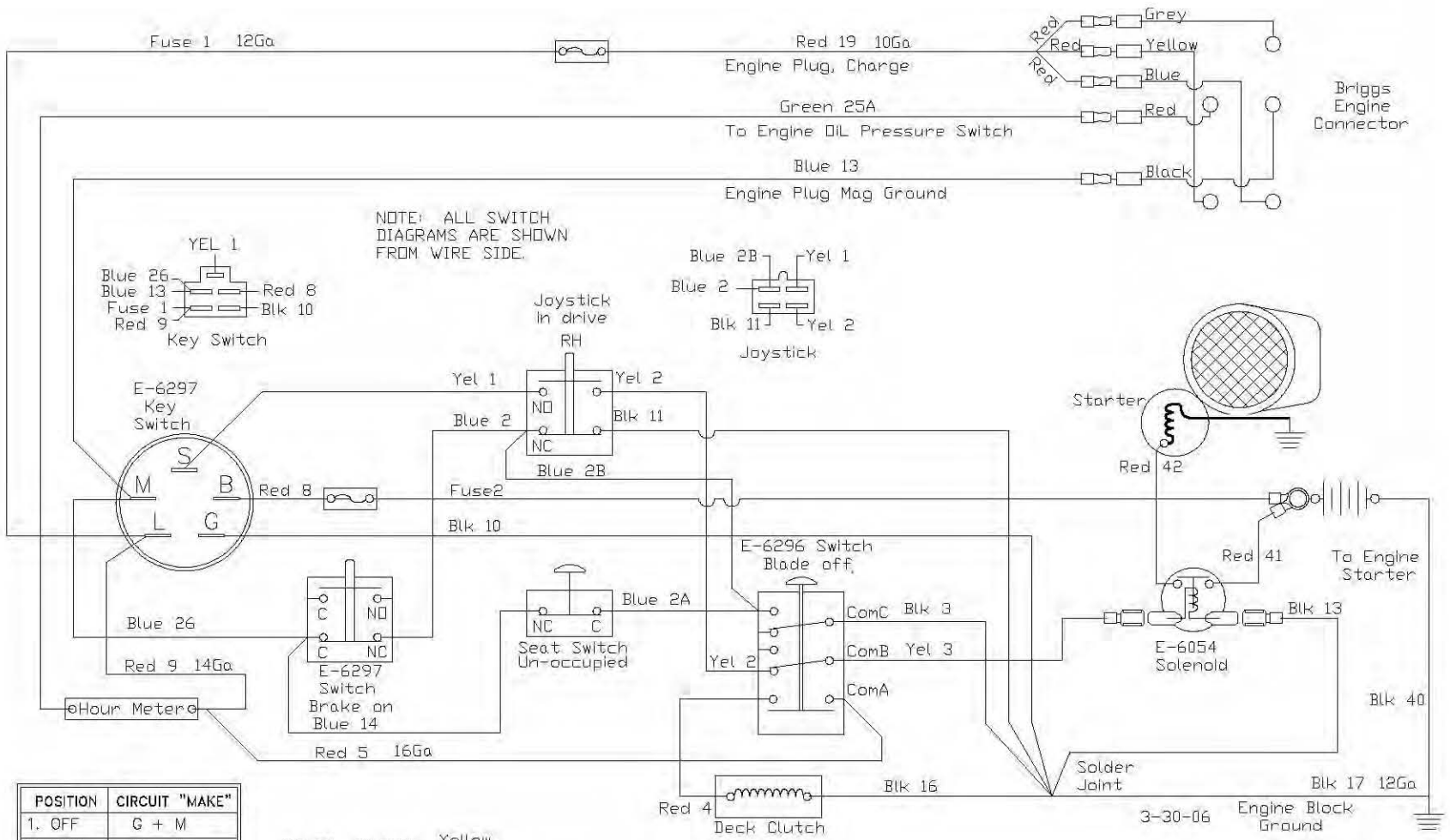

NOTE: ALL SWITCH DIAGRAMS ARE SHOWN FROM WIRE SIDE.

POSITION	CIRCUIT "MAKE"
1. OFF	G + M
2. RUN	B + L
3. START	B + L + S

Start Circuit Yellow  
 Safety Circuit Blue  
 Power Circuit Red

To Start: Clutch not engaged & Steering Levers in Neutral  
 Engine Kill: If Steering levers in drive & brake is on or seat un-occupied  
 If Clutch is on and seat is not occupied



# COUNTRY CLIPPER<sup>®</sup>

Zero Turn Radius Mower

# JAZZEE<sup>®</sup>

## ONE

## SR100

## SR105

## SR110



### WARNING



The engine exhaust from this product contains chemicals known to the State of California to cause cancer, birth defects, or other reproductive harm.

**Country Clipper Division**  
Shivvers Manufacturing Inc.  
613 W. English St.

Corydon, IA 50060-0467  
Ph. 641-872-2544 \*\* Fax. 641-872-1593