

REPAIR PARTS MANUAL

for

**COUNTRY**  
**CLIPPER**®

**JAZZEE**™

SR205

**JAZZEE**™  
**PRO**

SR355



**COUNTRY CLIPPER  
"JAZEE "  
AND  
"JAZEE PRO "  
ZERO TURN RADIUS MOWER**

**TABLE OF CONTENTS**

**PAGE.... CONTENTS**

**SECTION 1 – MOWER DECKS AND RELATED PARTS**

- 1-1. . . . DOUBLE IDLER STYLE DECK ASSEMBLY
- 1-2 . . . DECK SPINDLE ASSEMBLY
- 1-3 . . . DOUBLE IDLER STYLE DRIVE BELT IDLER & RELATED PARTS
- 1-4. . . LIFT HANDLE ASSEMBLY & RELATED PARTS
- 1-5 . . . LIFT ASSEMBLY & RELATED PARTS
- 1-6. . . TRANSMISSION IDLERS & RELATED PARTS

**SECTION 2 –TRACTOR FRAME AND RELATED PARTS**

- 2-7. . . . CASTER WHEEL ASSEMBLY
- 2-8. . . . FRAME SIDES & RELATED PARTS FOR JAZEE SR205
- 2-9. . . . FRAME SIDES & RELATED PARTS FOR JAZEE PRO SR355
- 2-10. . . FENDER ASSEMBLY
- 2-11. . . SEAT, FOOT DECK & RELATED PARTS

**SECTION 3 –TRACTOR DRIVE AND RELATED PARTS**

- 3-12. . . FUEL TANK ASSEMBLY
- 3-13. . . JOYSTICK STEERING CONTROL & RELATED PARTS
- 3-14. . . JOYSTICK STEERING CONTROL & RELATED PARTS FOR JAZEE SR205
- 3-15. . . JOYSTICK STEERING CONTROL & RELATED PARTS FOR JAZEE PRO SR355
- 3-16. . . RIGHT HAND STEERING CONTROL AND RELATED PARTS
- 3-17. . . LEFT HAND STEERING CONTROL AND RELATED PARTS
- 3-18. . . PARKING BRAKE ASSEMBLY & RELATED PARTS FOR JAZEE SR205
- 3-19. . . PARKING BRAKE ASSEMBLY & RELATED PARTS FOR JAZEE PRO SR355
- 3-20. . . MOTOR AND TRANSMISSION ASSEMBLY & RELATED PARTS FOR JAZEE SR205
- 3-21. . . MOTOR AND TRANSMISSION ASSEMBLY & RELATED PARTS FOR JAZEE PRO SR355
- 3-22. . . E-6405 WIRE HARNESS & RELATED PARTS (18.5 HP & 22 HP BRIGGS)
- 3-23. . . E-6415 WIRE HARNESS & RELATED PARTS (19 & 21 HP KAWA. & 23 HP BRIGGS & KOHLER)
- 3-24. . . E-6416 WIRE HARNESS & RELATED PARTS (19 & 21 HP KAWA. & 23 HP BRIGGS & KOHLER)
- 3-25. . . E-6417 KAWASAKI ADAPTER HARNESS & RELATED PARTS
- 3-26. . . E-6436 BRIGGS ADAPTER HARNESS & RELATED PARTS FOR (23 HP BRIGGS)

42", 48", 52", & 60"  
DECK ASSEMBLY  
WITH DOUBLE IDLER

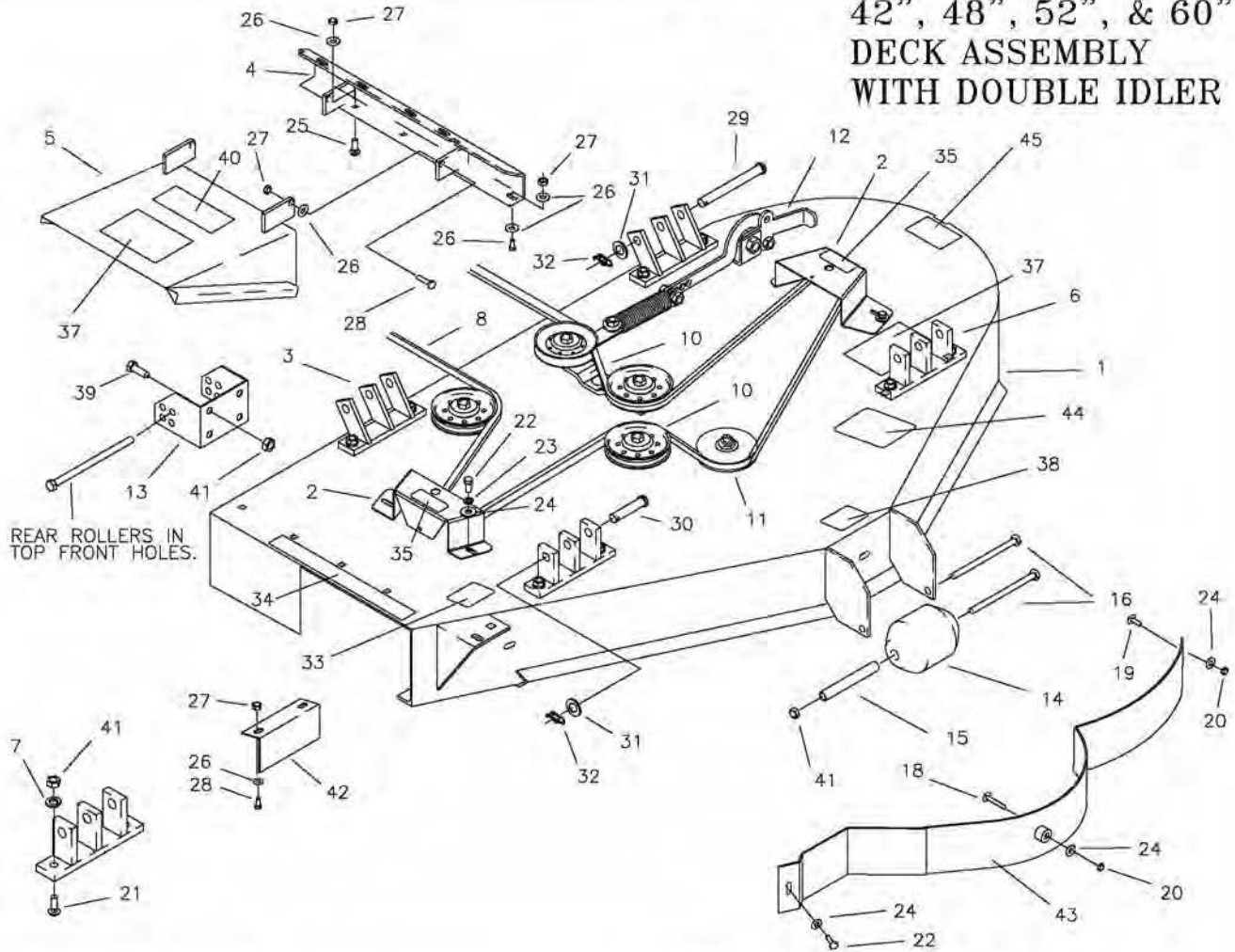

REF NO.	PART NO.	QTY.	DESCRIPTION	REF NO.	PART NO.	QTY.	DESCRIPTION
1	660-041A	1	42" DECK, W/DECALS	23	F-1019-01	1	1/4" LOCKWASHER
	660-042A	1	48" DECK, W/DECALS	24	F-1009-01	1	1/4" FLAT WASHER
	660-080A	1	52" DECK, W/DECALS	25	F-1671	1	CARRIAGE BOLT 5/16 X 3/4
	660-079A	1	60" DECK, W/DECALS	26	F-1009-02	1	5/16" FLAT WASHER
2	660-052A	1	42" LH PULLEY COVER, W/DECAL	27	F-1125	1	5/16-18 LOCKNUT
	660-053A	1	42" RH PULLEY COVER W/DECAL	28	F-1015-15	1	5/16-18 X 1" GR. 5
	660-054A	1	48" & 52" LH PULLEY COVER W/DECAL	29	H-2240	1	PIN, 1/2" X 4-1/2"
	660-055A	1	48" & 52" RH PULLEY COVER W/DECAL	30	F-1889	1	PIN, 1/2" X 2-1/2"
	668-024A	2	60" PULLEY COVER, W/DECAL	31	F-1521	1	1/2" FLAT WASHER
3	651-009W	2	DECK HANGER	32	H-2239	1	RUE RING 1/2"
4	649-012W	1	OUTLET STIFFENER	33	P-10947	1	DECAL, "GREASE SPINDLE"
5	649-054A	1	DECK CHUTE W/DECAL	34	P-10122	1	DECAL, "MISSING CHUTE"
6	643-016W	2	DECK HANGER	35	P-10935	2	DECAL, "ROTATING..."
7	F-1019-03	1	3/8 LOCK WASHER	37	P-10941	2	DECAL, "MULTI PERIL"
8	D-3727-W	1	V-BELT, A-144, WRAPPED (42")	38	P-11413	1	DECAL, "HOIST POINT"
	D-3733-W	1	V-BELT, A-158, WRAPPED (48")	39	F-1394	1	3/8-16 X 1" GR. 5
	D-3776-W	1	V-BELT, B-180, WRAPPED (52" & 60")	40	P-10937	1	DECAL, "WARNING"
10	-----	1	DOUBLE IDLER ASSEMBLY (SEE PG.1-3)	41	F-1005-03	1	LOCKNUT, 3/8 STOVER
11	-----	3	SPINDLE ASSEMBLY (SEE PG.1-2)	42	651-023P	1	AIR BAFFLE (42")
12	-----	1	BELT TIGHTING SYSTEM (SEE PG.1-3)		629-230P	1	AIR BAFFLE (48" & 52")
13	609-182P	2	REAR SCALPER BRACKET (42")		643-042P	1	AIR BAFFLE (60")
14	H-1948	5	ROLLER, 3-3/4 DIA. X 4-13/16	43	651-022W	1	DUST BAFFLE WLDT, 42"
15	609-183P	5	WHEEL BUSHING		629-241W	1	DUST BAFFLE WLDT, 48"
16	F-1741	1	3/8-16 X 6" GR. 5		629-229W	1	DUST BAFFLE WLDT, 52"
17	F-1239	1	3/8 LOCKNUT		643-047W	1	DUST BAFFLE WLDT, 60"
18	F-1935	1	CARRIAGE BOLT, 1/4 X 1 1/2	44	P-11932	1	DECAL, BELT ROUTING
19	F-1823	1	CARRIAGE BOLT, 1/4 X 3/4	45	P-11949	1	DECAL, DECK SIZE 42"
20	F-1158	1	LOCKNUT, 1/4-20		P-11950	1	DECAL, DECK SIZE 48"
21	F-1672	1	CARRIAGE BOLT, 3/8 X 1-1/4		P-11951	1	DECAL, DECK SIZE 52"
22	F-1538	1	1/4-20 X 3/4 GR. 5		P-11952	1	DECAL, DECK SIZE 60"

# DECK SPINDLE ASSEMBLY

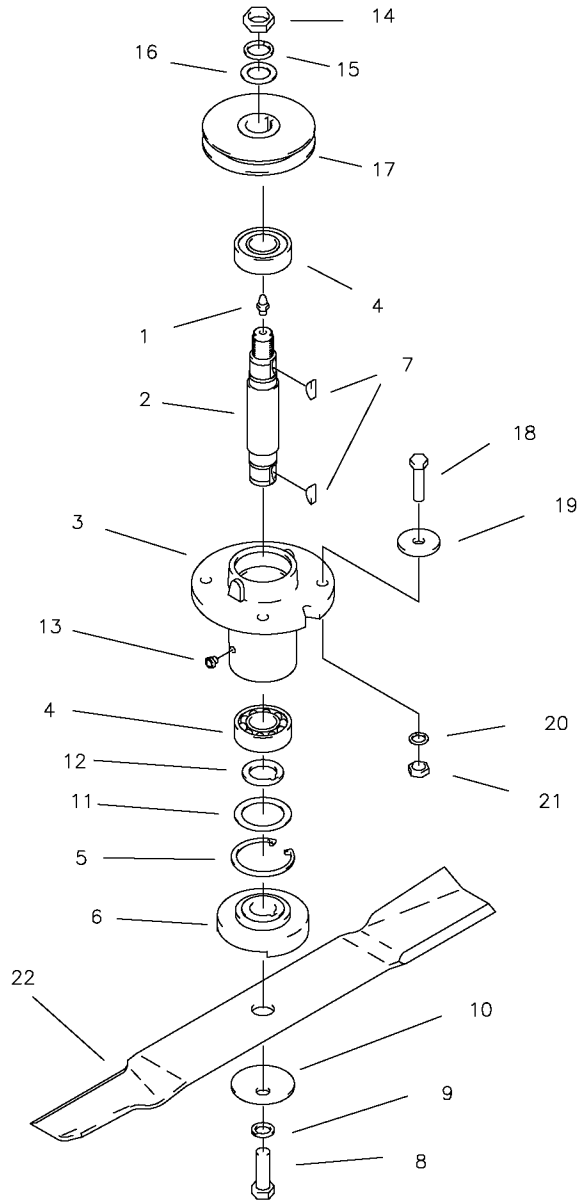

REF NO.	PART NO.	QTY.	DESCRIPTION	REF NO.	PART NO.	QTY.	DESCRIPTION
-	660-045A	-	SPINDLE ASSEMBLY	18	F-1572	4	3/8-24 X 1-1/2" HHCS GR. 5
1	H-1056	1	GREASE FITTING	19	609-034P	4	SPINDLE SPACER REINFORCEMENT
2	609-162P	1	SPINDLE SHAFT	20	F-1019-03	4	3/8" LOCK WASHER
3	660-028P	1	SPINDLE HOUSING, FLAT	21	F-1573	4	3/8-24 LOCKNUT, M-F
4	D-3058	2	BEARING, #6205-2RS	22	H-1714	1	BLADE, HIGH L, 17" CUT 48"
5	H-1893	1	SNAP RING INT. 52MM	-	H-1715	-	BLADE, HIGH L, 15" CUT 42"
6	609-152P	1	BLADE SPACER	-	H-2246	-	BLADE, HIGH L, 18 3/8" CUT 52"
7	D-1004-02	2	KEY, WOODRUF, 1/4 X 3/4	-	H-1708	-	BLADE, HIGH L, 21" CUT 60"
8	F-1526	1	1/2-13 X 1-1/2" HHCS GR. 5	-		-	OPTIONAL BLADES
9	F-1464	1	1/2" LOCK WASHER	H-1666	-	-	BLADE, LOW L, 17" CUT 48"
10	F-1507	1	WASHER, 1/2" CUPPED	H-1665	-	-	BLADE, LOW L, 15" CUT 42"
11	609-151P	1	WASHER, SEAL	H-2387	-	-	BLADE, LOW L, 18 3/8" CUT, 52"
12	609-073P	1	ARBOR SPACER	H-1667	-	-	BLADE, LOW L, 21" CUT, 60"
13	H-2066	1	GREASE VENT 5 LBS.				
14	F-1461	1	3/4-16 NUT, HEX JAM	H-2013	-	-	BLADE, GATOR, 15" CUT 42"
15	F-1463	1	3/4" LOCK WASHER	H-2202	-	-	BLADE, GATOR, 17" CUT 48"
16	F-1510	1	3/4" WASHER, FLAT STD.	H-2251	-	-	BLADE, GATOR, 18 3/8" CUT 52"
17	D-3732-01	1	SPINDLE PULLEY, 42"	H-2122	-	-	BLADE, GATOR, 21" CUT 60"
	609-155P	-	SPINDLE PULLEY, 48"				
	D-3732-03	-	SPINDLE PULLEY, 52"	23	629-237P	2	WASHER, .406 ID X 1"
	668-012P	-	SPINDLE PULLEY, 60"	24	609-223P	1	SPINDLE HOUSING,

# DOUBLE IDLER DRIVE BELT IDLER & RELATED PARTS

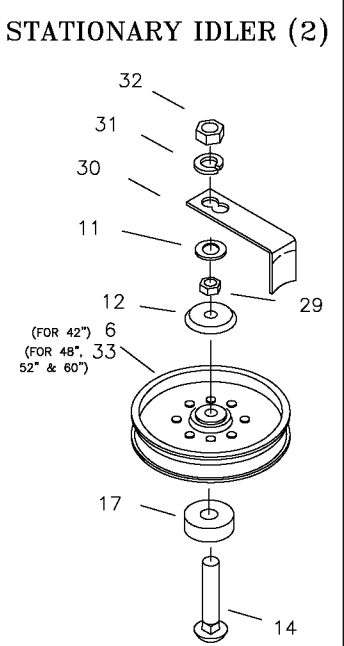
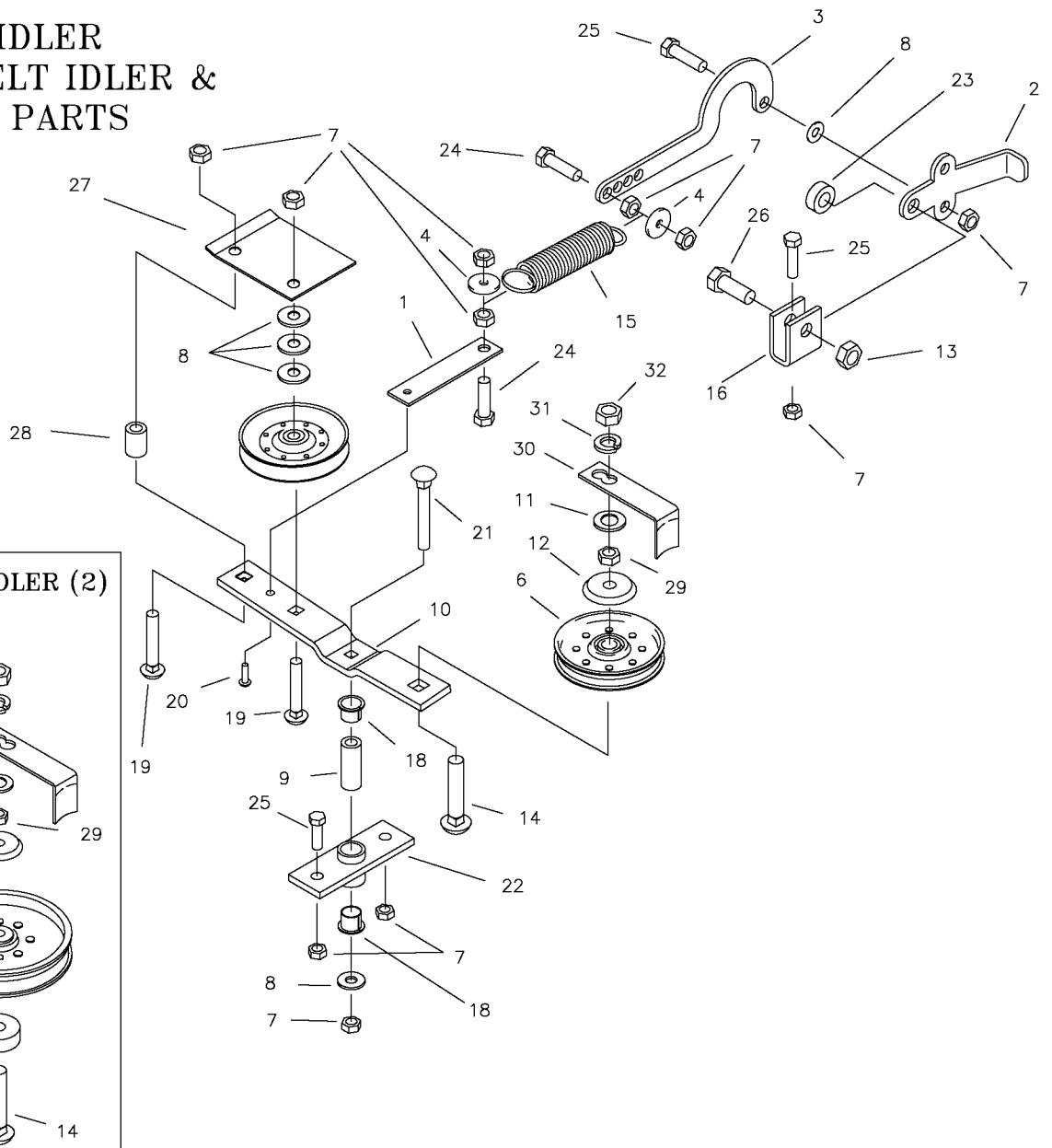

REF NO.	PART NO.	QTY.	DESCRIPTION	REF NO.	PART NO.	QTY.	DESCRIPTION
1	660-035P	1	EXTENSION FOR SPRING	22	660-039P	1	MOUNT, DOUBLE IDLER
2	660-030P	1	HANDLE, BELT TIGHTENER	23	660-038P	1	3/8" THICK SPACER
3	660-031P	1	ARM, BELT TIGHTENER	24	F-1307	2	3/8-16 X 1-1/4" GR. 5
4	609-034P	2	SPINDLE SPACER REINFORCEMENT	25	F-1394	4	3/8-16 X 1" GR. 5
5	D-3758	1	"V" IDLER PULLEY	26	F-1526	1	1/2-13 X 1-1/2" GR. 5
6	D-3338	2	IDLER PULLEY	27	668-022P	1	BELT GUARD
7	F-1005-03	11	3/8 LOCK NUT	28	668-021P	1	SPACER, BELT GUARD
8	F-1009-03	5	3/8 FLAT WASHER	29	F-1966	2	1/2" THIN NYLOC NUT
9	659-085P	1	MOUNTING PIN	30	660-060P	2	BELT KEEPER
10	660-036P	1	IDLER ARM	31	F-1464	2	1/2" LOCK WASHER
11	F-1521	4	1/2" FLAT WASHER	32	F-1489	2	1/2" THIN NUT
12	620-201P	3	BEARING CAP	33	D-3774	1	IDLER PULLEY, 5" DIA
13	F-1005-05	4	1/2" LOCK NUT				
14	F-1927	1	1/2-13 X 2-3/4" CARRIAGE BOLT				
15	H-2092	1	SPRING				
16	661-015P	1	SHACKLE				
17	660-037P	1	1/2" THICK SPACER				
18	D-3730	2	BUSHING, TEFLON COATED				
19	F-1177	2	3/8-16 X 1-1/2" CARRIAGE BOLT				
20	F-1733	1	1/4" DRIVE STUD				
21	F-1865	1	3/8-16 X 2-1/2" CARRIAGE BOLT				

# LIFT HANDLE ASSEMBLY & RELATED PARTS

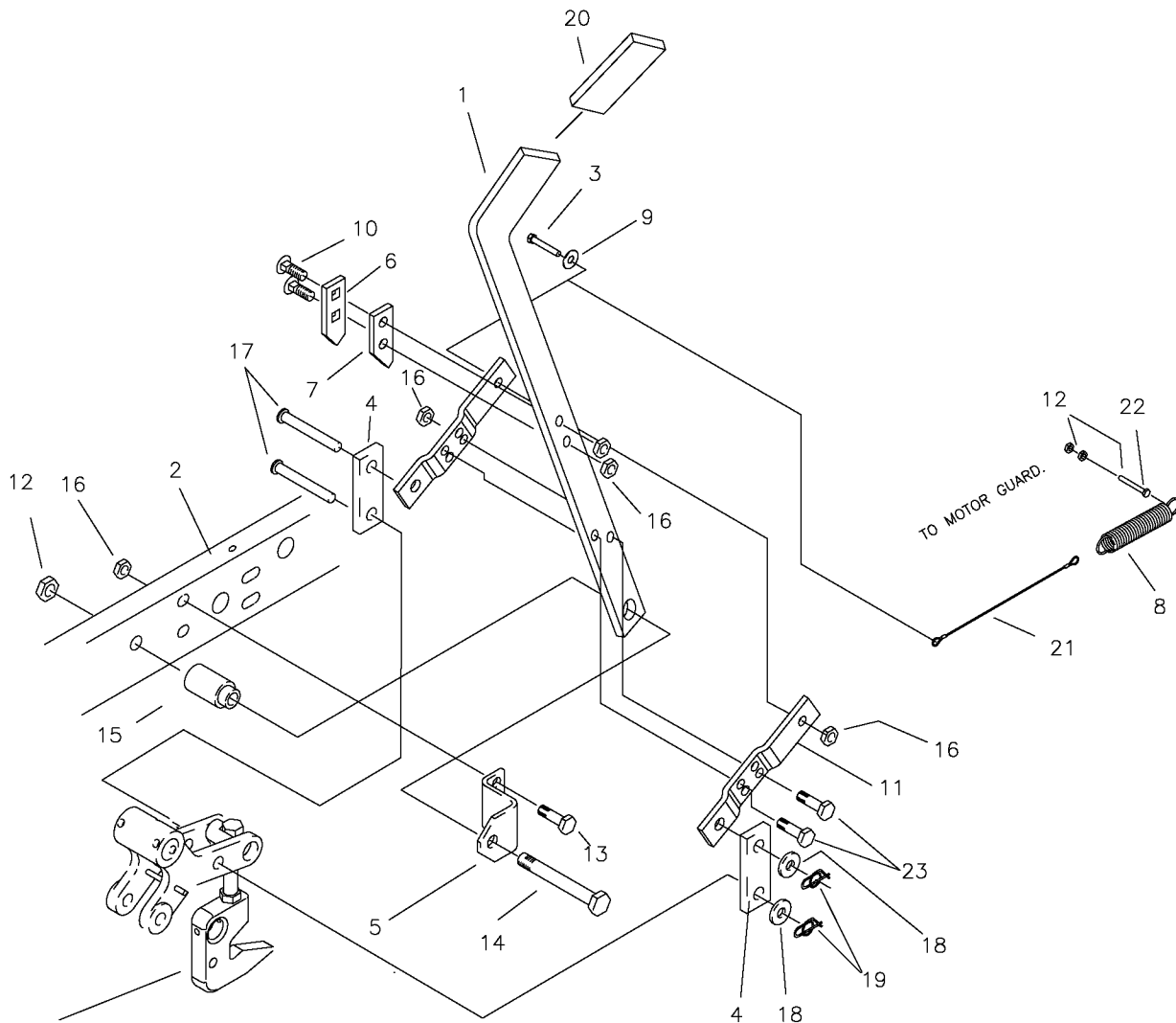

SEE ASSEMBLY NUMBER  
PAGE 1-5

REF NO.	PART NO.	QTY.	DESCRIPTION	REF NO.	PART NO.	QTY.	DESCRIPTION
1	659-060P	1	LIFT HANDLE	15	642-095P	1	HANDLE PIVOT PIN
2	659-022W	1	FRAME WELDMENT, LH.	16	F-1005-03	5	NUT, 3/8-16 LOCKNUT (STOVER)
3	F-1073	1	3/8-18 X 2" GR 5	17	F-1889	2	CLEVIS PIN, 1/2 X 2 5/8"
4	642-061P	2	HANDLE LINK	18	F-1521	2	1/2" FLAT WASHER
5	642-041P	1	HANDLE PIVOT BRACKET	19	H-2239	2	RUE RING, 1/2"
6	642-127P	1	TOP PEG LATCH PLATE	20	H-2324	1	VINYL GRIP, 3/8 X 1 1/2"
7	642-126P	1	TOP PEG SPACER PLATE	21	H-2460	1	CABLE
8	H-1610	1	SPRING, 1 1/2" OD. X 8"	22	F-1293	2	1/2-13 X 1 1/2" GR. 5
9	F-1009-03	1	FLAT WASHER, 3/8"	23	F-1307	2	1/2-13 X 1 1/4" GR. 5
10	F-1672	2	CARRIAGE BOLT, 3/8-16 X 1 1/4"				
11	659-049P	2	SPRING ANCHOR PLATE				
12	F-1005-05	3	NUT, 1/2-13 LOCKNUT				
13	F-1558	2	3/8-16 X 7/8" GR. 5				
14	F-1439	1	1/2-13 X 3" GR. 5				

# LIFT ASSEMBLY & RELATED PARTS

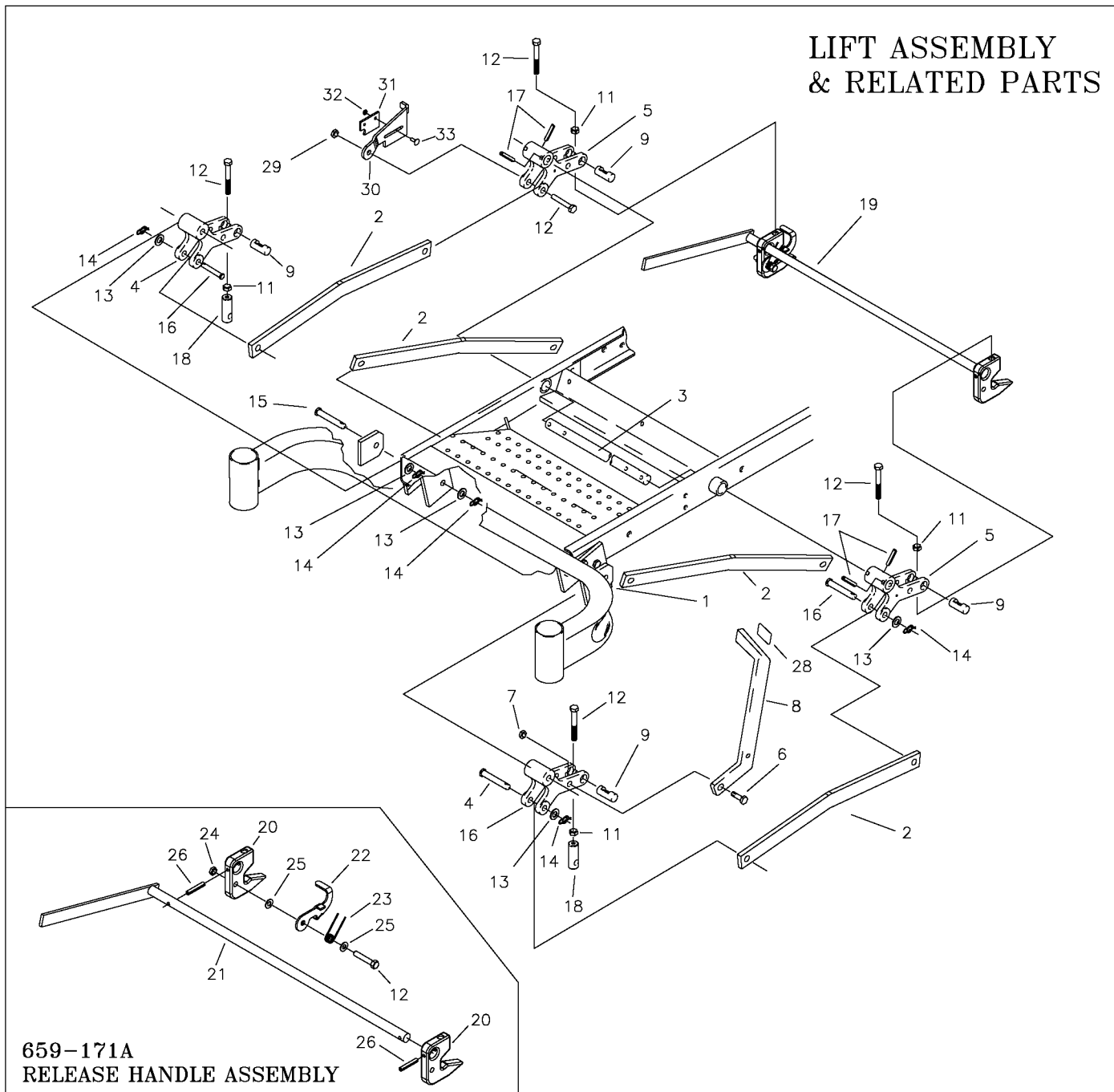

REF NO.	PART NO.	QTY.	DESCRIPTION	REF NO.	PART NO.	QTY.	DESCRIPTION
1	642-063P	2	DRAG BAR TAB	18	642-175P	2	ADJUSTABLE HANGER END
2	659-155P	4	DRAG LINK BAR	19	659-171A	1	RELEASE HANDLE ASSEMBLY
3	620-051P	1	LIFT BAR	20	659-140P	2	DECK HOOK
4	642-081P	2	LIFT SLEEVE, FRONT	21	659-148W	1	RELEASE HANDLE WELDMENT
5	642-082P	2	LIFT SLEEVE, REAR	22	659-145P	1	HOOK KEEPER
6	F-1879	1	5/16-18 X 1 1/4" GR.5	23	H-2547	1	SPRING, TORSION
7	F-1125	1	5/16-18 STOVER NUT	24	F-1005-03	1	NUT, 3/8-16, STOVER
8	659-056P	1	DECK LIFT PEDAL	25	F-1009-03	2	WASHER, FLAT, 3/8"
9	642-177P	4	HANGER PIN	26	F-2009	2	SPIROL ROLL PIN 1/4 X 1-1/2
10	F-1896	2	CLEVIS PIN, 1/2 X 1 3/4"	27	F-1073	1	CAPSCREW, 3/8-16 X 2, GR. 5
11	F-1489	4	NUT. 1/2" JAM	28	H-2401	1	TREAD PAD
12	F-1936	6	1/2-13 X 3 1/2, 2" THREAD	29	F-1005-05	1	1/2" STOVER NUT
13	F-1521	8	WASHER, 1/2 NARROW	30	659-146P	1	LATCH PLATE
14	H-2239	8	RUE RING, 1/2"	31	659-170P	1	PLATE, CATCH
15	F-1890	2	CLEVIS PIN, 1/2 X 3 1/2"	32	F-1158	2	NUT, 1/4" STOVER
16	F-1898	3	CLEVIS PIN, 1/2 X 2 3/4"	33	F-1823	2	CARRIAGE BOLT, 1/4-20 X 3/4"
17	F-1036-37	4	ROLL PIN, 5/16 DIA. X 1.750				

## TRANSMISSION IDLERS & RELATED PARTS

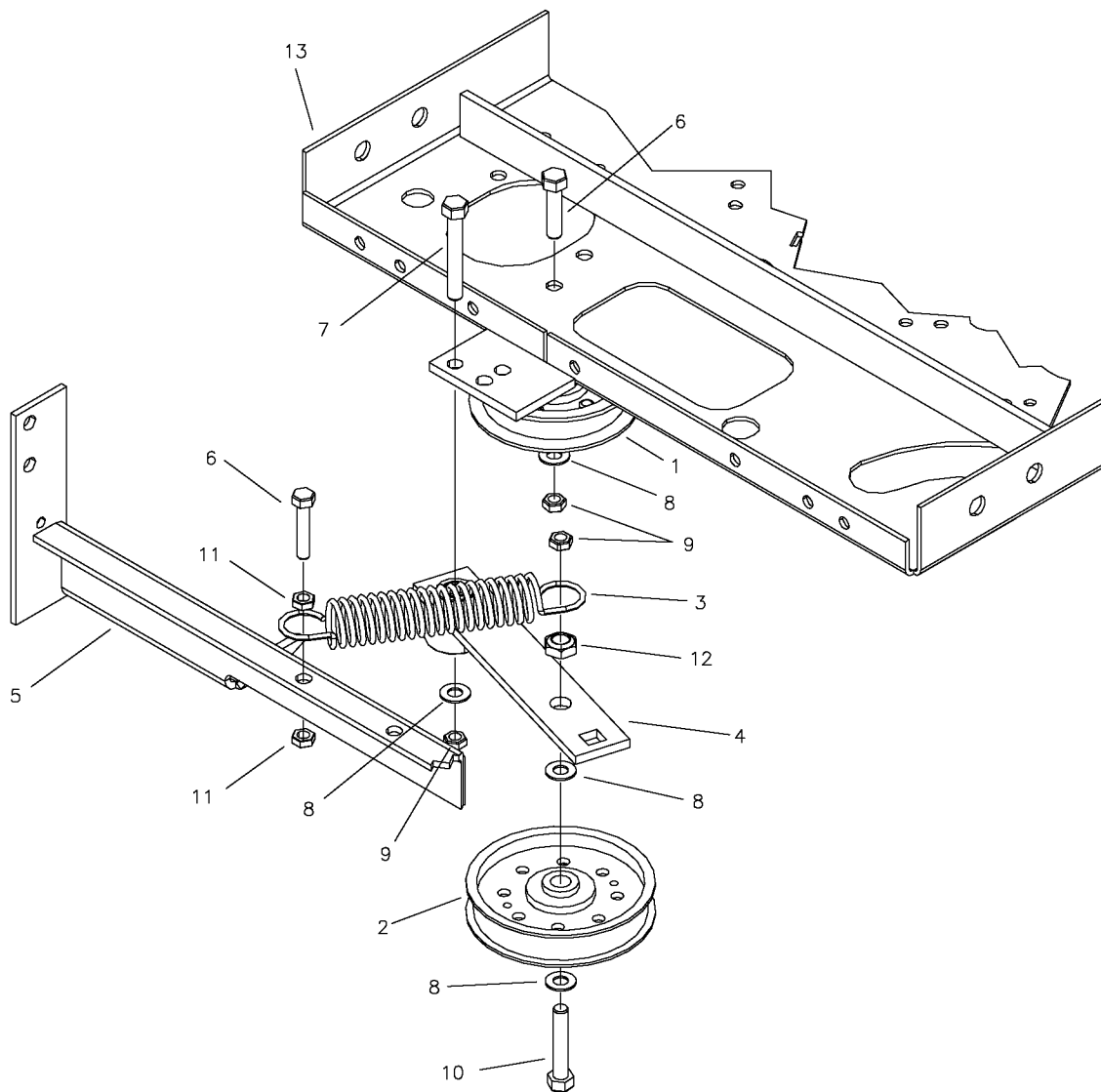

REF NO.	PART NO.	QTY.	DESCRIPTION
1	D-3768	1	PULLEY, 3-1/2" X 1"
2	D-3617	1	PULLEY, FLAT IDLER, 1/2" BORE, 4"
3	H-2092	1	SPRING, 1 1/4 X 5"
4	661-090A	1	IDLER ARM ASSEMBLY
5	659-160W	1	BRACE WELDMENT
6	F-1015-17	2	5/16-18 X 1-1/2" GR. 5
7	F-1015-30	1	3/8-16 X 2-1/2" GR. 5
8	F-1009-03	4	3/8" FLAT WASHER
9	F-1005-03	3	3/8" STOVER LOCK NUT
10	F-1073	1	3/8-16 X 2" GR. 5
11	F-1125	2	5/16" STOVER LOCK NUT
12	F-1966	1	1/2" THIN NYLOC NUT
13	659-174W	1	MOTOR MOUNT WELDMENT



# CASTER WHEEL ASSEMBLY

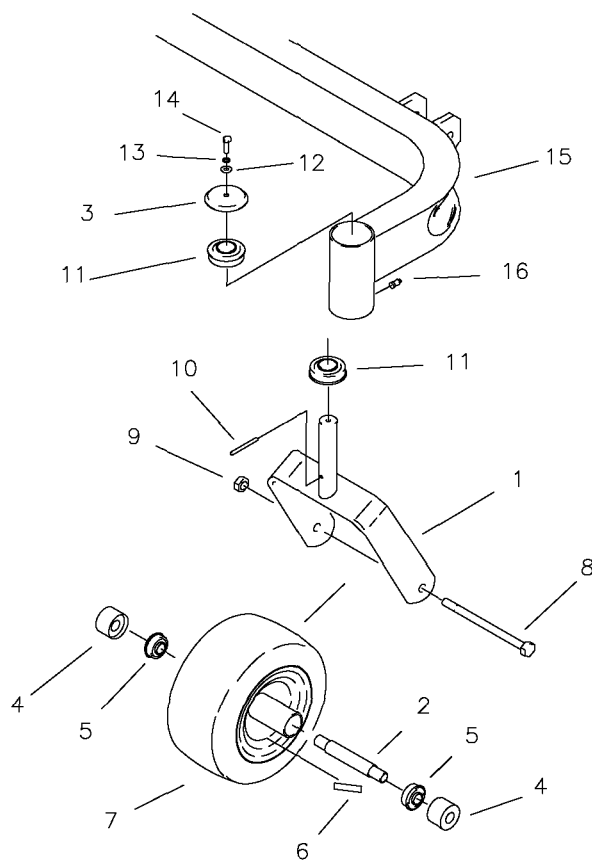

REF NO.	PART NO.	QTY.	DESCRIPTION
1	659-003W	2	CASTER WELDMENT FOR JAZEE
-	617-355W	2	CASTER WELDMENT FOR JAZEE PRO
2	622-121P	2	BEARING SPACER
-	611-136P	-	BEARING SPACER, JAZEE PRO
3	636-176P	2	BEARING CAP, RED
4	659-004P	4	BEARING SHIELD
-	611-135P	-	BEARING SHIELD, JAZEE PRO
5	D-3432	4	BEARING, 5/8 ID X 1-3/8 OD
6	P-11384	2	DECAL, 12 PSI
7	D-3605	2	10" TIRE, W/RIM
-	D-3574	-	TIRE, 13" W/ WHEEL, JAZEE PRO
8	F-1942	2	1/2-13 X 6 1/2" GR. 5 BOLT
9	F-1005-05	2	1/2-13 LOCK NUT
10	F-1456	2	3/16" X 2" ROLL PIN
11	D-2008-02	4	BEARING, SPD SF-16-32
12	F-1009-01	2	1/4" FLAT WASHER
13	F-1019-01	2	1/4" LOCK WASHER
14	F-1810	2	1/4-20 X 3/4 W/NYLON PATCH
15	659-038W	1	FRONT AXLE WELDMENT FOR JAZEE
-	663-003W	1	FRONT AXLE WELDMENT FOR JAZEE PRO
16	H-1056	2	GREASE ZERK

# FRAME SIDES & RELATED PARTS FOR JAZEE SR205

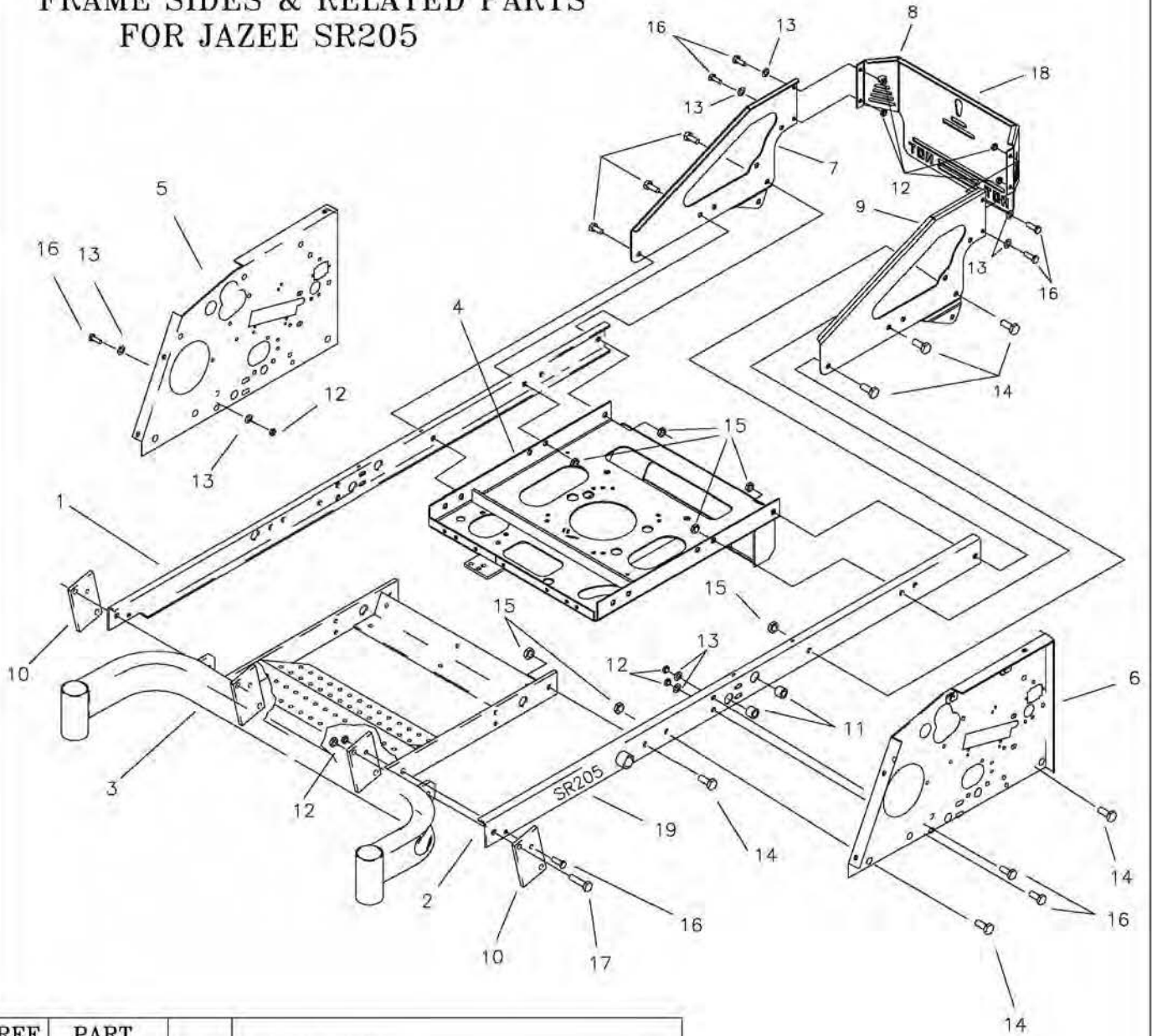

REF NO.	PART NO.	QTY.	DESCRIPTION
1	659-021W	1	FRAME SIDE RH.
2	659-022W	1	FRAME SIDE LH.
3	659-038W	1	AXLE MOUNTING WLDT.
4	659-174W	1	MOTOR MOUNT WLDT.
5	659-011P	1	SIDE PANEL RH.
6	659-012P	1	SIDE PANEL LH.
7	659-133P	1	ENGINE GUARD RH SIDE PANEL
8	647-123A	1	TWIN CYLINDER REAR PANEL GUARD W/ DECAL
-	659-164A	1	SINGLE CYLINDER REAR PANEL GUARD W/ DECAL
9	659-134P	1	ENGINE GUARD LH SIDE PANEL
10	642-063P	4	DRAG BAR TAB
11	D-3730	4	BUSHING, 5/8 BORE(JOYSTICK)
12	F-1005-03	10	3/8-16 STOVER NUT
13	F-1009-03	10	3/8 FLAT WASHER
14	F-1759	8	1/2-13 X 1" GR.5
15	F-1005-05	16	1/2-13 LOCK NUT
16	F-1558	6	3/8-16 X 7/8" GR.5
17	F-1293	2	1/2-13 X 2", GR.5
18	P-12097	1	COLORS DECAL, "COUNTRY CLIPPER"
19	P-12186	2	DECAL, "SR205" SERIES MOWER

FRAME SIDES &  
RELATED PARTS  
FOR JAZEE PRO SR355

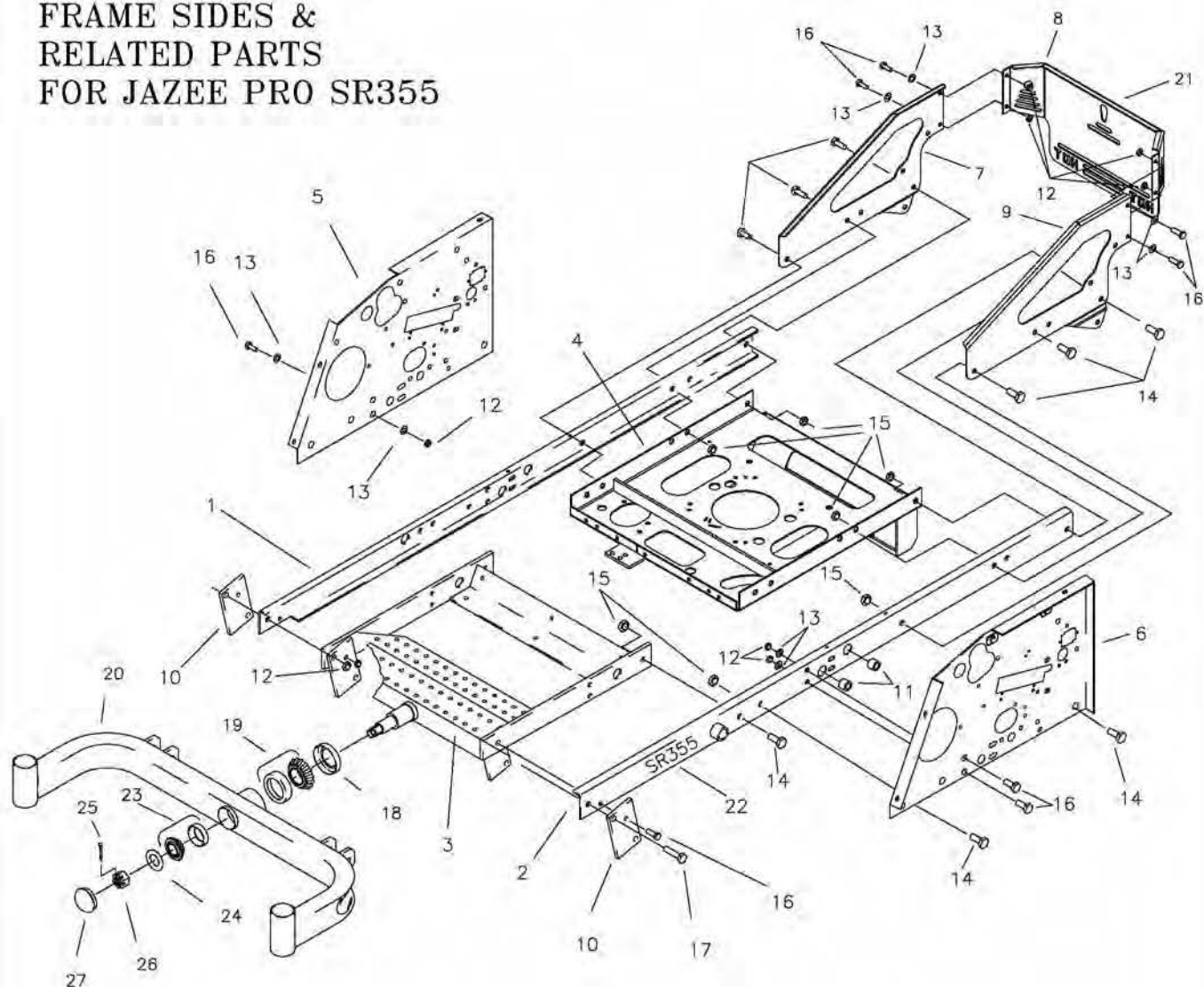

REF NO.	PART NO.	QTY.	DESCRIPTION	REF NO.	PART NO.	QTY.	DESCRIPTION
1	659-021W	1	FRAME SIDE RH.	15	F-1005-05	12	1/2-13 LOCK NUT
2	659-022W	1	FRAME SIDE LH.	16	F-1558	10	3/8-16 X 7/8" GR.5
3	659-123W	1	AXLE MOUNTING WLDT.	17	F-1293	2	1/2-13 X 2", GR.5
4	659-174W	1	MOTOR MOUNT WLDT.	18	D-3647	1	FRONT PIVOT SEAL
5	659-011P	1	SIDE PANEL RH.	19	D-3646	1	FRONT PIVOT TAPARED ROLLER BRG.
6	659-012P	1	SIDE PANEL LH.	20	663-003W	1	FRONT AXLE WELDMENT
7	659-133P	1	ENGINE GUARD RH SIDE PANEL	21	P-12097	1	COLORDED DECAL, "COUNTRY CLIPPER"
8	647-123A	1	TWIN CYL. REAR PANEL GUARD W/DECAL	22	P-12187	2	DECAL, "SR355" SERIES MOWER
—	659-164A	1	SINGLE CYL. REAR PANEL GUARD W/DECAL	23	D-3782	1	TAPARED ROLLER BRG.
9	659-134P	1	ENGINE GUARD LH SIDE PANEL	24	606-303P	1	1" WASHER
10	642-063P	2	DRAG BAR TAB	25	F-1728	1	3/16 X 2" COTTER PIN
11	D-3730	2	BUSHING, 5/8 BORE(JOYSTICK)	26	F-1724	1	1-14 SLOTTED NUT
12	F-1005-03	10	3/8-16 STOVER NUT	27	H-1924	1	GREASE CAP
13	F-1009-03	10	3/8 FLAT WASHER				
14	F-1759	12	1/2-13 X 1" GR.5				

# FENDER ASSEMBLY

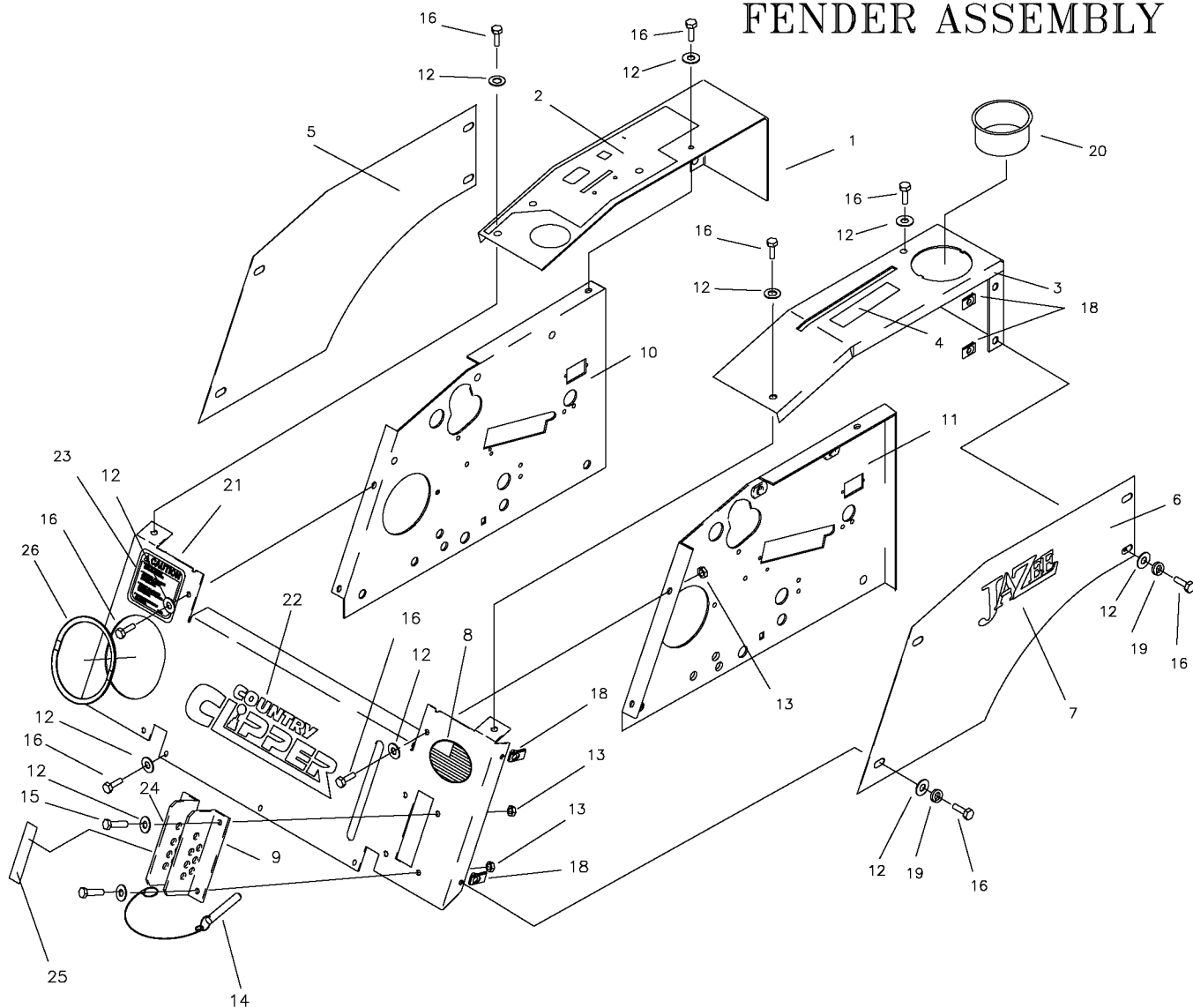

REF NO.	PART NO.	QTY.	DESCRIPTION	REF NO.	PART NO.	QTY.	DESCRIPTION
1	659-067A	1	FENDER CAP RH W/DECAL	13	F-1125	16	5/16-18 LOCK NUT
-	659-098A	1	FENDER CAP, TWIN STK. RH W/DECAL	14	F-1807	1	1/2" X 2.4 CLEVIS PIN W/SASH
2	P-11626	1	DECAL, "CONTROL PANEL"	15	F-1879	3	5/16-18 X 1-1/4" GR. 5
3	659-068A	1	FENDER CAP LH. W/DECAL	16	F-1015-15	21	5/16-18 X 1" GR.5
-	659-097A	1	FENDER CAP, TWIN STK. LH. W/DECAL	18	F-1860	8	5/16 U-NUT
4	P-11382	1	DECAL, PARK BRAKE	19	F-1019-02	8	5/16 LOCK WASHER
5	659-069A	1	FENDER SKIRT RH W/DECAL	20	644-028P	1	CUP HOLDER
-	659-141A	1	FENDER SKIRT RH JAZEE PRO W/DECAL	21	659-071A	1	FRONT PANEL W/DECALS
6	659-070A	1	FENDER SKIRT LH W/DECAL	22	P-12097	1	DECAL, "COUNTRY CLIPPER"
-	659-142A	1	FENDER SKIRT LH JAZEE PRO W/DECAL	23	P-10939	1	DECAL, "CAUTION"
7	P-11624	2	DECAL, JAZEE	24	642-137A	1	LATCH PLATE RH W/DECAL
-	P-12063	2	DECAL, JAZEE PRO	25	P-11407	1	DECAL, "CUT HEIGHT"
8	P-12253	1	MADE IN THE USA DECAL	26	H-1626	1	"U"-CHANNEL TRIM
9	642-131P	1	LATCH PLATE LH.				
10	659-011P	1	SIDE PANEL RH.				
11	659-012P	1	SIDE PANEL LH.				
12	F-1009-02	22	5/16 FLAT WASHER				

# SEAT, FOOTDECK & RELATED PARTS

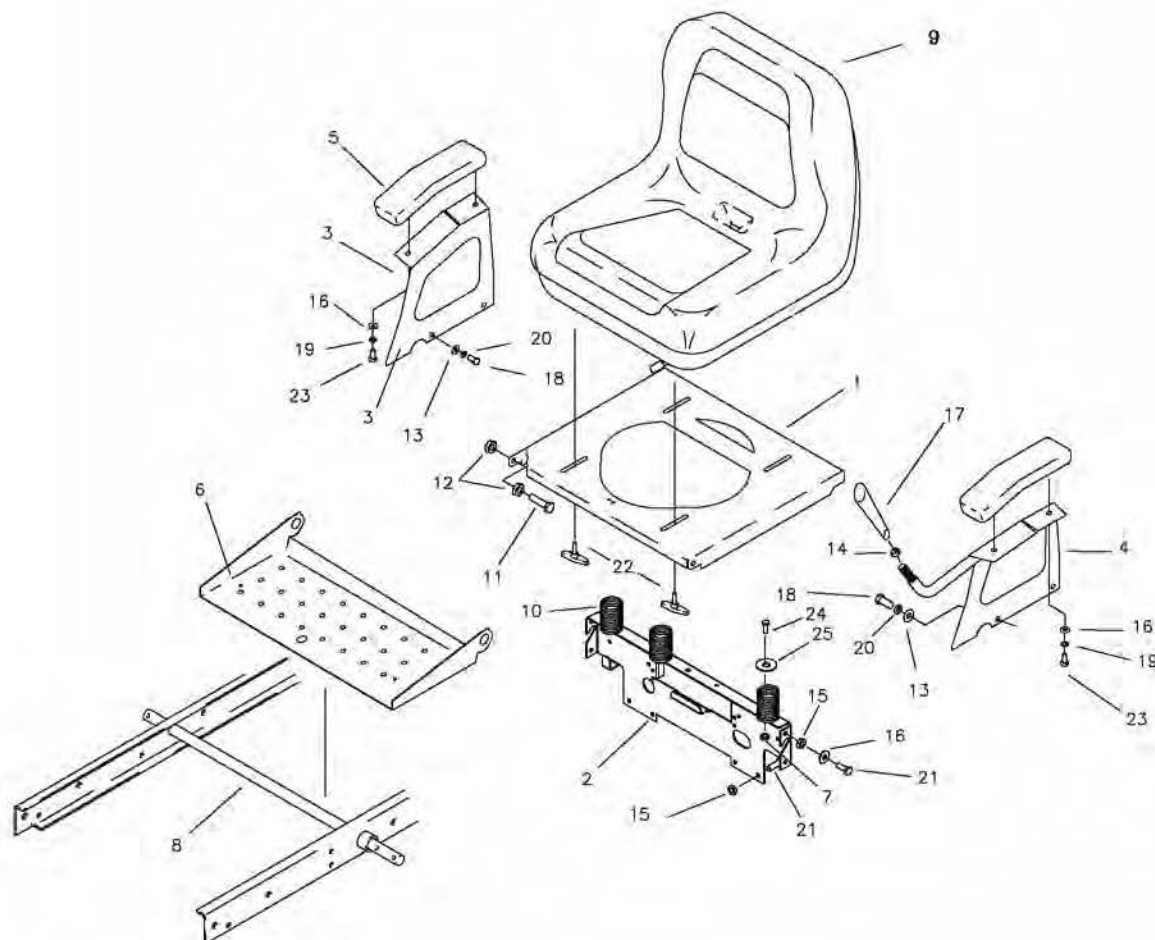

REF NO.	PART NO.	QTY.	DESCRIPTION	REF NO.	PART NO.	QTY.	DESCRIPTION
1	659-005P	1	SEAT MOUNTING BASE	15	F-1125	8	5/16-18 LOCK NUT
2	659-016P	1	REAR SEAT BRACE	16	F-1009-02	8	5/16 FLAT WASHER
3	659-051P	1	ARM REST RH. (JOYSTICK)	17	H-2317	1	TAPERED HANDLE
4	659-055W	1	ARM REST LH. (JOYSTICK)	18	F-1015-23	4	3/8-16 X 3/4" GR. 5
—	636-163P	1	ARM REST LH. (TWINSTICK)	19	F-1019-02	4	5/16 LOCK WASHER
5	621-143A	2	ARM REST PAD	20	F-1019-03	4	3/8 LOCK WASHER
6	659-072A	1	FOOT DECK W/TREAD	21	F-1546	6	5/16-18 X 3/4" GR. 5
7	H-1931	2	SAFETY TREAD	22	659-073A	4	T-HANDLE ASSEMBLY
8	620-051P	1	LIFT BAR	23	F-1015-15	4	5/16-18 X 1" GR. 5
9	H-2393	1	SEAT	24	F-1538	3	1/4-20 X 3/4", GR.5
10	H-1920	3	SEAT SPRING	25	620-050P	3	1" HEAVY WASHER
11	F-1015-27	2	3/8-16 X 1 1/2" GR. 5				
12	F-1005-03	2	3/8-16 LOCK NUT				
13	F-1009-03	4	3/8 FLAT WASHER				
14	F-1486	1	3/8-16 JAM NUT				

# FUEL TANK ASSEMBLY

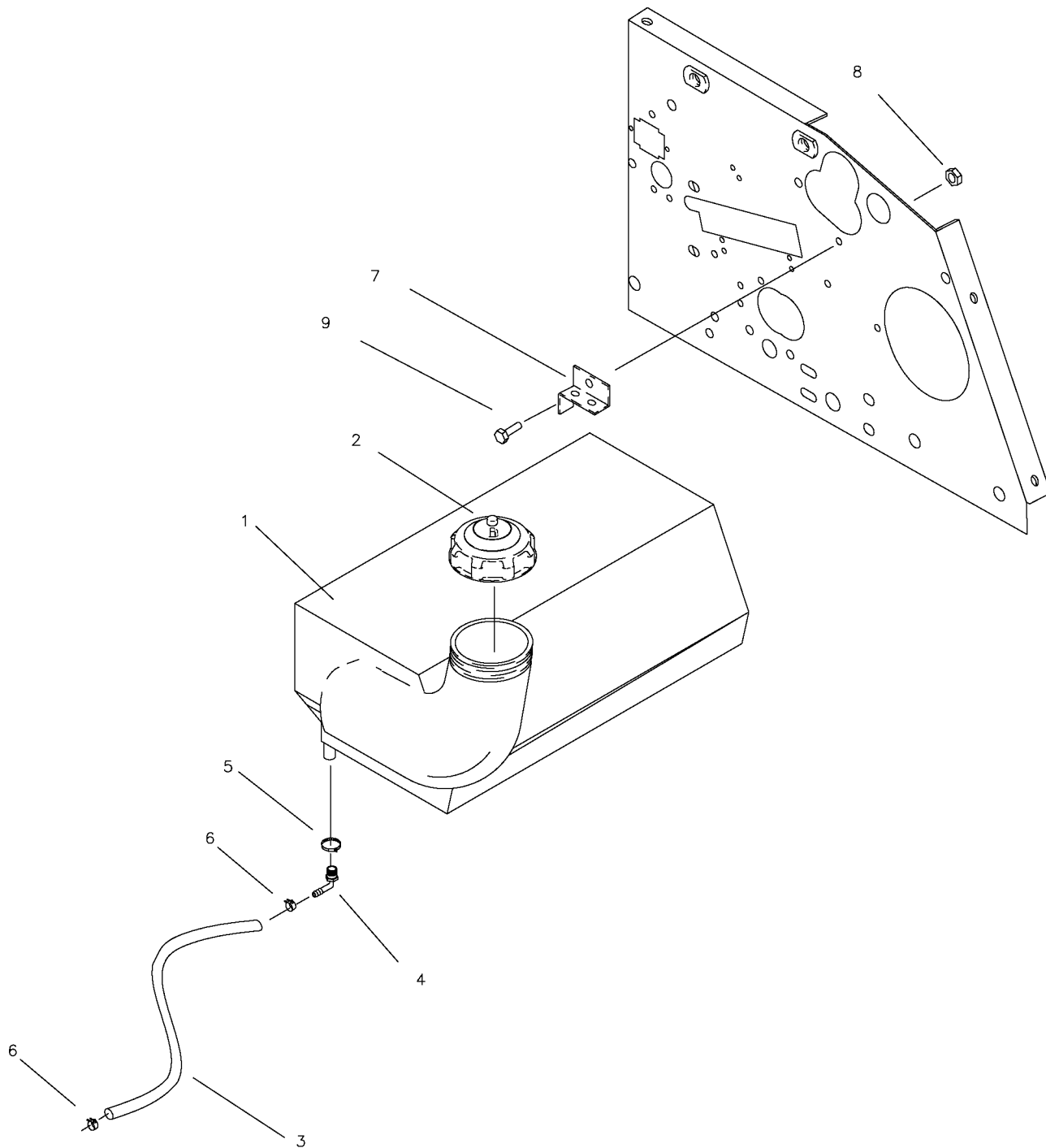

REF NO.	PART NO.	QTY.	DESCRIPTION
1	H-2394	1	4 1/2 GALLON TANK
2	H-2232	1	GAS CAP
3	644-034P	1	29-1/2" FUEL LINE
4	H-1646	1	HOSE BARB, 90 DEG.
5	H-1952	1	HOSE CLAMP
6	H-1687	2	HOSE CLAMP, 1/2"
7	659-066P	1	TANK MOUNTING CLAMP
8	F-1158	1	1/4-20 STOVER NUT
9	F-1015-03	1	1/4-20 X 3/4, GR.5

# JOYSTICK STEERING CONTROL AND RELATED PARTS

NOTE; ITEM'S #2 AND #3 MUST BE REPLACED AT THE SAME TIME FOR MAXIMUM PERFORMANCE.

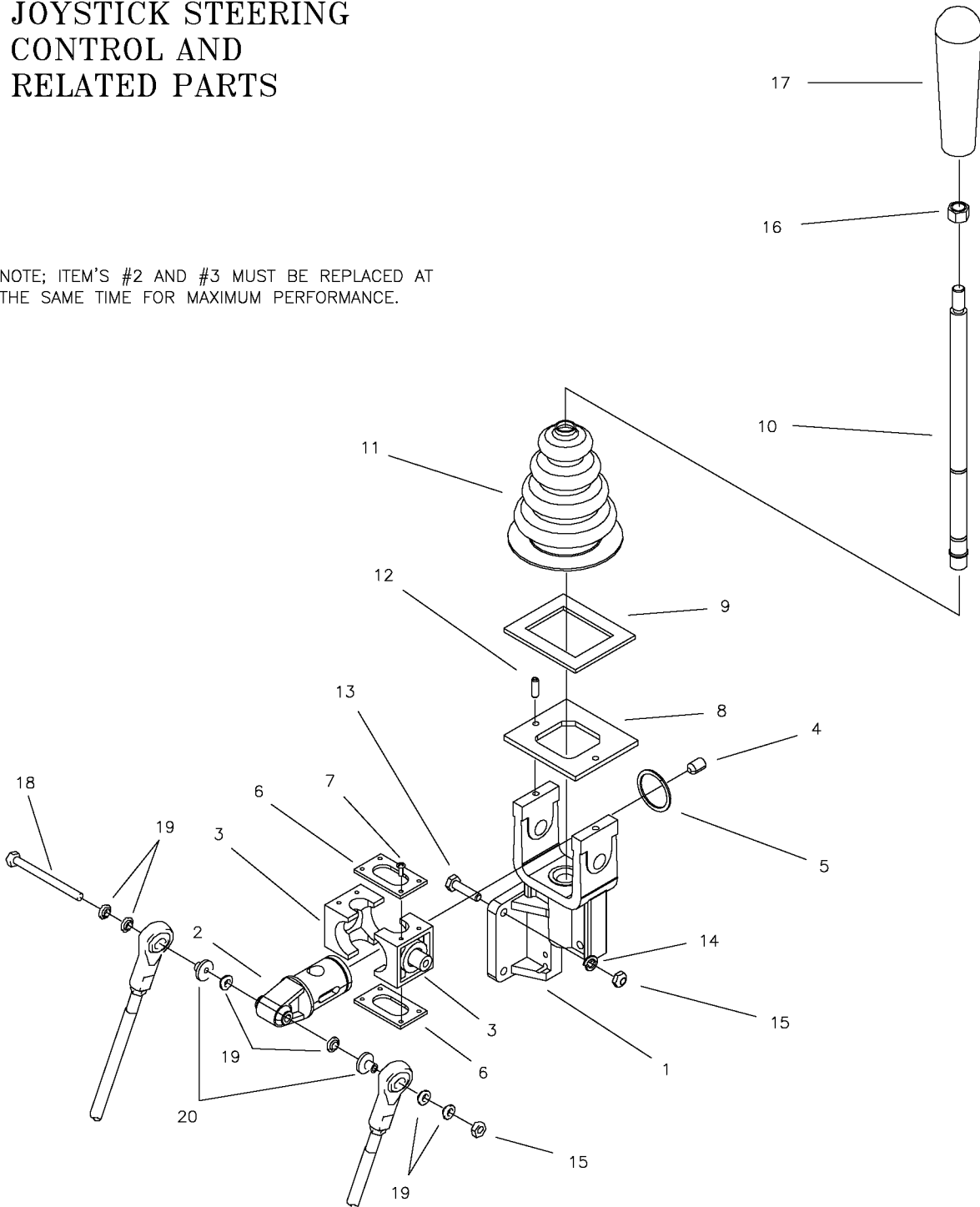

REF NO.	PART NO.	QTY.	DESCRIPTION	REF NO.	PART NO.	QTY.	DESCRIPTION
-	647-122A	1	JOYSTICK ASSEMBLY	11	H-1991	1	BOOT, BELLOWS
1	659-144P	1	JOYSTICK YOKE	12	F-1999	2	ROLL PIN, 3/16 X 5/8
2	H-1992	1	PIVOT SHAFT	13	F-1015-05	3	1/4-20 X 1" HHCS GR. 5
3	H-1993	2	PIVOT BLOCK	14	F-1019-01	3	1/4" LOCK WASHER
4	F-1120	1	BALL PLUNGER	15	F-1158	4	1/4-20 LOCK NUT
5	H-1997	1	SNAP RING, SPIRLOCK	16	F-1011-03	1	3/8-16 NUT, JAM
6	619-306P	2	PIVOT BLOCK PLATE	17	H-2317	1	GRIP, HANDLE
7	F-1624	8	#6-32 X 3/8" SCREW SLOT	18	F-1020-01	1	1/2-20 X 3-1/2" GR. 5
8	659-129P	1	JOYSTICK TOP PLATE	19	H-1989	6	BUSHING, BALL JOINT
9	H-1947	1	GASKET, FOAM	20	H-2465	2	1/4" SPACER
10	621-140A	1	JOYSTICK SHAFT ASSEMBLY				

## JOYSTICK STEERING CONTROL AND RELATED PARTS FOR JAZEE SR205

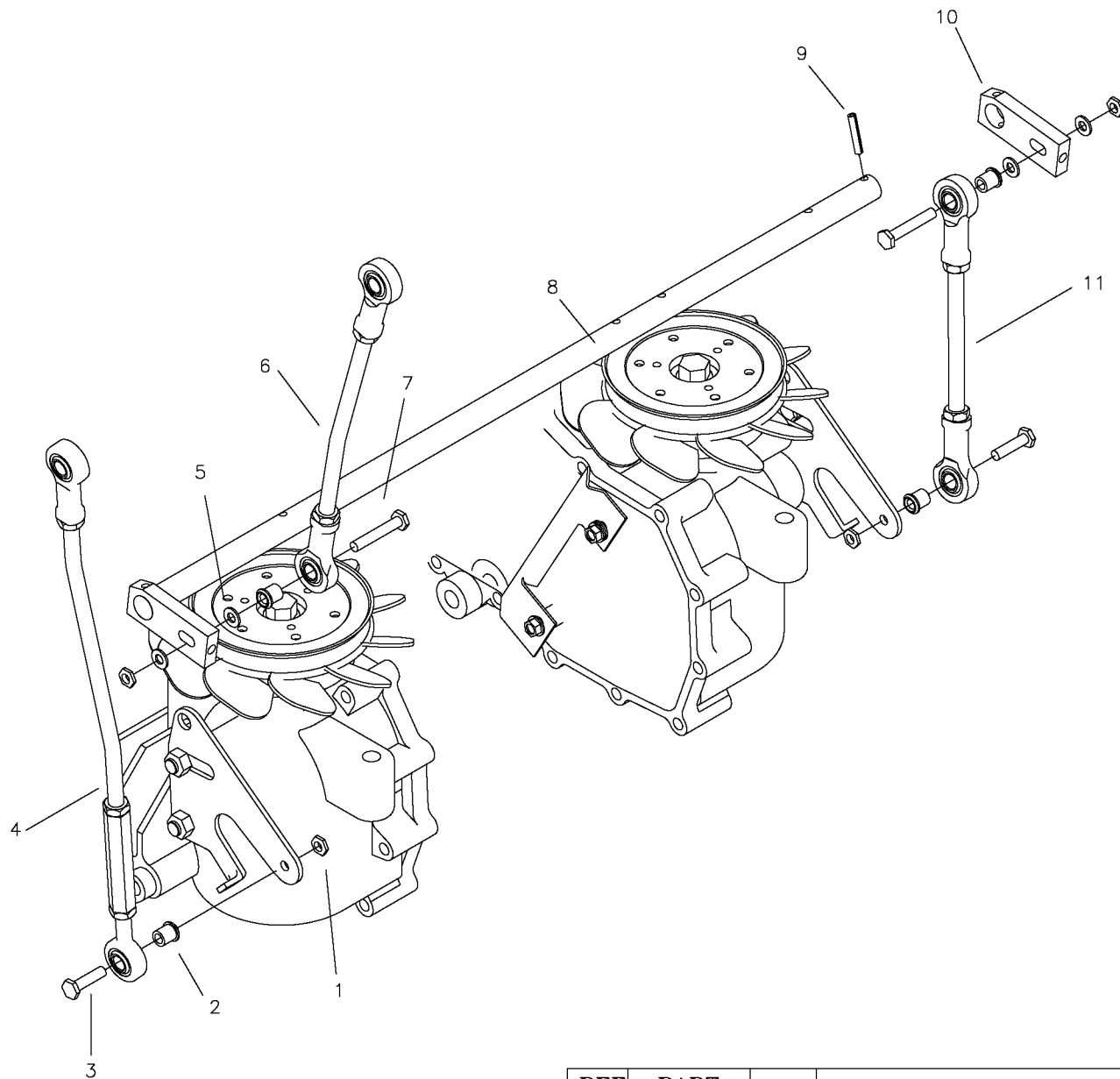

REF NO.	PART NO.	QTY.	DESCRIPTION
1	F-1158	4	1/4-20 LOCK NUT
2	H-2465	4	1/2 X 1/4" SHOULDERWASHER
3	F-1015-05	2	1/4-20 X 1"
4	663-050P	1	STEERING LINKAGE
5	F-1009-02	4	1/4" FLAT WASHER
6	663-049P	1	UPPER STEERING LINKAGE
7	F-1716	2	1/4-20 X 1 1/2"
8	659-026P	2	HYDRO SHAFT ROD
9	F-1503	2	ROLL PIN 3/16 X 1"
10	625-030P	2	SWIVEL ARM
11	659-127P	1	LOWER STEERING LINKAGE



## JOYSTICK STEERING CONTROL AND RELATED PARTS FOR JAZEE PRO SR355

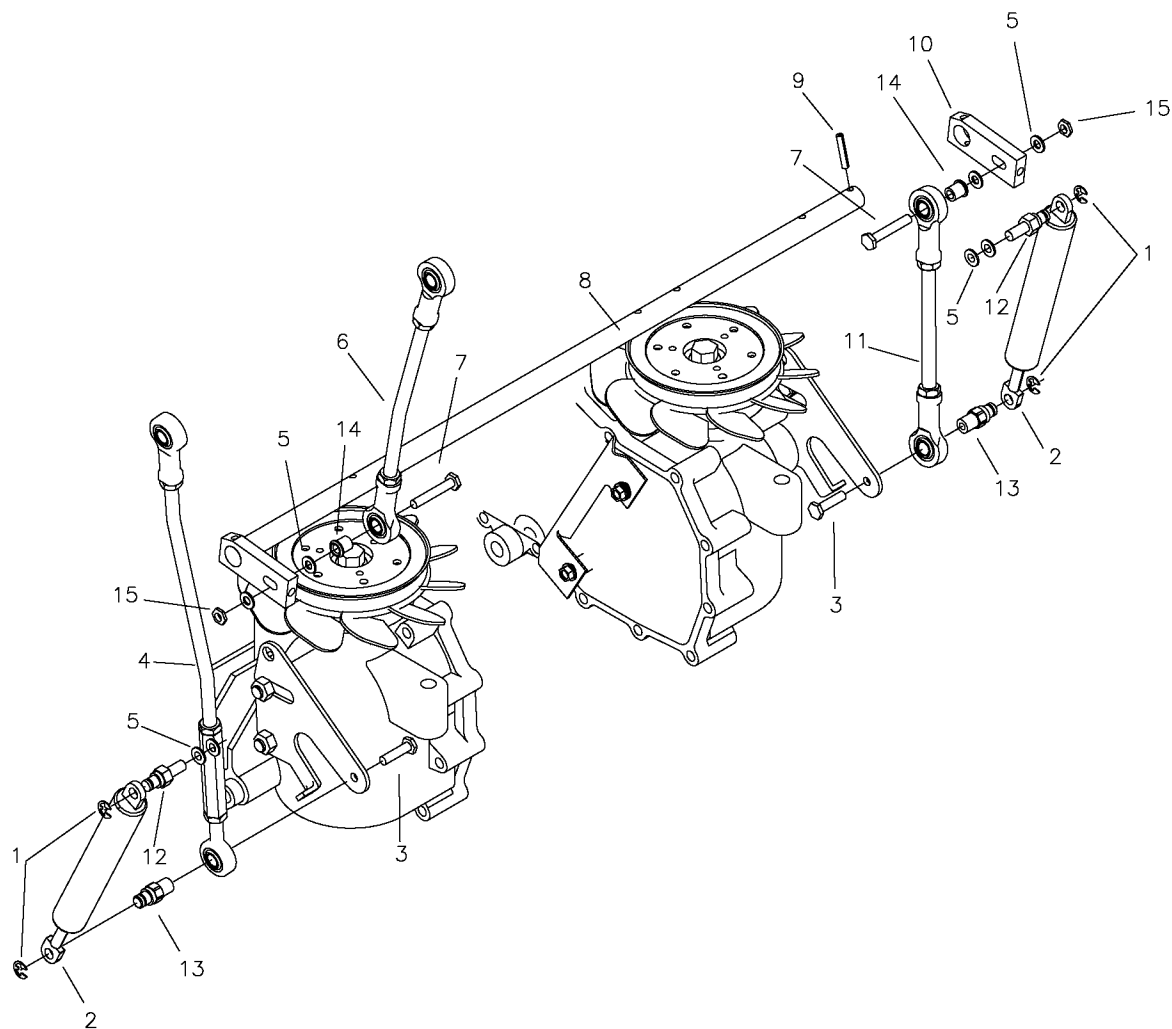

REF NO.	PART NO.	QTY.	DESCRIPTION
1	F-1610	4	RETAINING RING, INTERNAL
2	H-2467	2	DUAL ACTION DAMPER
3	F-1015-03	2	1/4-20 X 1"
4	663-050P	1	STEERING LINKAGE
5	F-1009-02	8	1/4" FLAT WASHER
6	663-049P	1	UPPER STEERING LINKAGE
7	F-1716	2	1/4-20 X 1 1/2"
8	659-026P	2	HYDRO SHAFT ROD
9	F-1503	2	ROLL PIN 3/16 X 1"
10	625-030P	2	SWIVEL ARM
11	659-127P	1	LOWER STEERING LINKAGE
12	638-028P	2	DAMPER BOLT, 5/16-18 X 3/4"
13	663-051P	2	DAMPER STUD, FEMALE
14	H-2465	2	1/2 X 1/4" SHOULDER WASHER
15	F-1158	2	1/4" STOVER LOCK NUT

## RIGHT HAND STEERING CONTROL AND RELATED PARTS

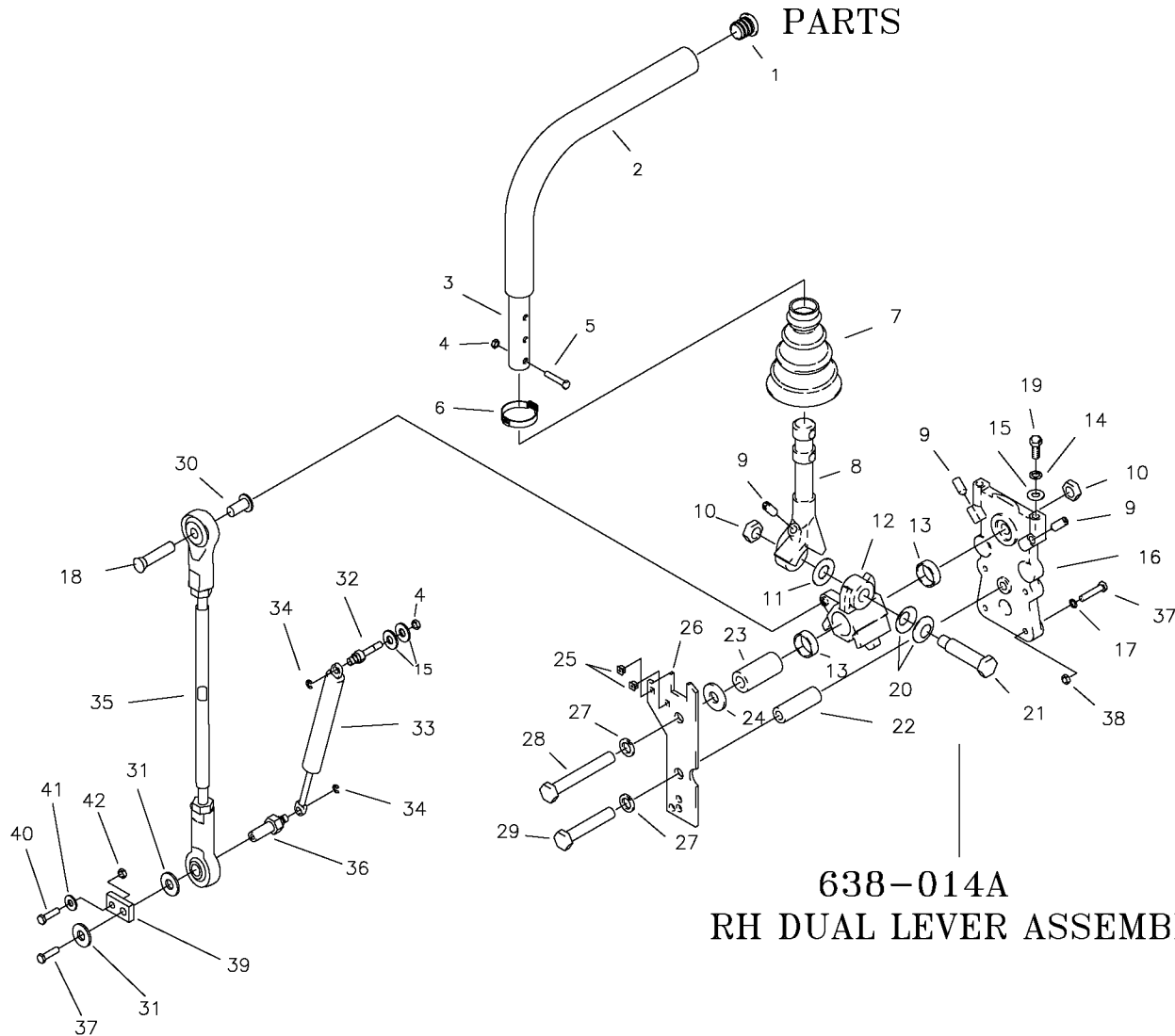

**638-014A  
RH DUAL LEVER ASSEMBLY**

REF NO.	PART NO.	QTY.	DESCRIPTION	REF NO.	PART NO.	QTY.	DESCRIPTION
1	H-2080	1	END PLUG, 15/16" BLACK	23	625-064P	1	BUSHING, PIVOT BLOCK
2	H-2079	1	FOAM GRIP, 17"	24	625-072P	1	WASHER, FLAT
3	642-004A	1	CONTROL LEVER ASSEMBLY	25	F-1995	2	GROMMET, NYLON
4	F-1125	3	5/16 LOCK NUT	26	636-167P	1	TOP PLATE, DUALEVER
5	F-1015-17	2	5/16-18 X 1-1/2" HHCS GR. 5	27	F-1464	2	1/2" LOCK WASHER
6	H-2089	1	HOSE CLAMP	28	F-1828	1	1/2-13 X 3-1/2" HHCS GR. 5
7	H-2081	1	BOOT, TAPERED 1" CUFF	29	F-1439	1	1/2-13 X 3" HHCS GR. 5
8	625-063P	1	LEVER, DUALEVER	30	H-2465	1	1/2 X 1/4" SHOULDER WASHER
9	F-1842	3	SETSCREW, 5/16-18 X 3/4"	31	F-1009-01	2	1/4" FLAT WASHER
10	F-1489	2	1/2-13 JAM NUT	32	638-028P	1	DAMPER BOLT, 5/16-18 X 3/4"
11	H-2116	1	WASHER, FIBER	33	H-2168	1	STEERING DAMPER
12	638-033P	1	PIVOT BLOCK, DUALEVER	34	F-1610	2	E-RING FOR 1/4" SHAFT
13	D-3622	2	BEARING	35	663-050P	1	LINK ROD ASSEMBLY
14	F-1019-02	2	5/16" LOCK WASHER	36	663-051P	1	DAMPER BOLT, 1/4-20 FEMALE
15	F-1009-02	4	WASHER, FLAT STD. 5/16"	37	F-1539	4	1/4-20 X 1-1/4" HHCS GR. 5
16	638-034P	1	BASE DUALEVER	38	F-1158	3	1/4-20 LOCK NUT
17	F-1019-01	11	1/4" LOCK WASHER	39	659-180P	1	TRACKING ADJUSTMENT ADAPTER
18	F-1974	1	1/4-20 X 1-1/4" SOCK HD	40	F-1015-23	1	3/8-16 X 3/4" CAPSCREW
19	F-1546	1	5/16-18 X 3/4" HHCS GR. 5	41	F-1009-03	1	3/8" FLAT WASHER
20	H-2115	2	WASHER, SPRING	42	F-1005-03	1	3/8-16 LOCK NUT
21	625-070P	1	SHOULDER BOLT, 5/8" OD				
22	625-067P	1	BUSHING, STAND OFF				

# LEFT HAND STEERING CONTROL AND RELATED PARTS

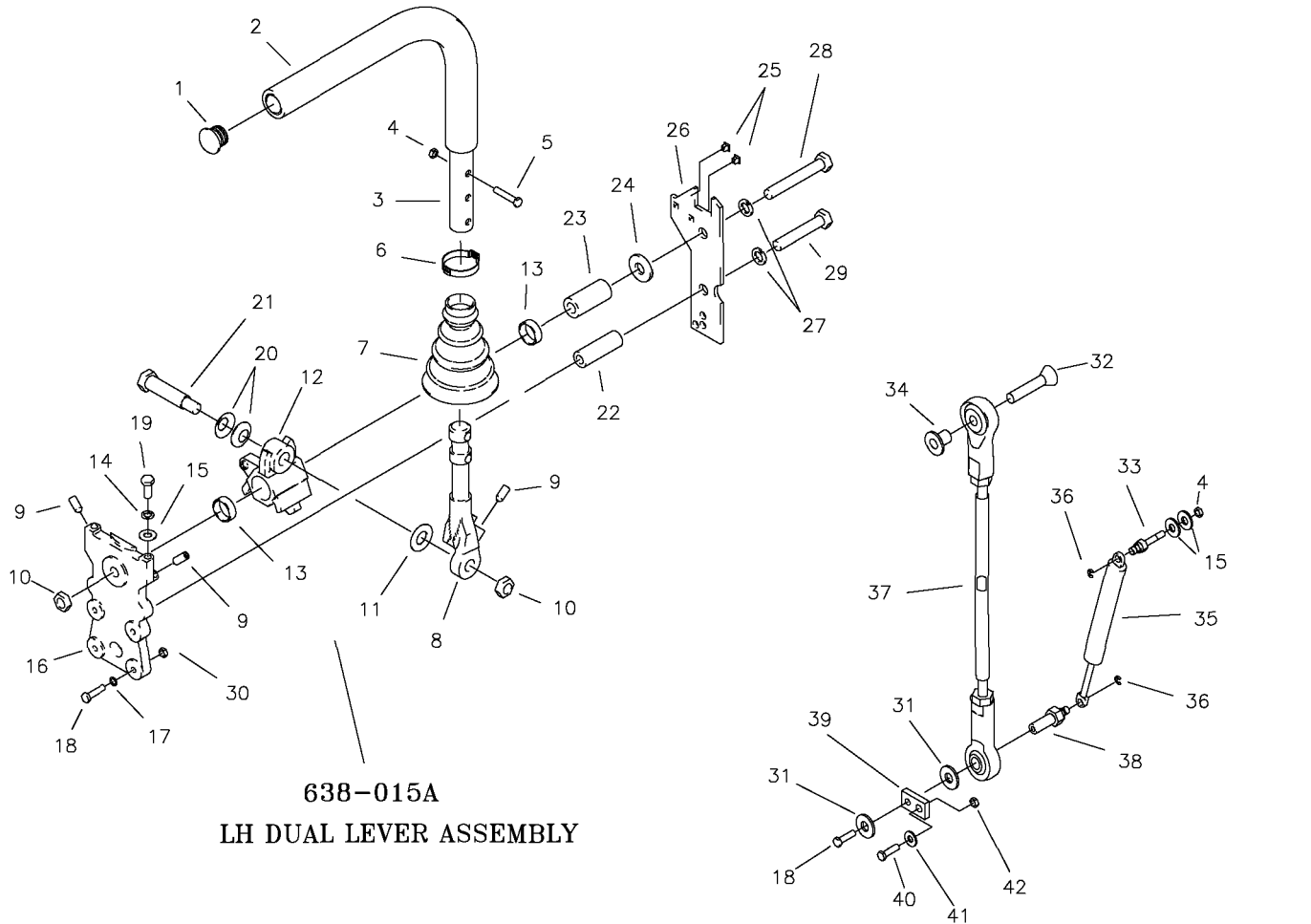

REF NO.	PART NO.	QTY.	DESCRIPTION	REF NO.	PART NO.	QTY.	DESCRIPTION
1	H-2080	1	END PLUG, 15/16" BLACK	22	625-067P	1	BUSHING, STAND OFF
2	H-2079	1	FOAM GRIP, 17"	23	625-064P	1	BUSHING, PIVOT BLOCK
3	642-004A	1	CONTROL LEVER ASSEMBLY	24	625-072P	1	WASHER, FLAT
4	F-1125	3	5/16 LOCK NUT	25	F-1995	2	GROMMET, NYLON
5	F-1015-17	2	5/16-18 X 1-1/2" HHCS GR. 5	26	636-167P	1	TOP PLATE, DUALEVER
6	H-2089	1	HOSE CLAMP	27	F-1464	2	1/2" LOCK WASHER
7	H-2081	1	BOOT, TAPERED 1" CUFF	28	F-1828	1	1/2-13 X 3-1/2" HHCS GR. 5
8	625-063P	1	LEVER, DUALEVER	29	F-1439	1	1/2-13 X 3" HHCS GR. 5
9	F-1842	3	SETSCREW, 5/16-18 X 3/4"	30	F-1158	3	1/4-20 LOCK NUT
10	F-1489	2	1/2-13 JAM NUT	31	F-1009-01	2	1/4" FLAT WASHER
11	H-2116	1	WASHER, FIBER	32	F-1974	1	1/4-20 X 1-1/4" SOCKHEAD BOLT
12	638-033P	1	PIVOT BLOCK, DUALEVER	33	638-028P	2	DAMPER BOLT, 5/16-18 X 3/4"
13	D-3622	2	BEARING	34	H-2465	1	SHOULDER WASHER
14	F-1019-02	3	5/16" LOCK WASHER	35	H-2168	1	STEERING DAMPER
15	F-1009-02	5	WASHER, FLAT STD. 5/16"	36	F-1610	2	E-RING FOR 1/4" SHAFT
16	638-034P	1	BASE DUALEVER	37	663-050P	1	STEERING LINKAGE
17	F-1019-01	11	1/4" LOCK WASHER	38	663-051P	1	DAMPER BOLT, 1/4-20 FEMALE
18	F-1539	4	1/4-20 X 1-1/4" HHCS GR. 5	39	659-180P	1	TRACKING ADJUSTMENT ADAPTER
19	F-1546	1	5/16-18 X 3/4" HHCS GR. 5	40	F-1015-23	1	3/8-16 X 3/4" CAPSCREW
20	H-2115	2	WASHER, SPRING	41	F-1009-03	1	3/8 FLAT WASHER
21	625-070P	1	SHOULDER BOLT, 5/8" OD	42	F-1005-03	1	3/8-16 LOCK NUT

# PARKING BRAKE ASSEMBLY & RELATED PARTS FOR JAZEE SR205

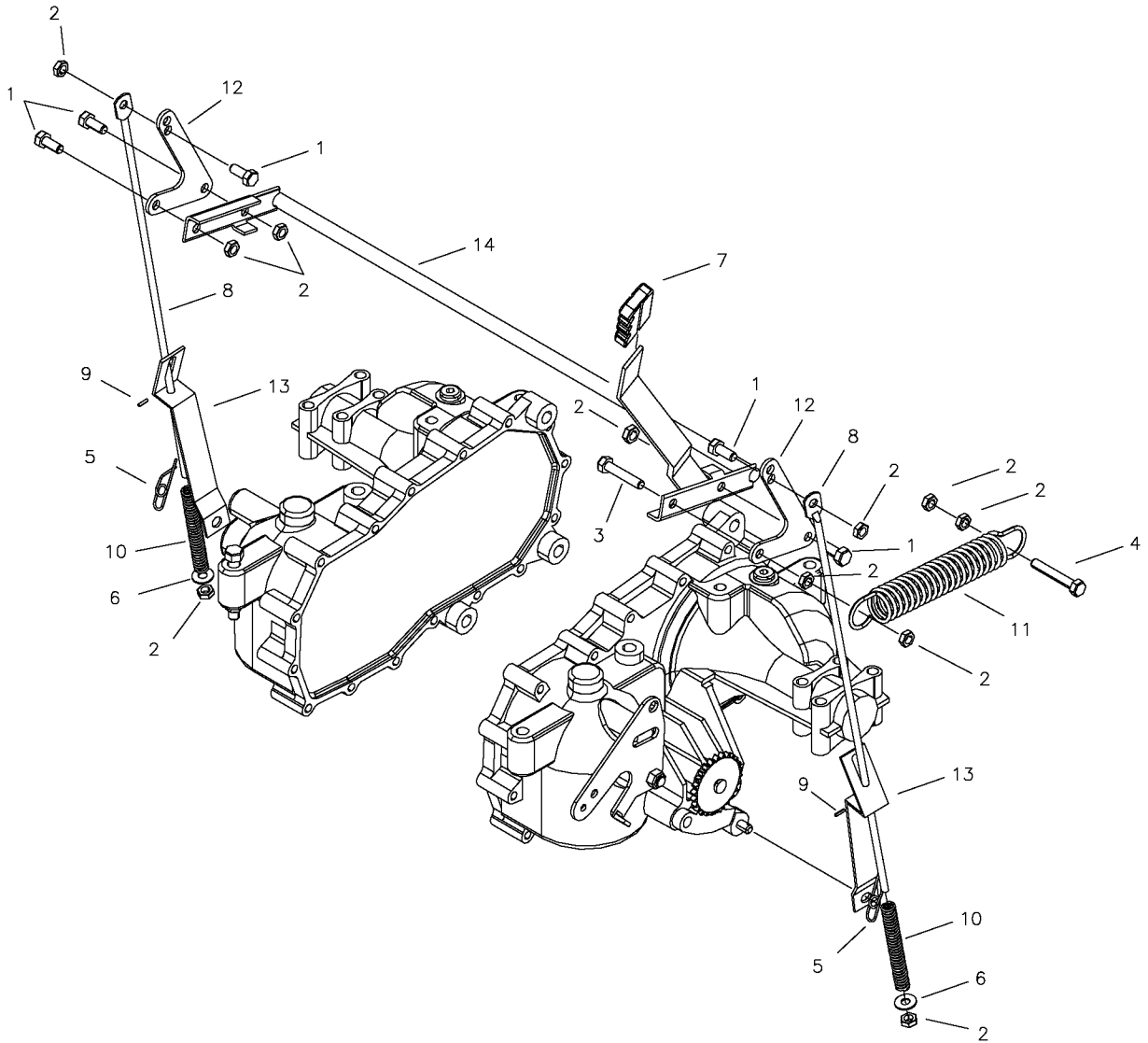

REF NO.	PART NO.	QTY.	DESCRIPTION
1	F-1546	5	5/16-18 X 3/4" GR. 5
2	F-1125	11	5/16" STOVER LOCK NUT
3	F-1015-17	1	5/16-18 X 1-1/2" GR. 5
4	F-1015-19	1	5/16-18 X 2" GR. 5
5	F-1492	2	RUE RING, 5/16-3/8 PIN
6	F-1009-02	2	5/16" FLAT WASHER
7	H-1926	1	GRIP, HANDLE, 1/4" X 1"
8	H-2206	2	BRAKE LINK ROD
9	H-1800	2	ROLL PIN 3/32 OD X 3/8 LONG
10	H-2426	2	SPRING, 3.69 X .372 ID X .064
11	H-1635	1	SPRING, EXT. 3/4 X 4" OAL
12	659-143P	1	SHIFT PLATE
13	659-013P	2	LOWER BRAKE LINK
14	659-010W	1	BRAKE ROD WELDMENT

# PARKING BRAKE ASSEMBLY & RELATED PARTS FOR JAZEE PRO SR355

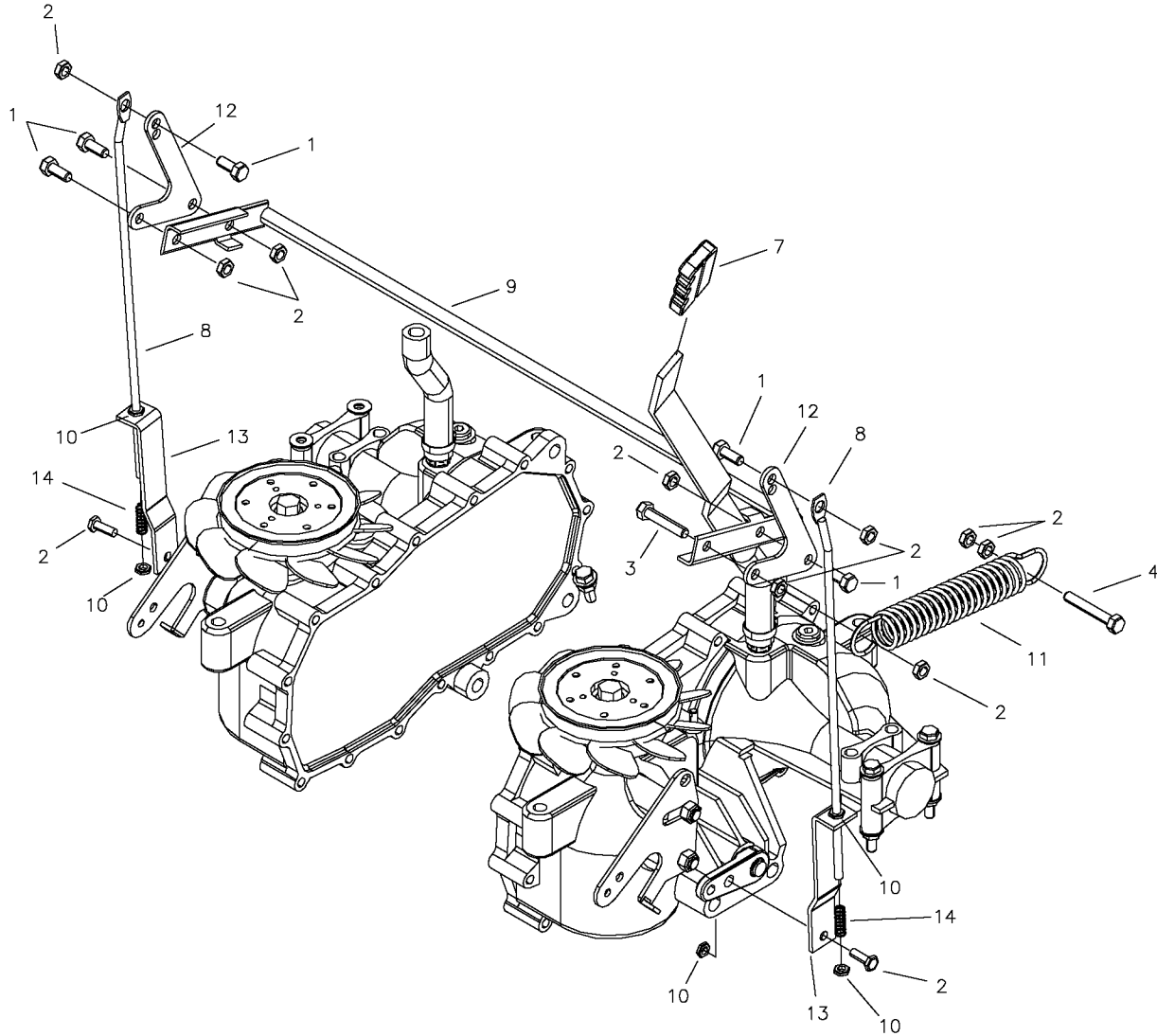

REF NO.	PART NO.	QTY.	DESCRIPTION
1	F-1546	5	5/16-18 X 3/4" GR. 5
2	F-1125	9	5/16" STOVER LOCK NUT
3	F-1015-17	1	5/16-18 X 1-1/2" GR. 5
4	F-1015-19	1	5/16-18 X 2" GR. 5
5	F-1492	2	RUE RING, 5/16-3/8 PIN
6	F-1015-03	2	1/4-20 X 3/4" GR. 5
7	H-1926	1	GRIP, HANDLE, 1/4" X 1"
8	H-2452	2	BRAKE LINK BAR, BENT
9	659-010W	1	BRAKE ROD WELDMENT
10	F-1158	6	1/4" STOVER LOCK NUT
11	H-1635	1	SPRING, EXT. 3/4 X 4" OAL
12	659-143P	1	SHIFT PLATE
13	659-159P	2	LOWER BRAKE LINK
14	H-1637	2	COMPRESSION SPRING

# MOTOR AND TRANSMISSION ASSEMBLY & RELATED PARTS FOR JAZEE SR205

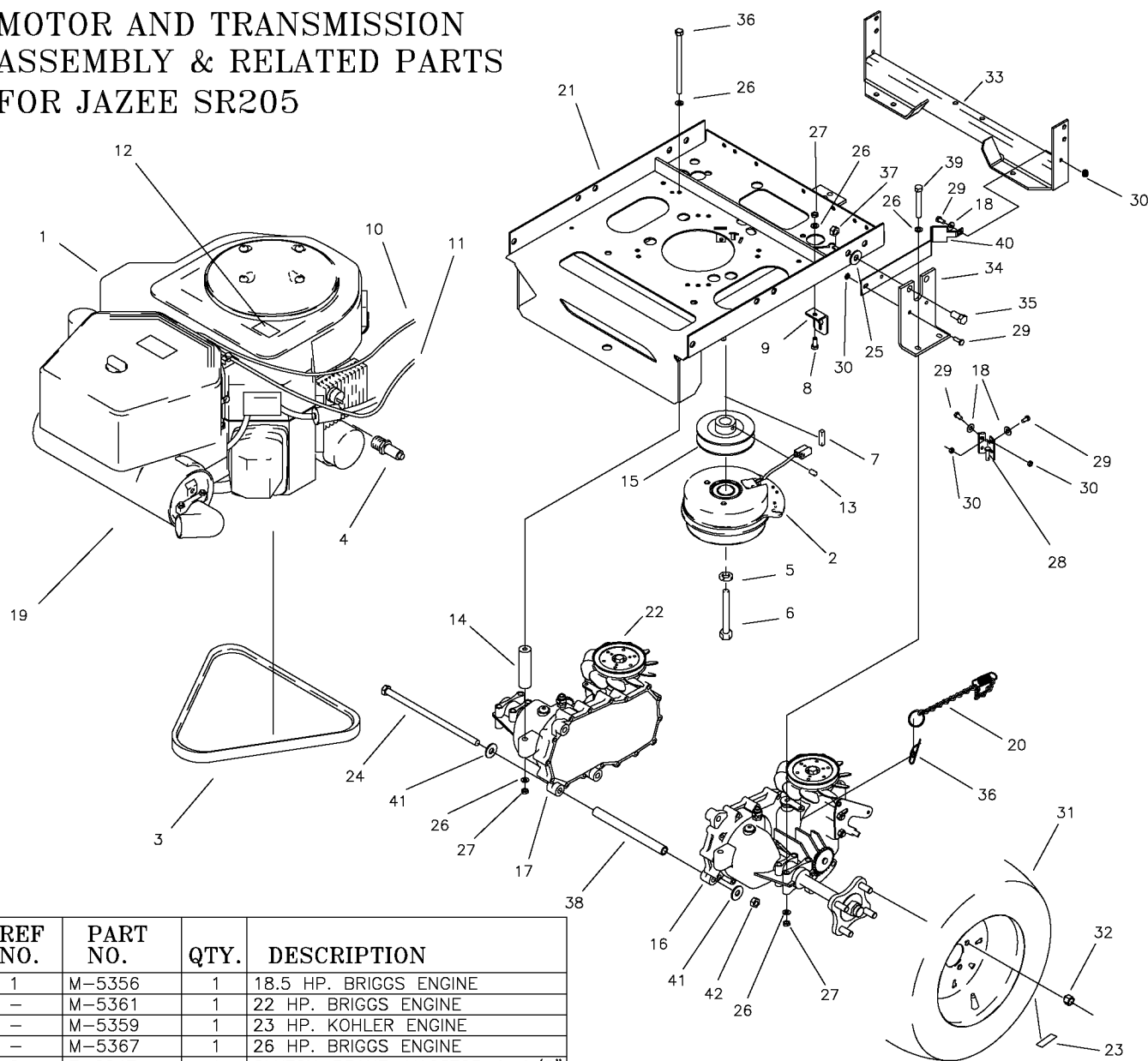

REF NO.	PART NO.	QTY.	DESCRIPTION
1	M-5356	1	18.5 HP. BRIGGS ENGINE
-	M-5361	1	22 HP. BRIGGS ENGINE
-	M-5359	1	23 HP. KOHLER ENGINE
-	M-5367	1	26 HP. BRIGGS ENGINE
2	E-6247	1	CLUTCH-BRAKE, MAGSTOP 1-1/8"
-	E-6317	1	CLUTCH-BRAKE, MAGSTOP 1"
3	D-3524	1	V-BELT-A71 KEVLAR
4	H-2497	1	OIL DRAIN VALVE
5	F-1019-04	1	7/16 LOCK WASHER
6	F-1904	1	7/16-20 X 2-1/2"
7	621-113P	1	KEY, 1/4 SQ. X 1-1/4"
8	F-1546	2	5/16-18 X 3/4" BOLT
9	659-119P	2	FREE WHEEL ANCHOR
10	H-2287	1	CHOKE CABLE, 22HP & 26HP
-	H-2403	-	CHOKE CABLE, 18.5 HP
-	H-2404	-	CHOKE CABLE, 23 HP
11	H-2236	1	THROTTLE CABLE 22, 23, & 26HP
-	H-2402	-	THROTTLE CABLE, 18.5 HP
12	P-10077	1	DECAL, "CLEAN"
13	F-1228	1	SETSCREW, 1/4" X 1/4"
14	659-121P	2	REAR HYDRO SPACER
15	D-3726	1	MOTOR PULLEY, 1" BORE
-	647-036P	1	MOTOR PULLEY, 1-1/8" BORE
16	D-3783-01	1	IZT TRANSAXLE HHDRO (RH)
17	D-3783-02	1	IZT TRANSAXLE HYDRO (LH)
18	F-1009-01	4	1/4" FLAT WASHER
19	H-2464	1	MUFFLER ASSEMBLY
20	659-066P	2	FREEWHEEL CHAIN W/SPRING
21	659-174W	1	MOTOR MOUNT
22	H-2539	2	FAN BLADE REPLACEMENT

REF NO.	PART NO.	QTY.	DESCRIPTION
23	P-11384	2	DECAL, TIRE PRESSURE, 12 PSI
24	F-2031	1	3/8-16 X 11" HEX BOLT
25	F-1009-05	4	1/2" FLAT WASHER
26	F-1009-02	14	5/16" FLAT WASHER
27	F-1125	8	5/16-18 LOCK NUT
28	659-015W	1	CLUTCH STOP WELDMENT
29	F-1015-02	8	1/4-20 X 5/8" GR. 5
30	F-1158	8	1/4-20 LOCK NUTS
31	D-3729	2	TIRE, 18 X 8.5-8
32	F-1499	8	LUG NUT, 1/2 X 20
33	659-160W	1	BRACE WELDMENT
34	659-116P	2	HYDRO MOUNT BRACE
35	F-1759	2	1/2-13 X 1" BOLT
36	F-1652	2	5/16-18 X 6" BOLT
37	F-1005-05	2	1/2" STOVER LOCK NUT
38	659-120P	1	HYDRO BRACE
39	F-1544	4	5/16-18 X 3" BOLT
40	659-125P	2	FAN SHROUD
41	F-1009-03	2	3/8" FLAT WASHER
42	F-1005-03	1	3/8-16 LOCK NUT

# MOTOR AND TRANSMISSION ASSEMBLY & RELATED PARTS FOR JAZEE PRO SR355

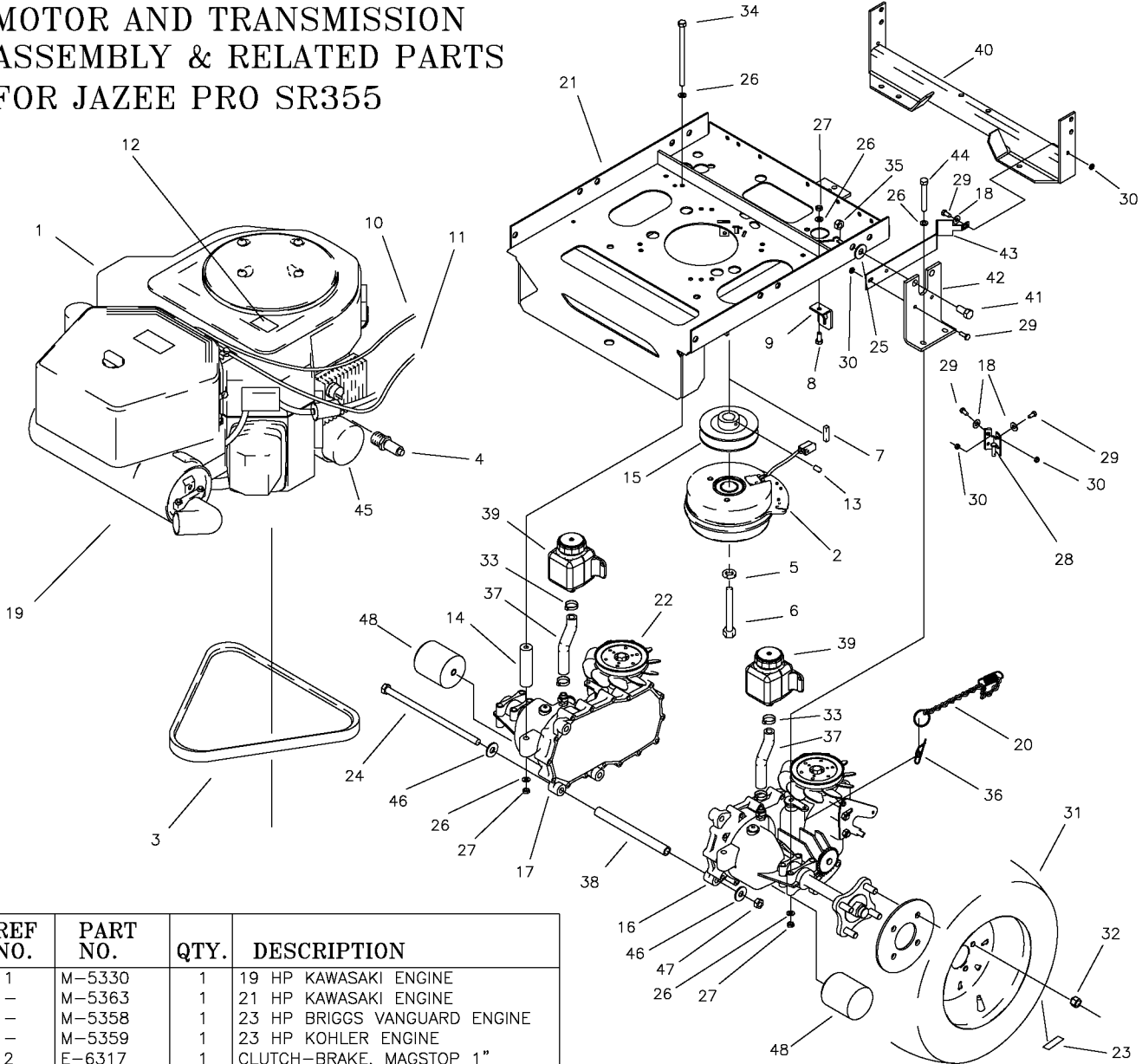

REF NO.	PART NO.	QTY.	DESCRIPTION
1	M-5330	1	19 HP KAWASAKI ENGINE
-	M-5363	1	21 HP KAWASAKI ENGINE
-	M-5358	1	23 HP BRIGGS VANGUARD ENGINE
-	M-5359	1	23 HP KOHLER ENGINE
2	E-6317	1	CLUTCH-BRAKE, MAGSTOP 1"
-	E-6247	1	CLUTCH-BRAKE, 1-1/8" BORE
3	D-3524	1	V-BELT-A71 KEVLAR
4	H-2497	1	OIL DRAIN VALVE
5	F-1019-04	1	7/16 LOCK WASHER
6	F-1904	1	7/16-20 X 2-1/2"
7	621-113P	1	KEY, 1/4 SQ. X 1-1/4"
8	F-1546	2	5/16-18 X 3/4" BOLT
9	659-119P	2	FREE WHEEL ANCHOR
10	H-2404	1	CHOKE CABLE, KAWASAKI/KOHLER
-	H-2235	-	CHOKE CABLE, 23 HP BRIGGS
11	H-2236	1	THROTTLE CABLE
12	P-10077	1	DECAL, "CLEAN"
13	F-1228	1	SETScrew, 1/4" X 1/4"
14	659-121P	2	REAR HYDRO SPACER
15	659-153P	1	MOTOR PULLEY, 1" BORE
-	659-154P	-	MOTOR PULLEY, 1-1/8" BORE
16	D-3788-01	1	TRANSAXLE ZT-2800 (RH)
17	D-3788-02	1	TRANSAXLE ZT-2800 (LH)
18	F-1009-01	4	1/4" FLAT WASHER
19	H-2284	1	MUFFLER ASSEMBLY, 23 KAWASAKI
-	H-2515	1	MUFFLER ASSEMBLY, 23 VANGUARD
20	661-066P	2	FREEWHEEL CHAIN W/SPRING
21	659-174W	1	MOTOR MOUNT
22	H-2539	2	FAN BLADE REPLACEMENT
23	P-11384	2	DECAL, TIRE PRESSURE, 12 PSI
24	F-2007	1	3/8-16 X 12-1/2" BOLT
25	F-1009-05	4	1/2" FLAT WASHER

REF NO.	PART NO.	QTY.	DESCRIPTION
26	F-1009-02	14	5/16" FLAT WASHER
27	F-1125	8	5/16-18 LOCK NUT
28	659-015W	1	CLUTCH STOP WELDMENT
29	F-1015-02	8	1/4-20 X 5/8" GR. 5
30	F-1158	8	1/4-20 LOCK NUTS
31	D-3787	2	TIRE, 20"-12 X 10 (WITH 52" & 60" DECK)
-	D-3353	2	TIRE, 20"-10 X 10 (WITH 48" DECK)
32	F-1499	8	LUG NUT, 1/2 X 20
33	H-2535	4	HOSE CLAMP
34	F-1652	2	5/16-18 X 6" BOLT
35	F-1005-05	2	1/2" STOVER LOCK NUT
36	F-1492	2	RUE RING, 5/16-3/8 PIN
37	H-2549	2	HOSE, 5" LONG
38	659-173P	1	HYDRO BRACE
39	D-3791	2	SMALL HYDRO TANK
40	659-160W	1	BRACE WELDMENT
41	F-1759	2	1/2-13 X 1" BOLT
42	659-116P	2	HYDRO MOUNT BRACE
43	659-156P	2	FAN SHROUD
44	F-1544	4	5/16-18 X 3" BOLT
45	H-2567	1	OIL FILTER, JAZEE PRO
46	F-1009-03	2	3/8" FLAT WASHER
47	F-1005-03	1	3/8-16 LOCK NUT
48	H-2567	2	TRANSAXLE OIL FILTER

# E-6405 WIRE HARNESS & RELATED PARTS FOR 18.5 HP, 22 HP & 26 HP BRIGGS

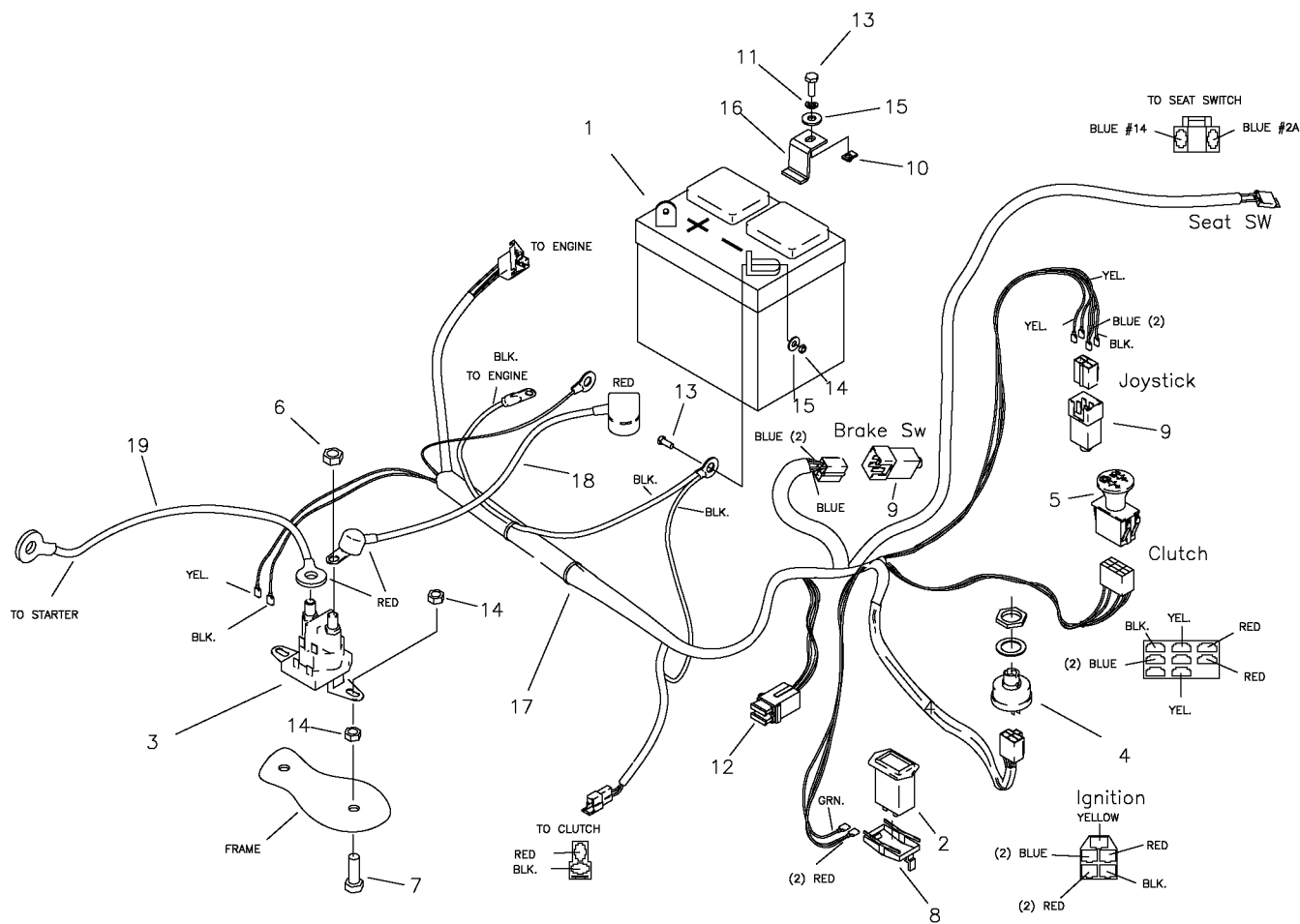

REF NO.	PART NO.	QTY.	DESCRIPTION
1	E-5812	1	BATTERY
2	E-5878	1	HOUR METER
3	E-6054	1	SOLENOID
4	E-5873	1	START SWITCH
5	E-6403	1	CLUTCH SWITCH
6	F-1011-01	2	1/4-20 NUT
7	F-1015-05	2	1/4-20 X 1" GR. 5
8	E-6369	1	RETAINER CLIP
9	E-6297	2	BRAKE SWITCH
10	F-1858	1	1/4-20 U-NUT
11	F-1019-01	1	1/4" LOCK WASHER
12	E-6207	2	FUSE, #ATC-30
13	F-1538	3	1/4-20 X 3/4" GR. 5
14	F-1158	6	1/4-20 LOCK NUT
15	F-1009-01	5	1/4" FLAT WASHER
16	659-137P	1	BATTERY HOLD DOWN
17	E-6405	1	WIRE HARNESS
18	E-6418	1	CABLE, BATTERY TO SOLENOID
19	E-6419	1	CABLE, SOLENOID TO ENGINE
-NOT SHOWN-			
	E-6374	1	SEAT SWITCH (SCREW MOUNT)
	E-6443	1	SEAT SWITCH (TWIST LOCK MOUNT)
	E-6281	1	COVER (KEY SWITCH)



# E-6415 WIRE HARNESS & RELATED PARTS FOR 19 HP & 21 HP KAWASAKI & 23 HP BRIGGS & KOHLER (JOYSTICK)

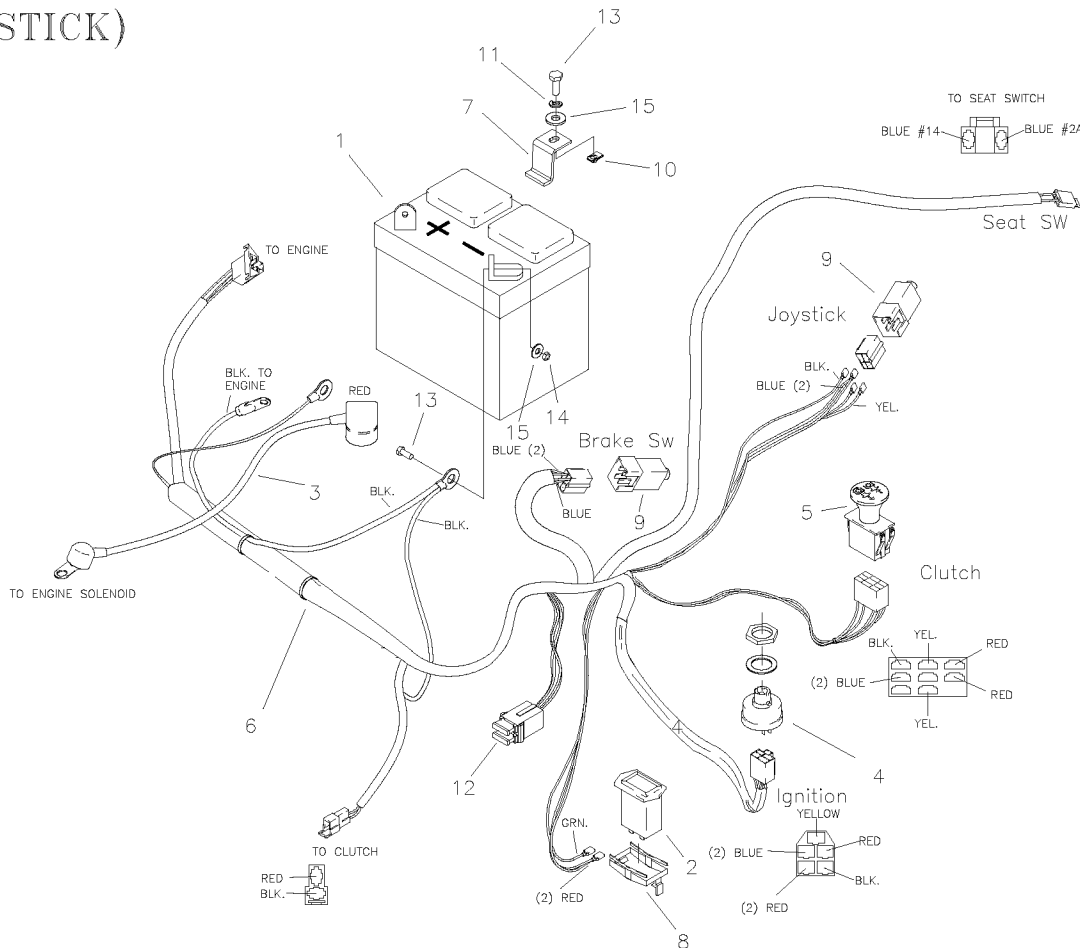

REF NO.	PART NO.	QTY.	DESCRIPTION
1	E-5812	1	BATTERY
2	E-5878	1	HOUR METER
3	E-6418	1	CABLE, BATTERY TO SOLENOID
4	E-5873	1	START SWITCH
5	E-6403	1	CLUTCH SWITCH
6	E-6405	1	WIRE HARNESS
7	659-137P	1	BATTERY HOLD DOWN
8	E-6369	1	RETAINER CLIP
9	E-6297	2	BRAKE SWITCH
10	F-1858	1	1/4-20 U-NUT
11	F-1019-01	1	1/4" LOCK WASHER
12	E-6207	2	FUSE, #ATC-30
13	F-1538	3	1/4-20 X 3/4" GR. 5
14	F-1158	2	1/4-20 LOCK NUT
15	F-1009-01	5	1/4" FLAT WASHER
-NOT SHOWN-			
	E-6374	1	SEAT SWITCH (SCREW MOUNT)
	E-6443	1	SEAT SWITCH (TWIST LOCK MOUNT)
	E-6281	1	COVER (KEY SWITCH)

# E-6416 WIRE HARNESS & RELATED PARTS FOR 19HP & 21HP KAWASAKI & 23HP BRIGGS & KOHLER (TWINSTICK)

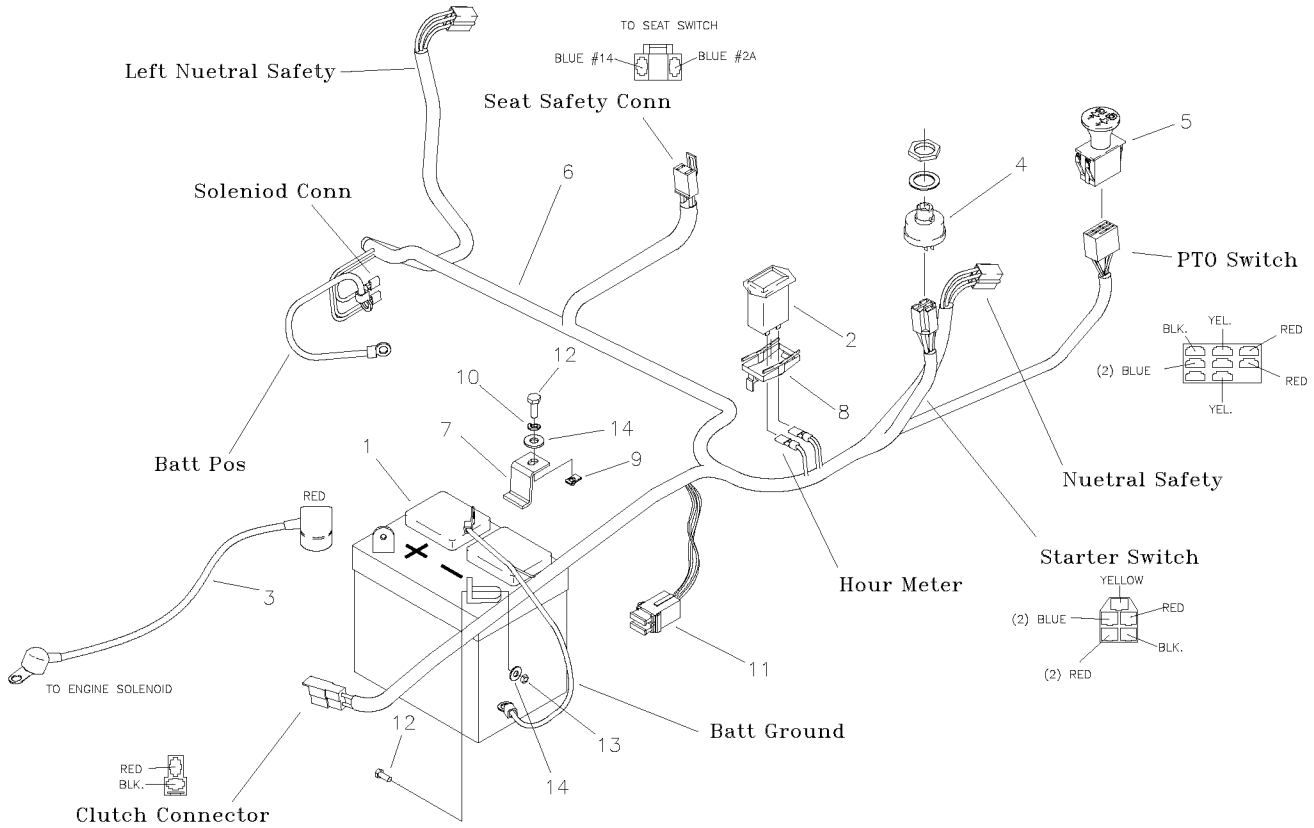

REF NO.	PART NO.	QTY.	DESCRIPTION
1	E-5812	1	BATTERY
2	E-5878	1	HOUR METER
3	E-6418	1	CABLE, BATTERY TO SOLENOID
4	E-5873	1	START SWITCH
5	E-6403	1	CLUTCH SWITCH
6	E-6416	1	WIRE HARNESS
7	659-137P	1	BATTERY HOLD DOWN
8	E-6369	1	RETAINER CLIP
9	F-1858	1	1/4-20 U-NUT
10	F-1019-01	1	1/4" LOCK WASHER
11	E-6207	2	FUSE, #ATC-30
12	F-1538	3	1/4-20 X 3/4" GR. 5
13	F-1158	2	1/4-20 LOCK NUT
14	F-1009-01	5	1/4" FLAT WASHER
-NOT SHOWN-			
	E-6374	1	SEAT SWITCH (SCREW MOUNT)
	E-6443	1	SEAT SWITCH (TWIST LOCK MOUNT)
	E-6281	1	COVER (KEY SWITCH)

# E-6417 KAWASAKI ADAPTER HARNESS & RELATED PARTS

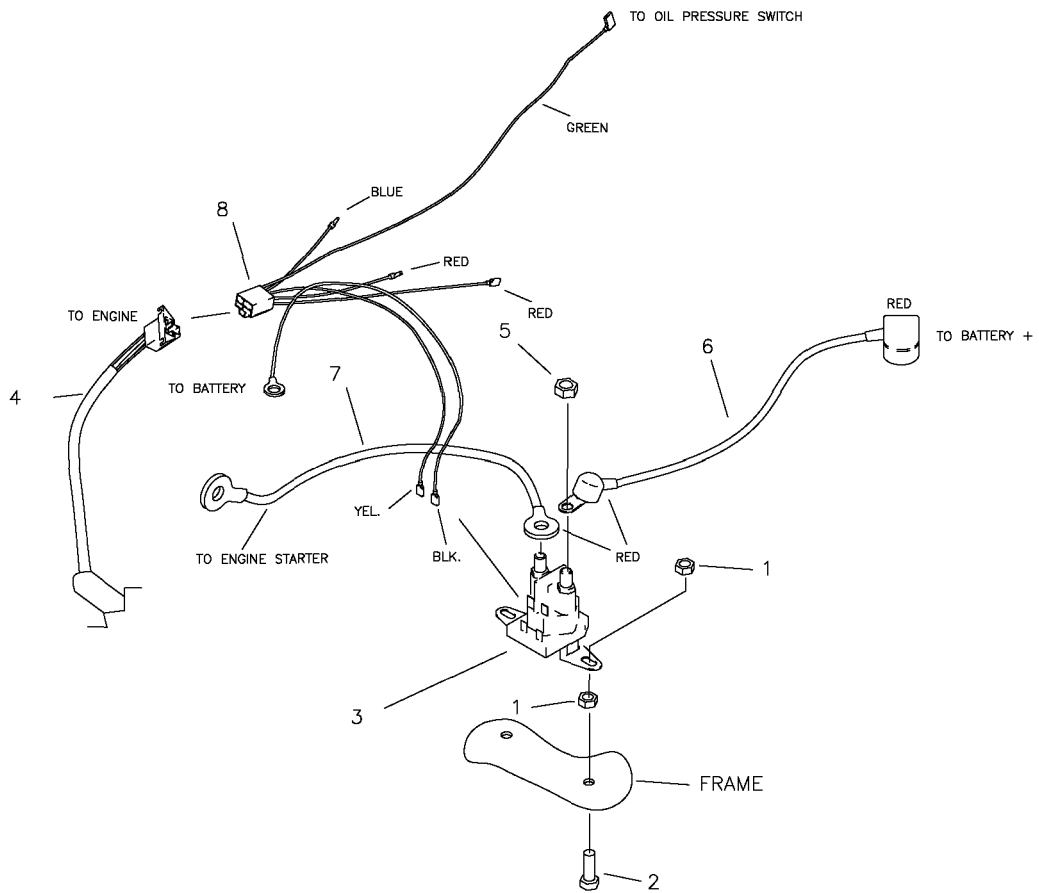

REF NO.	PART NO.	QTY.	DESCRIPTION
1	F-1158	4	1/4-20 LOCK NUT
2	F-1015-05	2	1/4-20 X 1" GR. 5
3	E-6054	1	SOLENOID
4	E-6415	1	KOHLER WIRE HARNESS (JOYSTICK)
-	E-6416	1	KOHLER WIRE HARNESS (TWINSTICK)
5	F-1011-01	2	1/4-20 NUT
6	E-6418	1	CABLE, BATTERY TO SOLENOID
7	E-6419	1	CABLE, SOLENOID TO ENGINE
8	E-6417	1	KAWASAKI HARNESS ADAPTER

# E-6436 BRIGGS ADAPTER HARNESS & RELATED PARTS

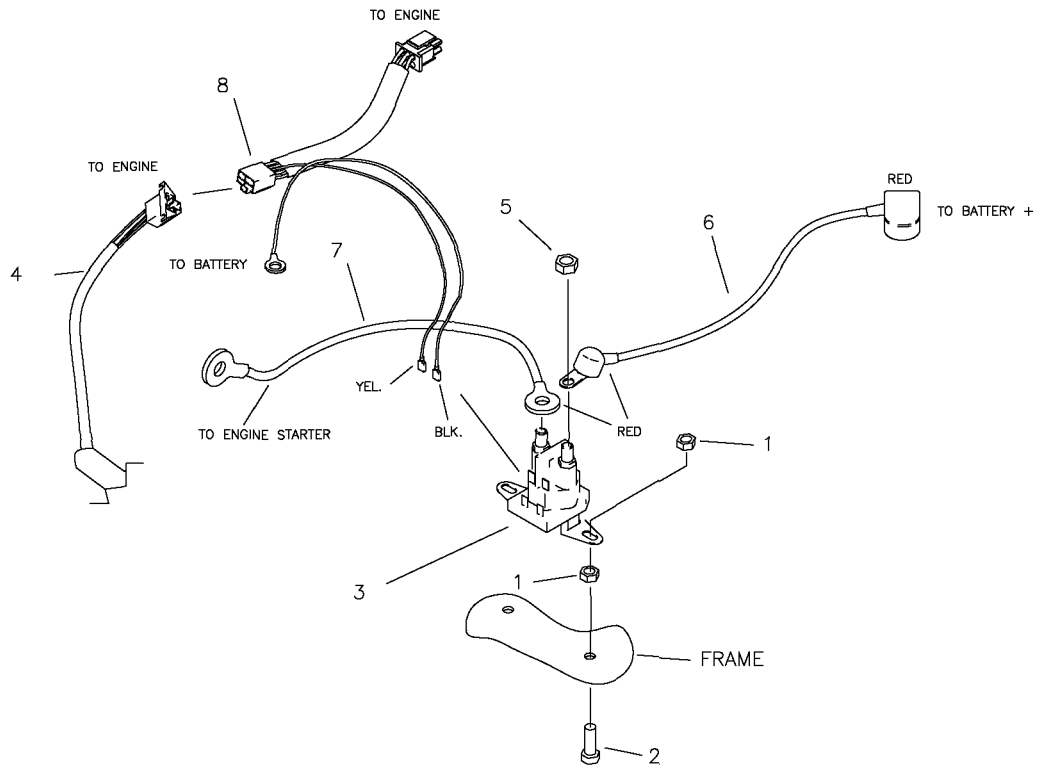

REF NO.	PART NO.	QTY.	DESCRIPTION
1	F-1158	4	1/4-20 LOCK NUT
2	F-1015-05	2	1/4-20 X 1" GR. 5
3	E-6054	1	SOLENOID
4	E-6415	1	KOHLER WIRE HARNESS (JOYSTICK)
-	E-6416		KOHLER WIRE HARNESS (TWINSTICK)
5	F-1011-01	2	1/4-20 NUT
6	E-6418	1	CABLE, BATTERY TO SOLENOID
7	E-6419	1	CABLE, SOLENOID TO ENGINE
8	E-6436	1	BRIGGS ENGINE ADAPTER