

Repair Parts Manual

C O U N T R Y
CLIPPER®
Z E R O T U R N M O W E R

C H A R G E R™

1050/1055

COUNTRY CLIPPER CHARGER

1050/1055 ZERO TURN RADIUS MOWER

TABLE OF CONTENTS

SECTION 1 – MOWER DECKS AND RELATED PARTS

1. 52" DECK ASSEMBLY
2. 60" DECK ASSEMBLY
3. DECK SPINDLE ASSEMBLY
4. DOUBLE IDLER & RELATED PARTS - 52" DECK
5. DOUBLE IDLER & RELATED PARTS - 60" DECK
6. MOLDED CHUTE ASSEMBLY
7. LIFT HANDLE ASSEMBLY & RELATED PARTS
8. LIFT ASSEMBLY & RELATED PARTS
9. TRANSMISSION IDLERS & RELATED PARTS

SECTION 2 – TRACTOR FRAME AND RELATED PARTS

10. CASTER WHEEL ASSEMBLY
11. FRAME SIDES & RELATED PARTS
12. FENDER ASSEMBLY
13. SEAT, FOOT DECK ASSEMBLY & RELATED PARTS
14. FRONT STEP ASSEMBLY
15. R.O.P.S. ASSEMBLY (ROLL OVER PROTECTION SYSTEM) & RELATED PARTS

SECTION 3 – TRACTOR DRIVE AND RELATED PARTS

16. FUEL TANK ASSEMBLY
17. JOYSTICK STEERING CONTROL & RELATED PARTS
18. JOYSTICK STEERING CONTROL & RELATED PARTS (CONT)
19. JOYSTICK STEERING CONTROL & RELATED PARTS (CONT)
20. TWIN STICK STEERING CONTROL & RELATED PART
21. PARKING BRAKE ASSEMBLY & RELATED PARTS
22. GEAR MOTOR WHEEL ASSEMBLY
23. MOTOR ASSEMBLY & RELATED PARTS FOR 25.5HP KAWASAKI
24. MOTOR ASSEMBLY & RELATED PARTS FOR 26HP EFI KOHLER
25. HIGH PRESSURE LINES & FITTINGS
26. OIL RETURN LINES & COOLER ASSEMBLY
27. E-6415 WIRE HARNESS ASSEMBLY & RELATED PARTS
28. E-6416 WIRE HARNESS ASSEMBLY & RELATED PARTS
29. E-6417 WIRE HARNESS ADAPTER & RELATED PARTS
30. E-6547 WIRE HARNESS ADAPTER & RELATED PARTS

52" HEAVY
DECK ASSEMBLY
{668V-002A}

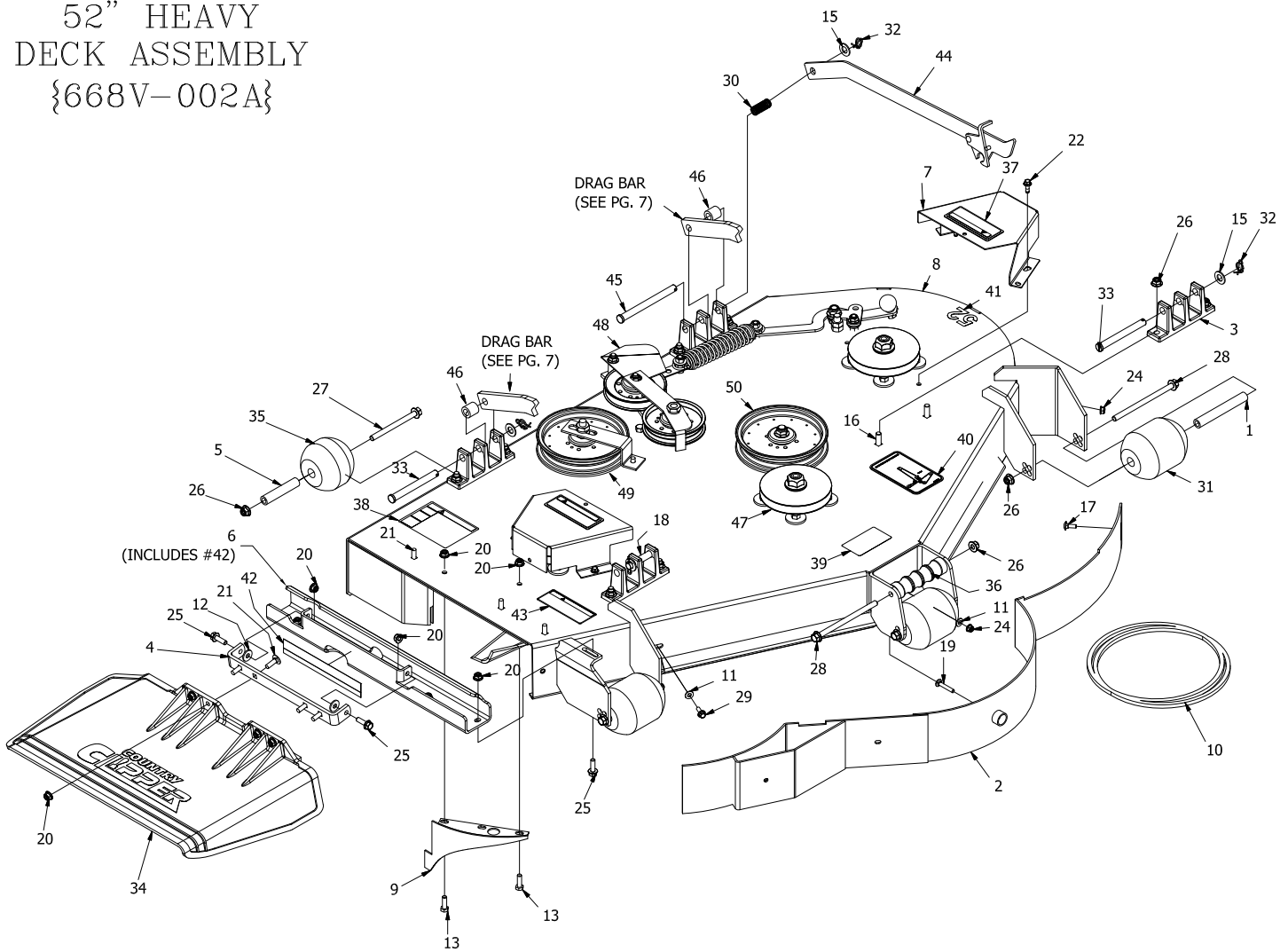

REF NO.	PART NO.	QTY.	DESCRIPTION	REF NO.	PART NO.	QTY.	DESCRIPTION
1	609-183P	3	BUSHING	27	F-2160	2	FHCS, 3/8-16 x 4 1/2", YZ, GR5
2	629-229W	1	DUST BAFFLE, 52"	28	F-2161	4	FHCS, 3/8-16 x 6", YZ, GR5
3	643-016W	4	Hanger Weldment	29	F-2162	1	FHCS, 1/4-20 x 3/4", GR5, YZ
4	643-110P	1	CHUTE HINGE	30	F-2575	1	SPRING, COMP .656 X .052 X 1.97
5	643-126P	2	BUSHING	31	H-1948	3	Roller, 3-3/4 DIA. x 4-13/16L
6	643-135A	1	OUTLET STIFFENER w/DECAL	32	H-2239	4	1/2" Rue Ring
7	660-146A	2	PULLEY COVER w/DECALS	33	H-2240	2	1/2" x 4-1/2" Clevis Pin
8	668-075A	1	52" HEAVY DECK w/DECALS	34	H-2723	1	Chute, Discharge, Small
9	686-006W	1	SPLITTER BAFFLE	--	643-111A	1	CHUTE ASSEMBLY
10	D-3872	1	BELT, B-184	35	H-2772	2	Roller, 3-3/4 DIA. x 3 1/4"L
11	F-1009-01	2	1/4" Flat Washer	36	H-2787	1	GRIP, DECK HANDLE
12	F-1009-02	2	5/16" Flat Washer	37	P-10935	2	Decal, WARNING
13	F-1015-15	2	5/16-18 x 1" Capscrew	38	P-10941	1	DECAL "DANGER ROTATING BLADES"
14	F-1394	3	3/8-16 x 1" Capscrew	39	P-11413	1	DECAL, HOIST POINT
15	F-1521	8	1/2" WASHER, CUSTOM	40	P-11932	1	DECAL, JAZEE DECK BELT ROUTING
16	F-1672	8	3/8-16 x 1-1/4" Carriage Bolt	41	P-11951	1	DECAL, DECK SIZE, 52
17	F-1823	1	Carriage Bolt, 1/4 X 3/4"	42	P-12496	1	DECAL, MISSING CHUTE
18	F-1889	1	1/2 x 2-5/8" Clevis Pin	43	P-12706	1	WARNING DECAL, DISCHARGE CHUTE
19	F-1935	1	CARRIAGE BOLT, 1/4 X 1-1/2"	44	625-114A	1	DECK PROP ASS'Y, EDGE XLT
20	F-2063	13	Nut, 5/16-18 Nyloc, Flanged	45	H-2718	1	1/2" x 5-1/2" Clevis Pin
21	F-2066	8	5/16-18 x 1" CARRIAGE BOLT,	46	707-046P	2	SPACER
22	F-2119	4	FHCS, 1/4-20 x 0.75, YZ, LOCK PATCH, GR5	47	-----	3	SPINDLE ASS'Y (SEE pg.4)
23	F-2124	1	FHCS, 3/8-16 x 0.75, YZ, GR5	48	-----	1	DOUBLE IDLER ASS'Y (SEE pg.5)
24	F-2132	2	NUT, 1/4-20 NYLOC, FLANGED	49	-----	1	REAR IDLER ASS'Y (SEE pg.5)
25	F-2148	3	FHCS, 5/16-18 x 1.00, YZ, GR5	50	-----	1	FRONT IDLER ASS'Y (SEE pg.5)
26	F-2151	18	Nut, 3/8-16 Nyloc, Flanged				

60" HEAVY DECK ASSEMBLY {668U-002A}

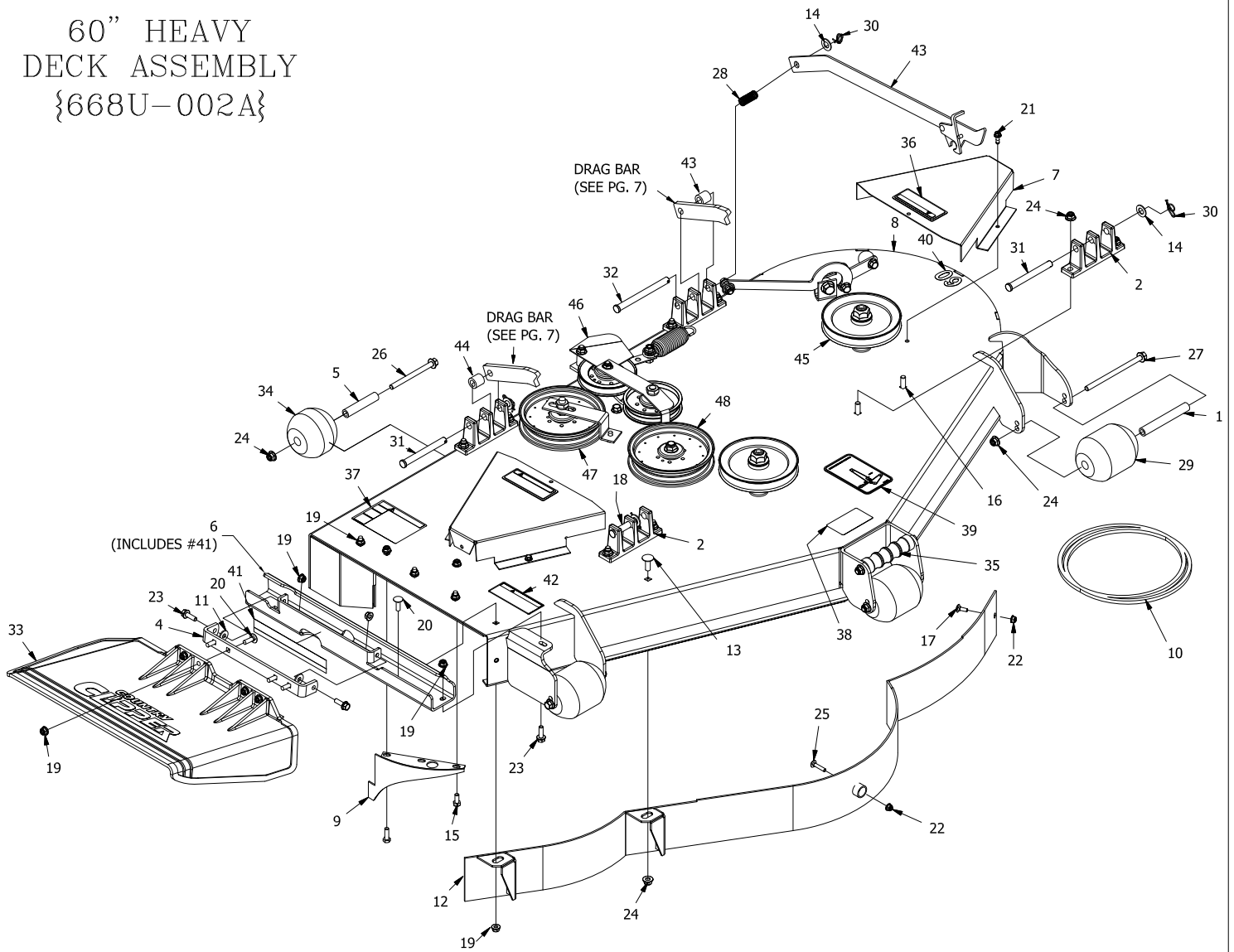

REF NO.	PART NO.	QTY.	DESCRIPTION	REF NO.	PART NO.	QTY.	DESCRIPTION
1	609-183P	3	BUSHING	26	F-2160	2	FHCS, 3/8-16 x 4 1/2", YZ, GR5
2	643-016W	4	Hanger Weldment	27	F-2161	4	FHCS, 3/8-16 x 6", YZ, GR5
3	643-104W	1	60" DUST BAFFLE WELDMENT	28	F-2575	1	SPRING, COMP .656 X .052 X 1.97
4	643-110P	1	CHUTE HINGE	29	H-1948	3	Roller, 3-3/4 DIA. x 4-13/16L
5	643-126P	2	BUSHING	30	H-2239	4	1/2" Rue Ring
6	643-135A	1	OUTLET STIFFENER w/DECAL	31	H-2240	2	1/2" x 4-1/2" Clevis Pin
7	668-061A	2	PULLEY COVER w/DECALS	32	H-2718	1	1/2" x 5-1/2" Clevis Pin
8	668-076A	1	60" DECK WLD w/DECALS	33	H-2723	1	Chute, Discharge, Small
9	686-006W	1	SPLITTER BAFFLE	--	643-111A	1	CHUTE ASSEMBLY
10	D-3872	1	BELT, B-184	34	H-2772	2	Roller, 3-3/4 DIA. x 3 1/4"L
11	F-1009-02	2	5/16" Flat Washer	35	H-2787	1	GRIP, DECK HANDLE
12	F-1015-15	1	5/16-18 x 1" Capscrew	36	P-10935	2	Decal, WARNING
13	F-1274	1	3/8-16 X 1" CARRIAGE BOLT	37	P-10941	1	DECAL "DANGER ROTATING BLADES"
14	F-1521	6	1/2" WASHER, CUSTOM	38	P-11413	1	DECAL, HOIST POINT
15	F-1546	1	5/16-18 x 3/4" Capscrew	39	P-11932	1	DECAL, JAZEE DECK BELT ROUTING
16	F-1672	8	3/8-16 x 1-1/4" Carraige Bolt	40	P-11952	1	DECAL, DECK SIZE, 60
17	F-1823	1	Carriage Bolt, 1/4 X 3/4"	41	P-12496	1	DECAL, MISSING CHUTE
18	F-1889	1	1/2 x 2-5/8" Clevis Pin	42	P-12706	1	WARNING DECAL, DISCHARGE CHUTE
19	F-2063	14	Nut, 5/16-18 Nyloc, Flanged	43	625-114A	1	DECK PROP ASS'Y, EDGE XLT
20	F-2066	9	5/16-18 x 1" CARRIAGE BOLT,	44	707-046P	2	SPACER
21	F-2119	4	FHCS, 1/4-20 x 0.75, YZ, LOCK PATCH, GR5	45	-----	3	SPINDLE ASS'Y (SEE pg.4)
22	F-2132	2	NUT, 1/4-20 NYLOC, FLANGED	46	-----	1	DOUBLE IDLER ASS'Y (SEE pg.7)
23	F-2148	3	FHCS, 5/16-18 x 1.00, YZ, GR5	47	-----	1	REAR IDLER ASS'Y (SEE pg.7)
24	F-2151	24	Nut, 3/8-16 Nyloc, Flanged	48	-----	1	FRONT IDLER ASS'Y (SEE pg.7)
25	F-2157	1	CARRIAGE BOLT, 1/4 X 1-1/4"				

DECK SPINDLE ASSEMBLY

629FN-001A

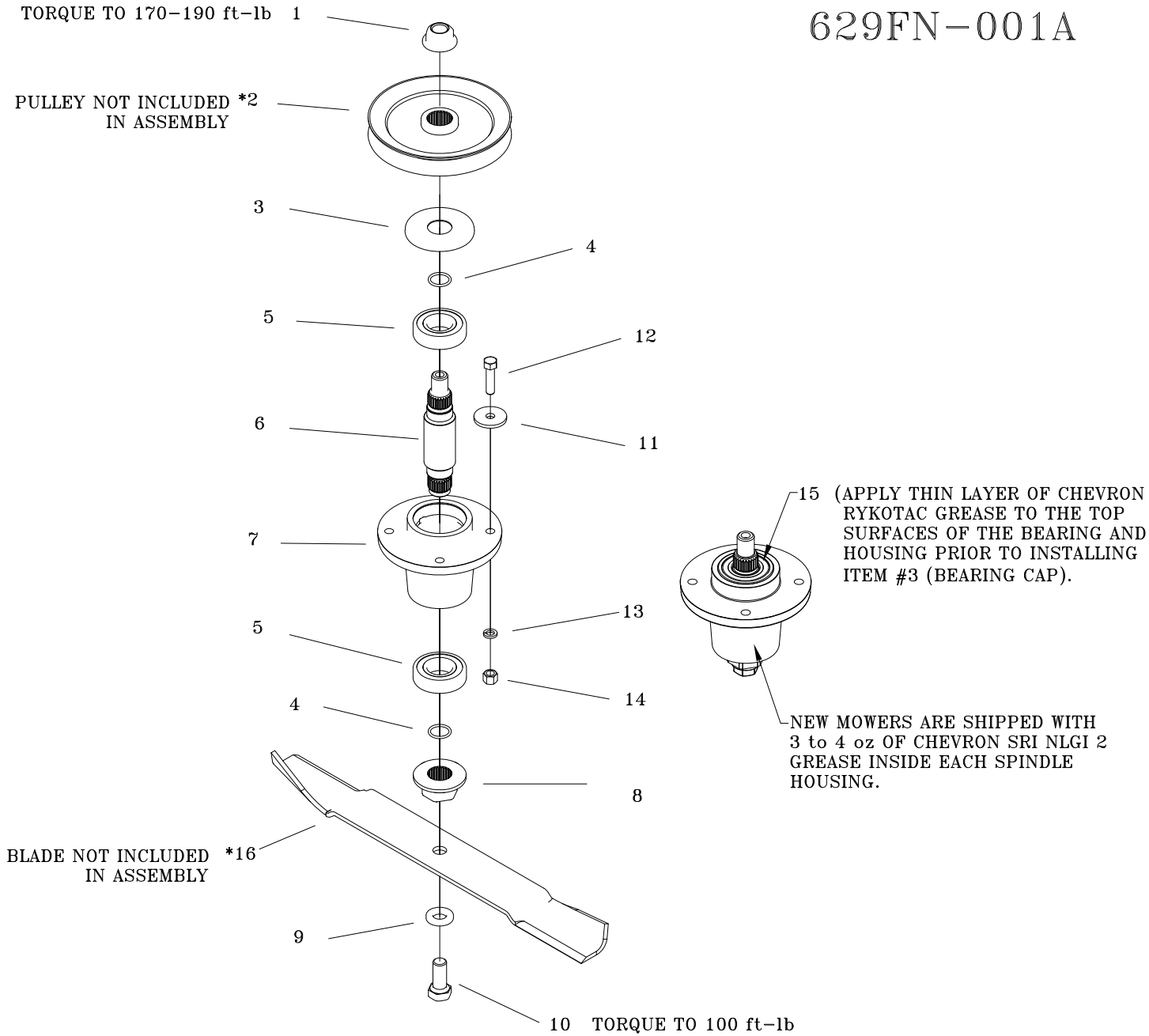

REF NO.	PART NO.	QTY.	DESCRIPTION	REF NO.	PART NO.	QTY.	DESCRIPTION
1	F-2078	1	3/4-6 TOP LOCK NUT	12	F-1572	4	3/8-24 X 1.5 CAP SCREW
2	668-050P	*	52" DECK CENTER PULLEY	13	F-1019-03	4	3/8 LOCK WASHER
*	668-042P	*	60" DECK CENTER PULLEY	14	F-1573	4	3/8-24 LOCK NUT
3	609-292P	1	CAP, BEARING	15	H-2707	1	GREASE PACKET
4	H-2639	2	O'RING, RUBBER	16	H-2884	-	FUSION, HIGH LIFT 18 3/8" CUT 52"
5	D-3867	2	BEARING, #6206	-	H-2886	-	FUSION, HIGH LIFT, 21" CUT 60"
6	609-289P	1	SHAFT, SPINDLE	OPTIONAL BLADES			
7	609-285P	1	HOUSING, SPINDLE				
8	609-288P	1	BLADE DRIVER	-	H-2660	-	BLADE, LOW LIFT, 18 3/8" CUT, 52"
9	660-099P	1	BLADE WASHER	-	H-2661	-	BLADE, LOW LIFT, 21" CUT, 60"
10	F-2073	1	5/8-11 X 1.5 HHCS GR. 8	-	H-2666	-	BLADE, GATOR, 18 3/8" CUT 52"
11	609-034P	4	SPINDLE SPACER, WASHER	-	H-2667	-	BLADE, GATOR, 21" CUT 60"

DOUBLE IDLER DRIVE BELT IDLER & RELATED PARTS 52" DECK

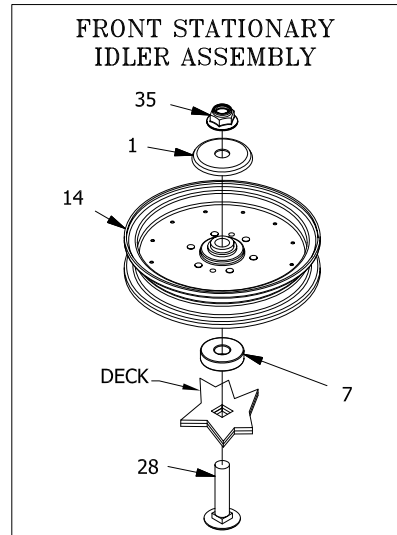
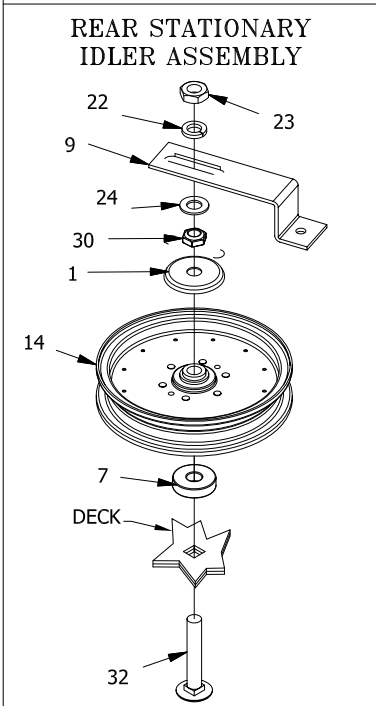
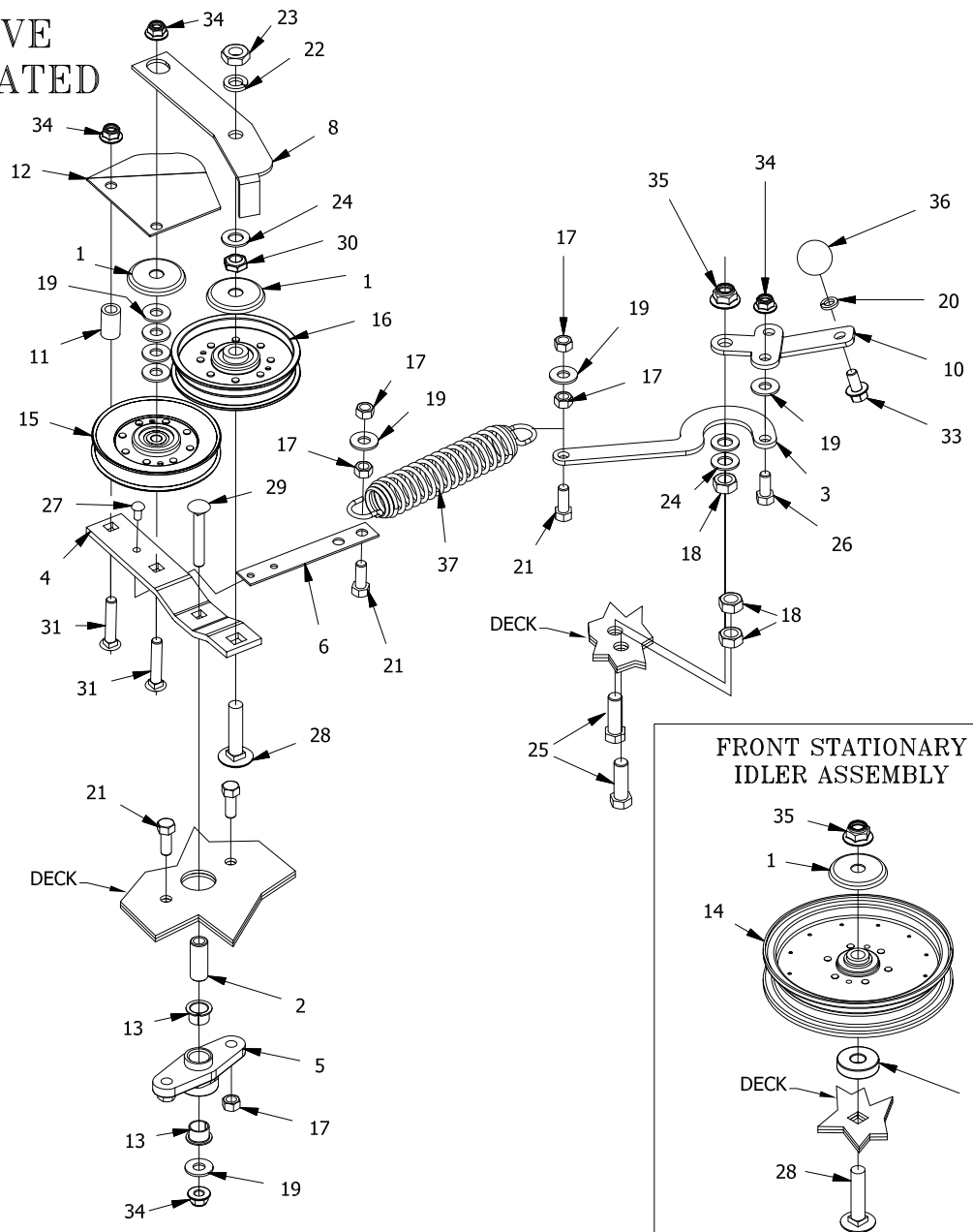

REF NO.	PART NO.	QTY.	DESCRIPTION	REF NO.	PART NO.	QTY.	DESCRIPTION
1	620-201P	4	WASHER, BEARING CAP	20	F-1019-03	13	3/8" LOCKWASHER
2	659-085P	1	Mounting Pin	21	F-1394	4	3/8-16 x 1" Capscrew
3	660-031P	1	Belt Tightner Arm	22	F-1464	2	1/2" LOCKWASHER
4	660-036P	1	Idler Arm	23	F-1489	2	1/2-13 Hex Jam Nut
5	660-039P	1	Double Idler Mount	24	F-1521	8	1/2" WASHER, CUSTOM
6	660-081P	1	EXTENSION FOR SPRING	25	F-1526	2	1/2-13 x1-1/2" Capscrew
7	660-082P	2	SPACER	26	F-1558	1	3/8-16 x 7/8" Capscrew
8	660-107P	1	BELT KEEPER	27	F-1733	1	1/4" x 1/2" DRIVE SCREW
9	660-114P	1	BELT KEEPER, SINGLE END	28	F-1822	2	1/2-13 X 2-1/4" CARRIAGE BOLT
10	660-184P	1	HANDLE, BELT TENSIONER	29	F-1865	1	3/8-16 x 2-1/2" Carraige Bolt
11	668-021P	1	SPACER, BELT GUARD	30	F-1966	2	1/2-13 THIN NYLOC NUT
12	668-029P	1	BELT GUARD	31	F-1976	2	3/8-16 x 2" Carraige Bolt
13	D-3730	2	Flanged Bushing 5/8" Bore	32	F-2047	1	1/2-13 X 3" CARRIAGE BOLT
14	D-3903	2	PULLEY, FLAT IDLER, 6" (NTN)	33	F-2124	1	FHCS, 3/8-16 x 0.75, YZ, GR5
15	D-3923	1	PULLEY, V-IDLER, 4.59 OD, AB, NTN	34	F-2151	18	Nut, 3/8-16 Nyloc, Flanged
16	D-3924	1	PULLEY, FLAT IDLER, NTN, DBL INSERT	35	F-2152	2	Nut, 1/2-13 Nyloc, Flanged
17	F-1005-03	6	3/8-16 Stover Nut	36	H-2405	1	BALL, 1-1/4"
18	F-1005-05	3	1/2-13 Stover Nut	37	H-2619	1	SPRING, 5 X 1-1/2, TAPERED ENDS
19	F-1009-03	8	3/8" Flat Washer				

DOUBLE IDLER DRIVE BELT IDLER & RELATED PARTS 60" DECK

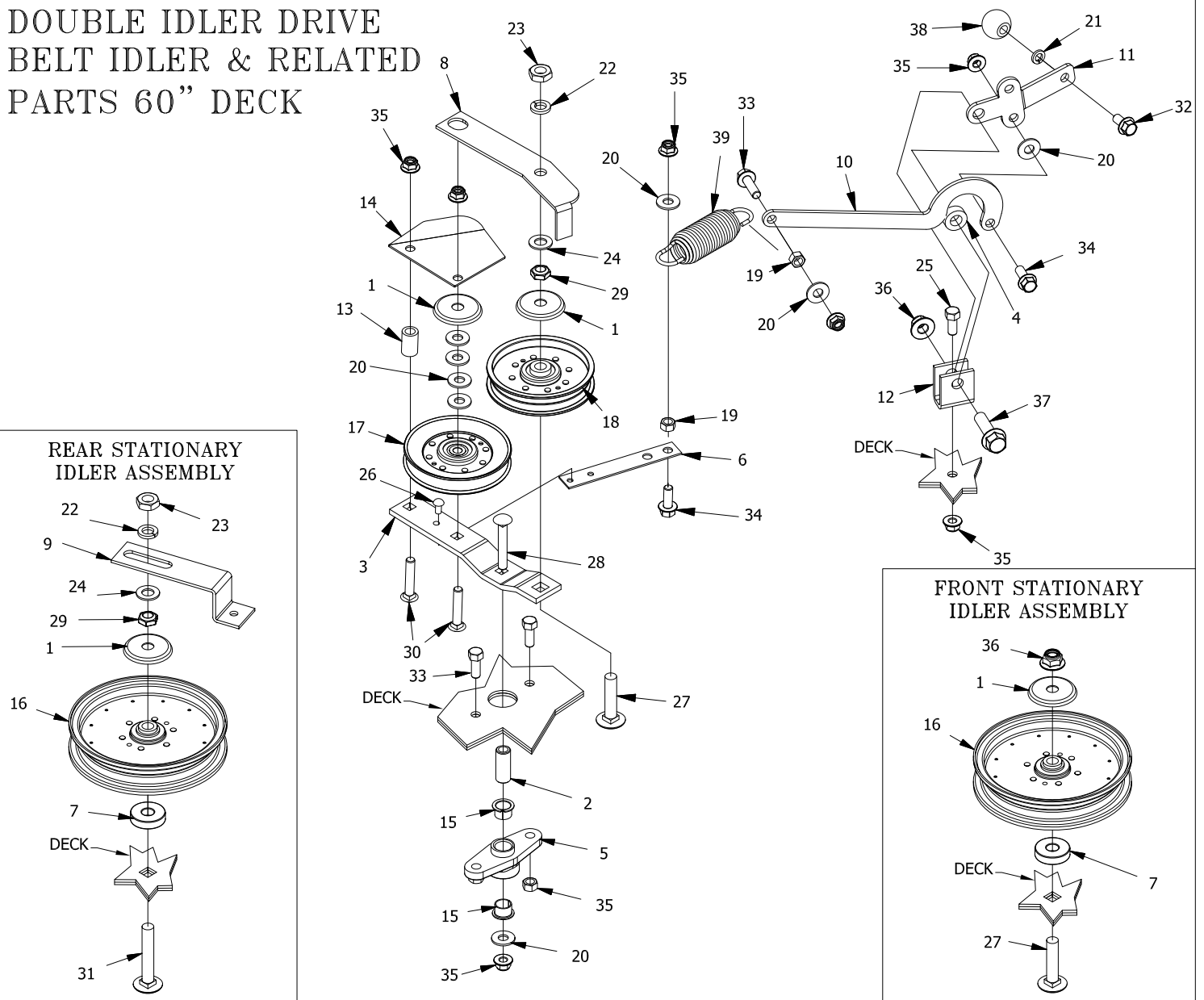

REF NO.	PART NO.	QTY.	DESCRIPTION	REF NO.	PART NO.	QTY.	DESCRIPTION
1	620-201P	4	WASHER, BEARING CAP	21	F-1019-03	13	3/8" LOCKWASHER
2	659-085P	1	Mounting Pin	22	F-1464	2	1/2" LOCKWASHER
3	660-036P	1	Idler Arm	23	F-1489	2	1/2-13 Hex Jam Nut
4	660-038P	1	3/8" Spacer	24	F-1521	6	1/2" WASHER, CUSTOM
5	660-039P	1	Double Idler Mount	25	F-1558	1	3/8-16 x 7/8" Capscrew
6	660-081P	1	EXTENSION FOR SPRING	26	F-1733	1	1/4" x 1/2" DRIVE SCREW
7	660-082P	2	SPACER	27	F-1822	2	1/2-13 X 2-1/4" CARRIAGE BOLT
8	660-107P	1	BELT KEEPER	28	F-1865	1	3/8-16 x 2-1/2" Carraige Bolt
9	660-114P	1	BELT KEEPER, SINGLE END	29	F-1966	2	1/2-13 THIN NYLOC NUT
10	660-182P	1	BELT TIGHTENER ARM	30	F-1976	2	3/8-16 x 2" Carraige Bolt
11	660-184P	1	HANDLE, BELT TENSIONER	31	F-2047	1	1/2-13 X 3" CARRIAGE BOLT
12	661-015P	1	SHACKLE	32	F-2124	1	FHCS, 3/8-16 x 0.75, YZ, GR5
13	668-021P	1	SPACER, BELT GUARD	33	F-2125	3	FHCS, 3/8-16 x 1.25, YZ, GR5
14	668-029P	1	BELT GUARD	34	F-2141	2	FHCS, 3/8-16 x 1", YZ, GR5
15	D-3730	2	Flanged Bushing 5/8" Bore	35	F-2151	24	Nut, 3/8-16 Nyloc, Flanged
16	D-3903	2	PULLEY, FLAT IDLER, 6" (NTN)	36	F-2152	2	Nut, 1/2-13 Nyloc, Flanged
17	D-3923	1	PULLEY, V-IDLER, 4.59 OD, AB, NTN	37	F-2154	1	FHCS, 1/2-13 x 1-3/4", YZ, GR5
18	D-3924	1	PULLEY, FLAT IDLER, NTN, DBL INSERT	38	H-2405	1	BALL, 1-1/4"
19	F-1005-03	2	3/8-16 Stover Nut	39	H-2619	1	SPRING, 5 X 1-1/2, TAPERED ENDS
20	F-1009-03	8	3/8" Flat Washer				

MOLDED CHUTE ASSEMBLY
 {643-111A}

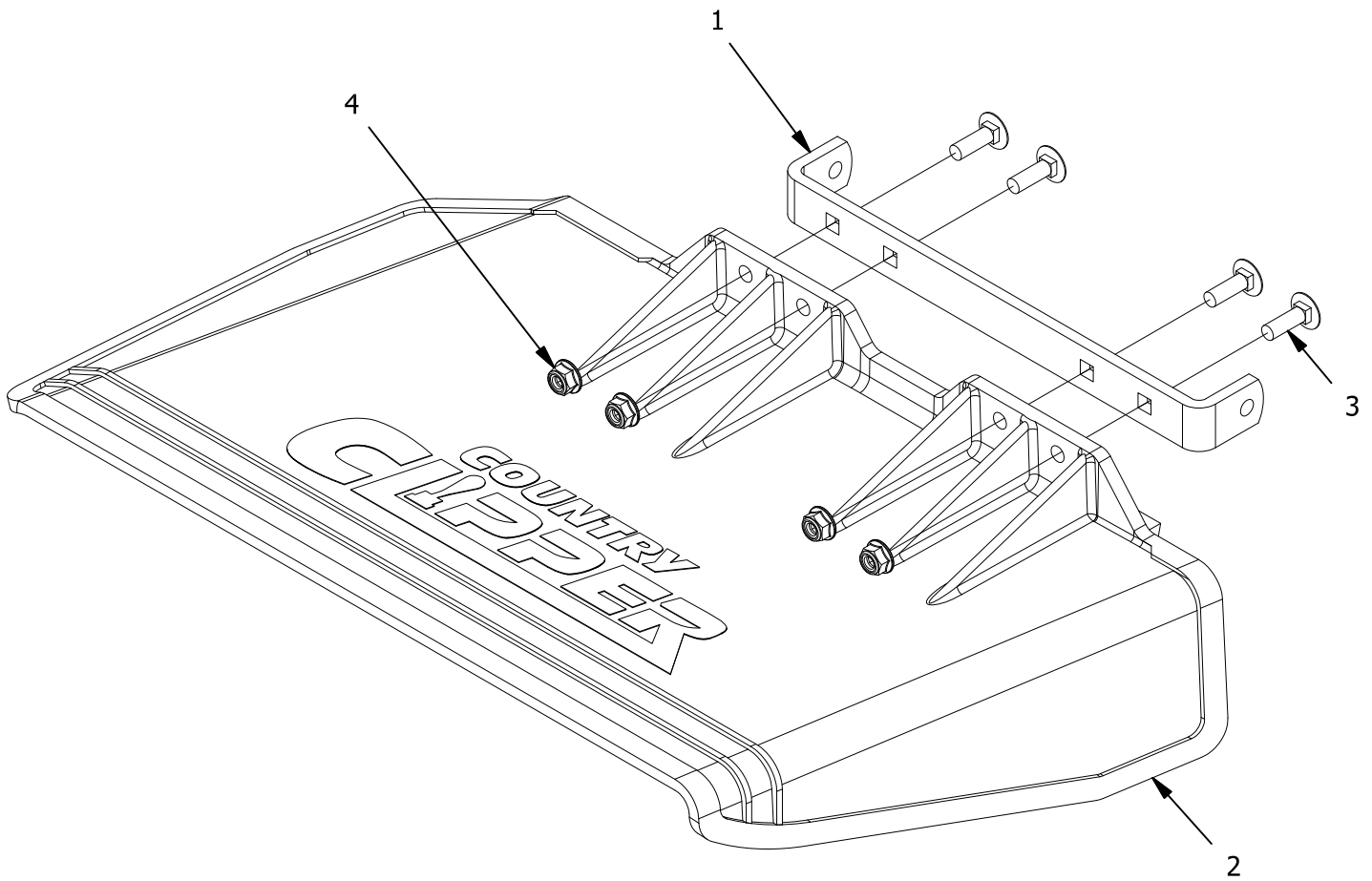

REF NO.	PART NO.	QTY.	DESCRIPTION
1	643-110P	1	CHUTE HINGE
2	H-2723	1	CHUTE, DISCHARGE, SMALL
3	F-2066	4	5/16-18 x 1" CARRIAGE BOLT,
4	F-2063	4	NUT, 5/16-18 NYLOC, FLANGED

LIFT HANDLE ASSEMBLY & RELATED PARTS

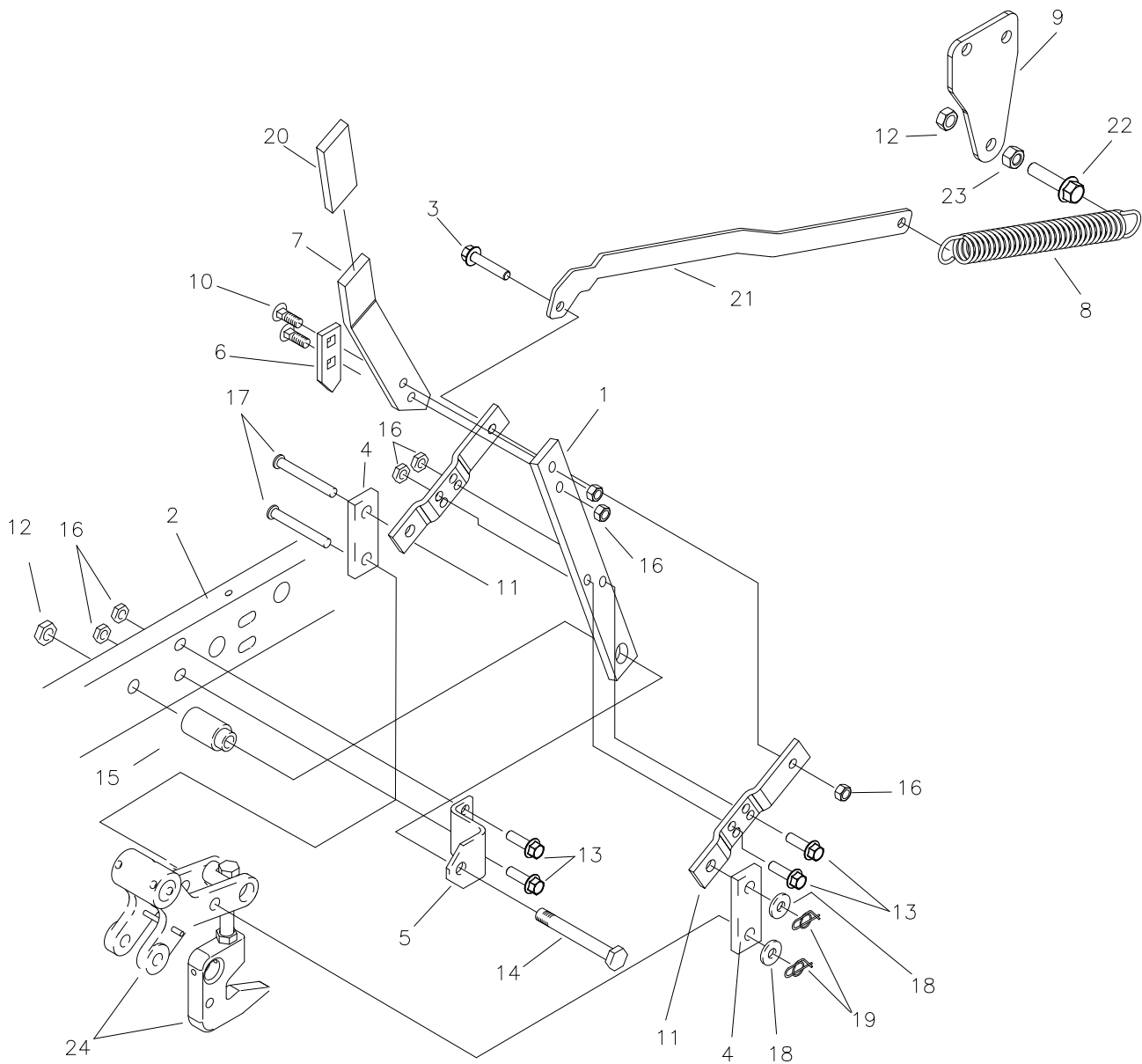

REF NO.	PART NO.	QTY.	DESCRIPTION	REF NO.	PART NO.	QTY.	DESCRIPTION
1	709-102P	1	LIFT HANDLE, LOWER	13	F-2125	4	FHCS, 1/2-13 X 1 1/4", YZ GR5
2	659-022W	1	FRAME WELDMENT, LH.	14	F-1439	1	1/2-13 X 3" GR. 5
3	F-2126	1	3/8-16 X 2" CAPSCREW	15	642-095P	1	HANDLE PIVOT PIN
4	642-061P	2	HANDLE LINK	16	F-2151	7	NUT, 3/8-16, NYLOC FLANGED
5	642-041P	1	HANDLE PIVOT BRACKET	17	F-1889	2	CLEVIS PIN, 1/2 X 2 5/8"
6	642-127P	1	TOP PEG LATCH PLATE	18	F-1521	2	1/2" FLAT WASHER
7	659-355P	1	LIFY HANDLE, UPPER	19	H-2239	2	RUE RING, 1/2"
8	H-1610	1	SPRING, 1 1/2" OD. X 8"	20	H-2324	1	VINYL GRIP, 3/8 X 1 1/2"
9	663-120P	1	PLT, SPRING MOUNT	21	663-080P	1	BAR, SPRING EXT.
10	F-1672	2	CARRIAGE BOLT, 3/8-16 X 1 1/4"	22	F-2128	1	FHCS, 1/2-13 X 2", YZ GR5
11	642-060P	2	SPRING ANCHOR PLATE	23	F-1011-05	7	HEX NUT, 1/2-13
12	F-2152	2	NUT, 1/2-13, NYLOC FLANGED	24	-----	-	SEE PAGE 7

LIFT ASSEMBLY & RELATED PARTS

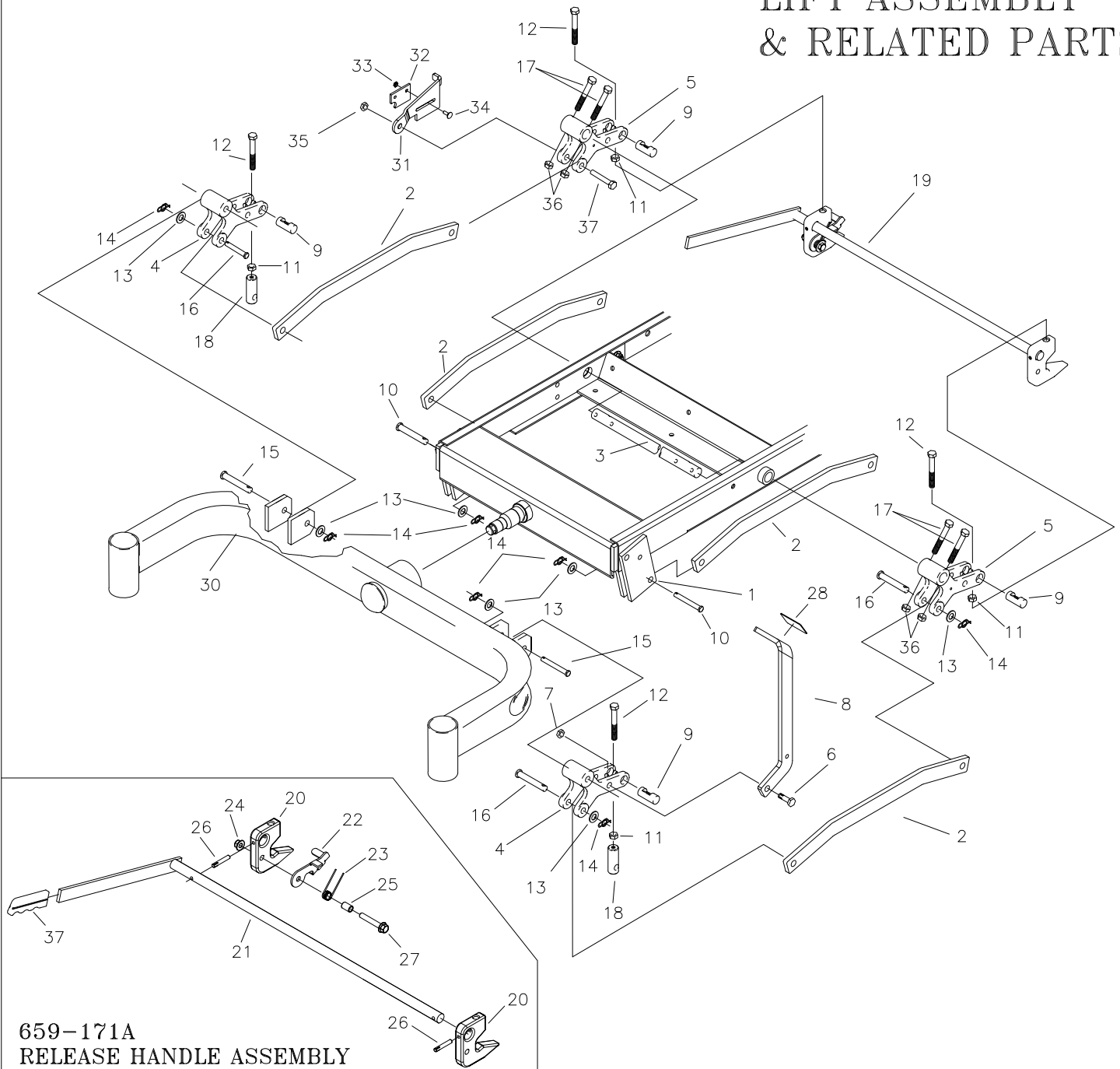

**659-171A
RELEASE HANDLE ASSEMBLY**

REF NO.	PART NO.	QTY.	DESCRIPTION	REF NO.	PART NO.	QTY.	DESCRIPTION
1	642-063P	2	DRAG BAR TAB	20	659-140P	2	DECK HOOK
2	659-299P	4	DRAG LINK BAR	21	659-148W	1	RELEASE HANDLE WELDMENT
3	620-051P	1	LIFT BAR	22	659-372P	1	HOOK KEEPER
4	642-081P	2	LIFT SLEEVE, FRONT	23	H-3011	1	SPRING, TORSION
5	642-193P	2	LIFT SLEEVE, REAR	24	F-2151	1	NUT, 3/8-16, NYLOC FLANGED
6	F-1879	1	5/16-18 X 1 1/4" GR.5	25	707-073P	1	SPACER
7	F-1125	1	5/16-18 STOVER NUT	26	F-2187	2	PIN, GROOVED, "C", 1/4 X 1.50"
8	659-056P	1	DECK LIFT PEDAL	27	F-2218	1	FHCS, 3/8-16X2-1/4", YZ, GR5
9	642-177P	4	HANGER PIN	28	H-2401	1	TREAD PAD
10	F-1815	2	CLEVIS PIN, 1/2 X 1 1/2"	29	H-1926	1	1/4"x1" HANDLE GRIP
11	F-1489	4	NUT, 1/2" JAM	30	642-189W	1	FRONT AXLE WELDMENT
12	F-1936	4	1/2-13 X 3 1/2, 2" THREAD	31	663-089P	1	LATCH PLATE
13	F-1521	7	WASHER, 1/2 NARROW	32	659-170P	1	PLATE, CATCH
14	H-2239	7	RUE RING, 1/2"	33	F-2132	2	NUT, 1/4-20, NYLOC FLANGED
15	F-1890	2	CLEVIS PIN, 1/2 X 3 1/2"	34	F-1823	2	CARRIAGE BOLT, 1/4-20 X 3/4"
16	F-1898	3	CLEVIS PIN, 1/2 X 2 3/4"	35	F-2152	1	NUT, 1/2-13, NYLOC FLANGED
17	F-2039	4	5/16-24 X 2" HHCS	36	F-2041	4	5/16-24 JAM NUT
18	642-175P	2	ADJUSTABLE HANGER END	37	F-1828	1	1/2-13 X 3-1/2" CAPSCREW
19	659-171A	1	RELEASE HANDLE ASSEMBLY				

TRANSMISSION IDLERS & RELATED PARTS

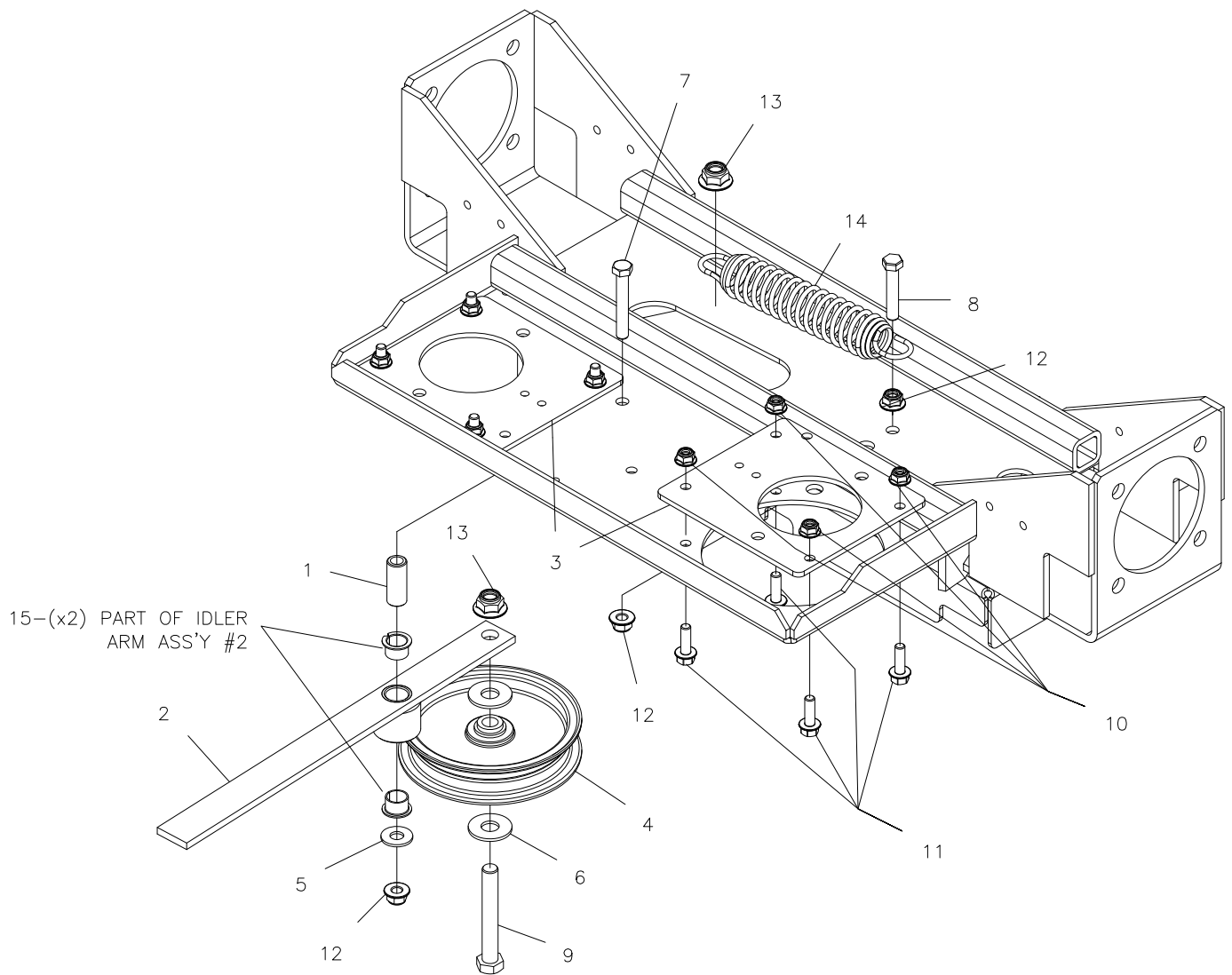

REF NO.	PART NO.	QTY.	DESCRIPTION	REF NO.	PART NO.	QTY.	DESCRIPTION
1	659-085P	1	Mounting Pin	9	F-1936	5	1/2-13 x 3-1/2" Capscrew
2	663-057A	1	Hydro Idler Arm Assembly	10	F-2063	66	Nut, 5/16-18 Nyloc, Flanged
3	663-146P	2	PLATE, PUMP ADAPTER	11	F-2148	10	FHCS, 5/16-18 x 1.00, YZ, GR5
4	D-3904	1	PULLEY, FLAT IDLER, 5"	12	F-2151	25	Nut, 3/8-16 Nyloc, Flanged
5	F-1009-03	2	3/8" Flat Washer	13	F-2152	31	Nut, 1/2-13 Nyloc, Flanged
6	F-1009-05	2	1/2" FLAT WASHER	14	H-2619	1	SPRING, 5 X 1-1/2, TAPERED ENDS
7	F-1015-30	1	3/8-16 x 2-1/2" Capscrew	15	D-3730	2	FLANGED BUSHING
8	F-1073	1	3/8-16 x 2" Capscrew				

CASTER WHEEL ASSEMBLY

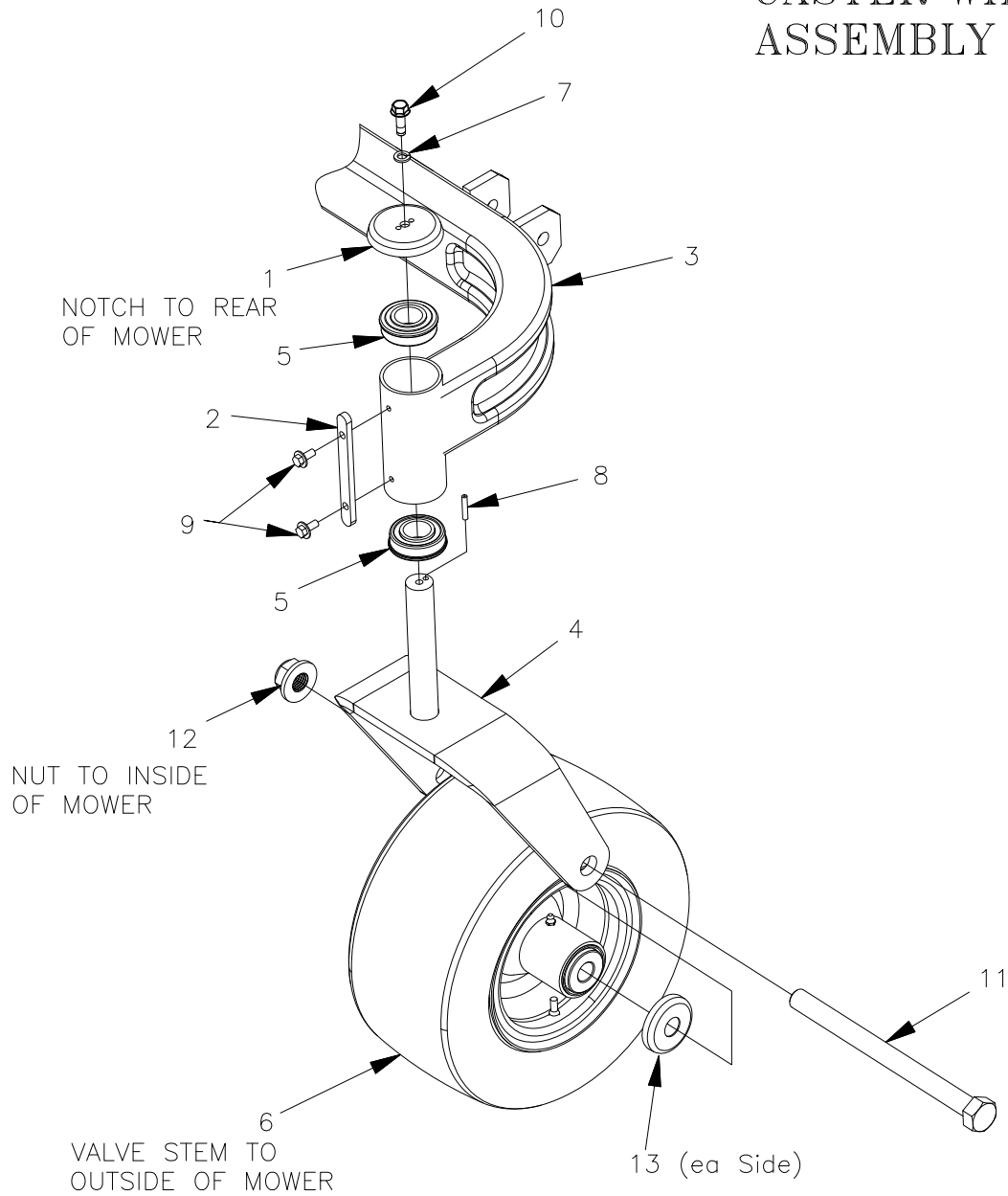

REF NO.	PART NO.	QTY.	DESCRIPTION	REF NO.	PART NO.	QTY.	DESCRIPTION
1	636-176P	2	Bearing Cap	8	F-1855	2	3/16 x 1" Roll Pin (Heavy Duty)
2	659-185P	2	Stop Tab	9	F-2030	4	1/4 x 5/8 Self Tapping Capscrew
3	659-287W	1	WLDT, AXLE, FRONT	10	F-2121	10	FHCS, 5/16-18x1.00, YZ, LOCK PATCH, GR5
4	663-217W	2	WLD'T, CASTER YOKE	11	F-2194	2	HHCS, 3/4-10 X 9-1/2", YZ, GR5
5	D-2008-02	4	Bearing SF-16-32	12	F-2195	2	NUT, FLANGE NYLOC, YZ
6	D-3936	2	TIRE ASS'Y, WHITE, SMOOTH, 13X6.5-6	13	663-221P	2	CAP FOR BEARINGS
7	F-1019-02	2	5/16" LockWasher				

FRAME SIDES & RELATED PARTS

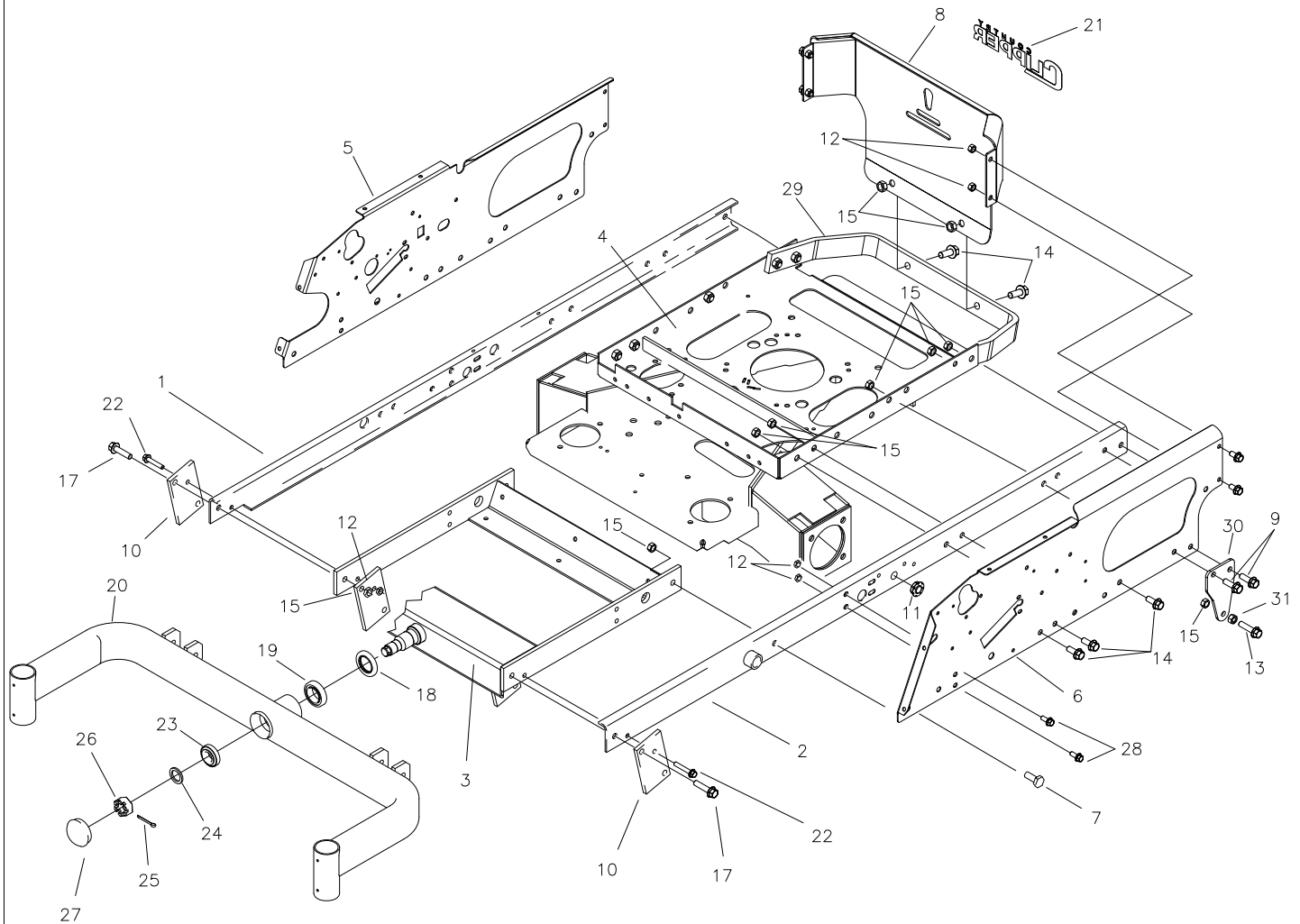

REF NO.	PART NO.	QTY.	DESCRIPTION	REF NO.	PART NO.	QTY.	DESCRIPTION
1	663-185W	1	FRAME SIDE RH.	16	F-2124	4	FHCS, 3/8-16 X 3/4" GR.5
2	663-187W	1	FRAME SIDE LH.	17	F-2128	2	FHCS, 1/2-13 X 2", GR.5
3	709-157W	1	AXLE MOUNTING WLDT.	18	H-2812	1	SEAL SHAFT
4	663-176W	1	MOTOR MOUNT WLDT.	19	D-3825	1	BEARING, TAPARED SET
5	663-188P	1	SIDE PANEL RH. (JOYSTICK)	20	642-189W	1	FRONT AXLE WELDMENT
-	663-195P	1	SIDE PANEL RH. (TWINSTICK)	21	P-13312	1	DECAL, LOGO, CHROME w/BLK, LG
6	663-189P	1	SIDE PANEL LH. (JOYSTICK)	22	F-2126	2	FHCS, 3/8-16 x 2" GR.5
-	663-196P	1	SIDE PANEL LH. (TWINSTICK)	23	D-3826	1	BEARING, TAPARED SET
7	F-1386	2	1/2-13 X 1-1/4" GR.5	24	606-303P	1	1" WASHER
8	707-098A	1	ENGINE GUARD w/DECAL	25	F-1728	1	3/16 X 2" COTTER PIN
9	F-2140	4	FHCS, 1/2-13 x 1-1/2" GR.5	26	F-1724	1	1-14 SLOTTED NUT
10	642-063P	2	DRAG BAR TAB	27	H-1924	1	GREASE CAP
11	H-2773	2	BEARING, FLG-SPHERICAL, IGUS	28	F-2125	4	FHCS, 3/8-16 x 1-1/4", YZ, GR5
12	F-2151	10	NUT, 3/8-16, NYLOC FLANGED	29	707-003P	1	GUARD, BUMPER
13	F-2128	1	FHCS, 1/2-13 x 2 GR.5	30	663-120P	1	PLATE, SPRING MOUNT
14	F-2127	15	FHCS, 1/2-13 X 1-1/4" GR.5	31	F-1011-05	1	HEX NUT, 1/2-13
15	F-2152	18	NUT, 1/2-13, NYLOC FLANGED				

FENDER ASSEMBLY & RELATED PARTS

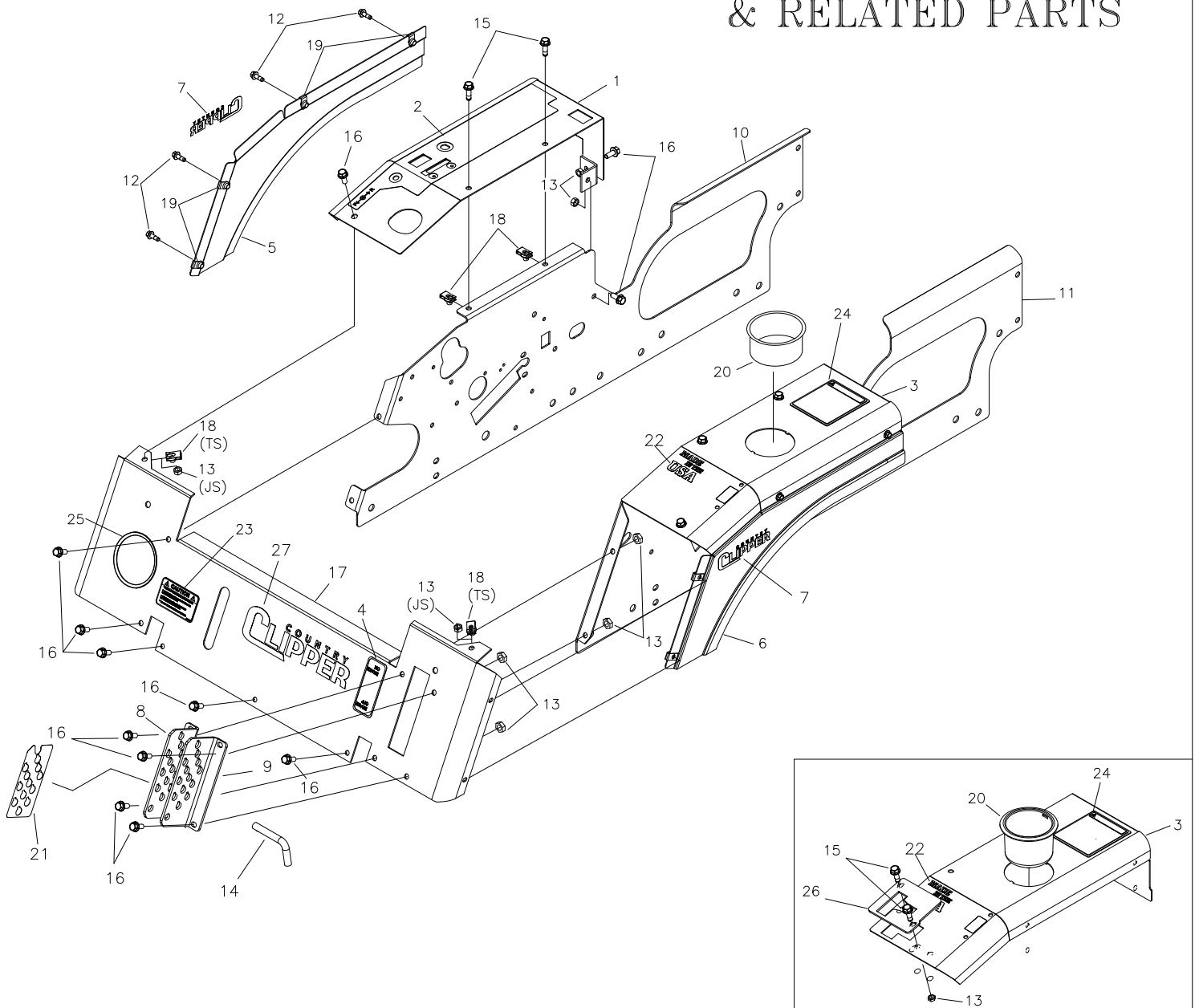

TWINSTICK FENDER ASSY

REF NO.	PART NO.	QTY.	DESCRIPTION	REF NO.	PART NO.	QTY.	DESCRIPTION
1	629-840A	1	FENDER CAP w/DECAL, RH, (JS)	12	F-2119	8	FHCS, 1/4-20x3/4", GR.5 w/PATCH
-	629-892A	1	FENDER CAP w/DECAL, EFI, RH, (JS)	13	F-1125	13	5/16-18 LOCK NUT
-	629-842A	1	FENDER CAP w/DECAL, RH, (TS)	14	H-3013	1	DECK HEIGHT PIN
-	629-893A	1	FENDER CAP w/DECAL, EFI, RH, (TS)	15	F-2121	8	FHCS, 5/16-18x1" GR.5 w/PATCH
2	P-12925	1	DECAL, CONTROL PANEL	16	F-2120	15	FHCS, 5/16-18 X 3/4" GR.5
-	P-13172	1	DECAL, CONTROL PANEL, EFI	17	707-107A	1	FRONT PANEL w/DECALS
3	629-841A	1	FENDER CAP w/DECAL, LH (JS)	18	F-1860	6	5/16-18 "U"-NUT
-	629-843A	1	FENDER CAP w/DECAL, LH (TS)	19	F-1858	8	1/4-20 "U"-NUT
4	P-11382	1	DECAL, PARK BRAKE	20	H-2228	1	CUP HOLDER
5	629-890A	1	FENDER SKIRT w/DECAL, RH	21	P-13325	1	DECAL, DECK LIFT
6	629-891A	1	FENDER SKIRT w/DECAL, LH	22	P-13000	1	DECAL, "USA"
7	P-13311	2	DECAL, LOGO, CHROME w/BLK, SM	23	P-12557	1	DECAL, "CAUTION"
8	647-259A	1	LATCH PLATE RH W/DECAL	24	P-11370	1	DECAL, WARNING
9	647-258P	1	LATCH PLATE LH.	25	H-1626	1	U CHANNEL TRIM
10	-----	1	SEE PAGE 11	26	659-262P	1	NEUTRAL PLATE
11	-----	1	SEE PAGE 11	27	P-13312	1	DECAL, LOGO, CHROME w/BLK, LG

SEAT, FOOTDECK & RELATED PARTS

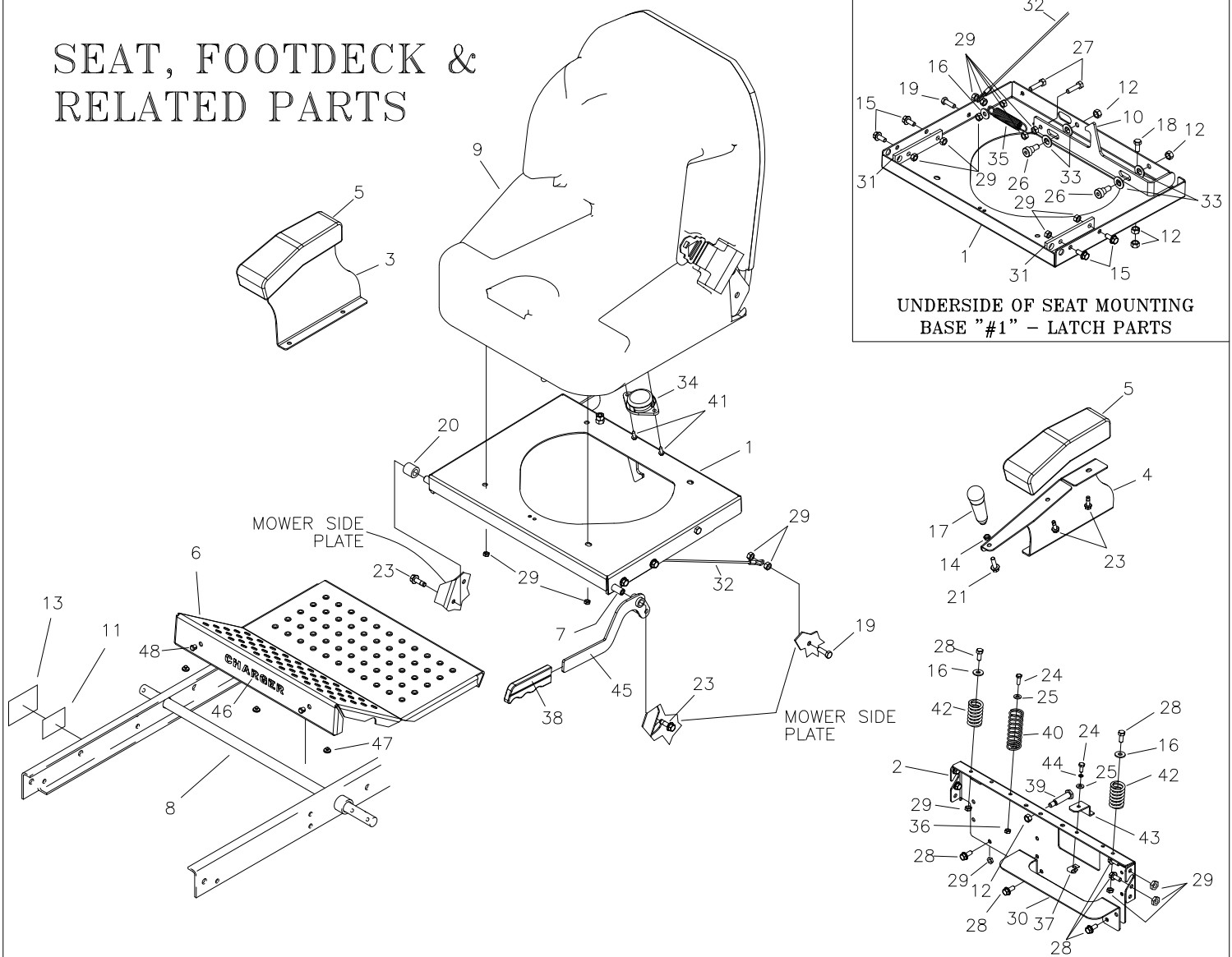

REF NO.	PART NO.	QTY.	DESCRIPTION	REF NO.	PART NO.	QTY.	DESCRIPTION
1	663-194P	1	PLATE, SEAT	24	F-2162	1	FHCS, 1/4-20 X 3/4", GR5, YZ
2	663-197P	1	PLT, REAR SEAT FILLER	25	F-1009-01	2	1/4" FLAT WASHER
3	707-047P	1	PLATE, ARM REST RH	26	F-2062	2	1/2"x3/8 SHOULDER BOLT, SOCKET
4	707-070P	1	PLATE, ARM REST LH (JOYSTICK)	27	F-2122	2	FHCS, 5/16-18 X 1-1/4 YZ, GR5
-	707-048P	1	PLATE, ARM REST LH (TWINSTICK)	28	F-2120	10	FHCS, 5/16-18x3/4" GR5
5	H-2763	2	PAD, ARM REST	29	F-2063	20	NUT, 5/16-18, NYLOC FLANGED
6	629-846A	1	FOOT DECK w/DECAL, CHARGER	30	707-066P	1	SHELF, REAR, FUEL TANK
7	707-043P	1	PIN, SEAT HINGE	31	707-045P	2	BAR, REINFORCEMENT, SEAT
8	620-051P	1	LIFT BAR	32	H-2460	1	CABLE
9	H-2755	1	SEAT	33	F-1521	4	1/2" WASHER
-	H-2910	1	COVER FOR SEAT H-2755	34	E-6347	1	SEAT SWITCH
10	663-081P	1	PLATE, LATCH SLIDE LONG	35	H-1635	1	3/4x4" EXTENSION SPRING
11	P-13142	1	SERIAL TAG	36	F-2132	1	NUT, 1/4-20, NYLOC FLANGED
12	F-1005-03	7	3/8-16 LOCK NUT	37	F-1858	1	1/4-20 "U" NUT
13	P-12473	1	SERIAL TAG LAMINATION DECAL	38	H-1926	1	HANDLE, GRIP
14	F-1486	1	3/8-16 JAM NUT	39	F-2061	1	1/2"x1 1/2" SHOULDER BOLT
15	F-2120	4	FHCS, 5/16-18x3/4" GR5	40	H-2608	1	SPRING, ASSIST
16	F-1009-02	3	5/16 FLAT WASHER	41	F-1785	2	SCREW, HX WASHER HD #14 X 3/4"
17	H-2764	1	HANDLE, JOYSTICK	42	H-2636	2	SPRING, CMPR, SEAT CHARGER
18	F-2141	1	FHCS, 3/8-16 X 1", YZ, GR5	43	659-137P	1	BATTERY HOLD DOWN
19	F-2148	2	FHCS, 5/16-18 X 1" YZ GR5	44	F-1019-01	1	1/4" LOCK WASHER
20	707-046P	1	SPACER, SEAT PAN	45	663-205W	1	WLDT, BRAKE HANDLE
21	F-2125	1	FHCS, 5/16-18x1-1/4" GR5	46	P-13317	1	DECAL, CHARGER
22	F-2063	4	3/8-16 NYLOC NUT, FLANGED	47	H-2461	3	RUBBER BUMPER
23	F-2121	6	FHCS 5/16-18x1" w/PATCH	48	H-1280	2	PLASTIC PLUG

FRONT STEP ASSEMBLY

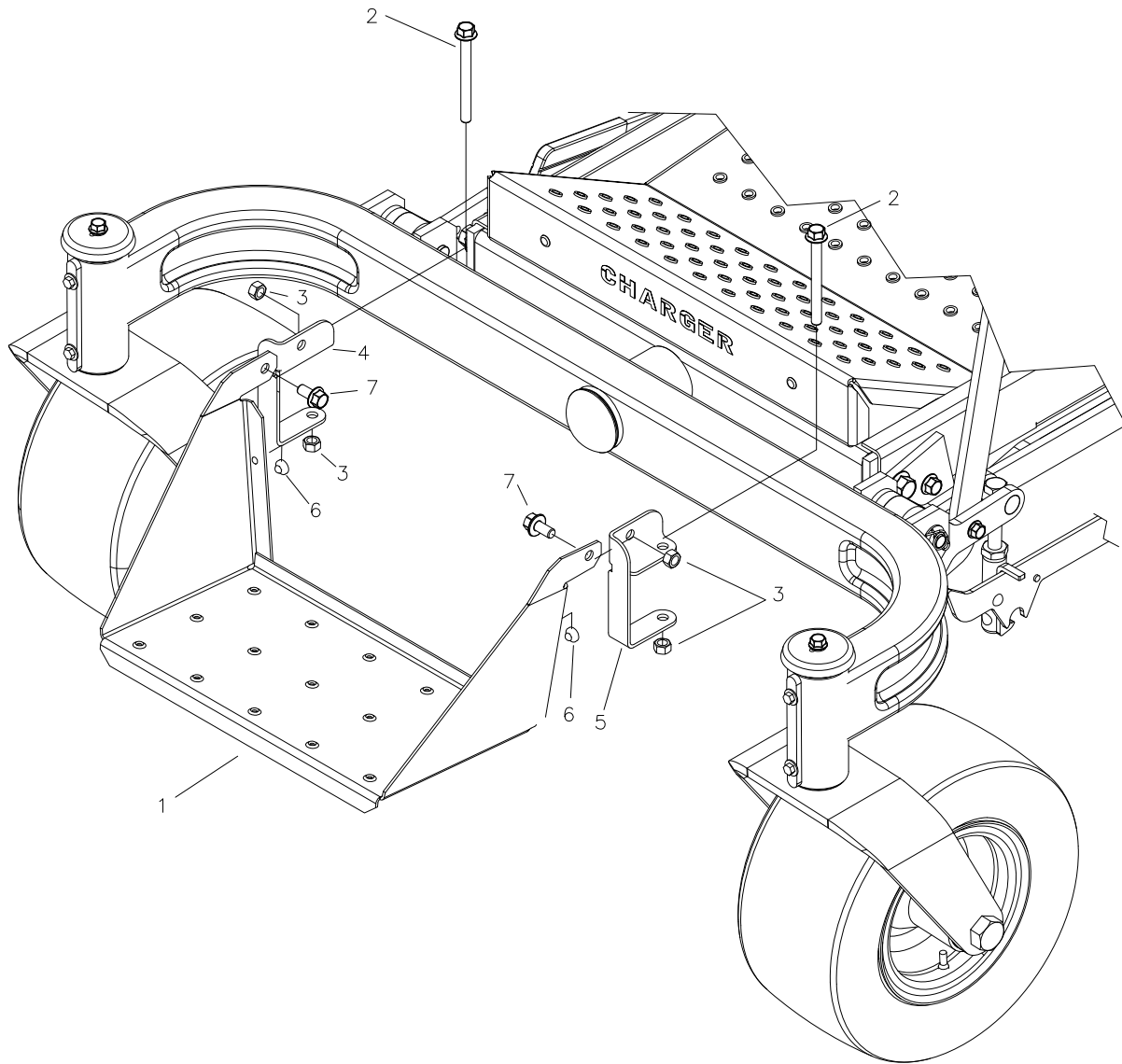

REF NO.	PART NO.	QTY.	DESCRIPTION
1	663-134P	1	FRONT STEP
2	F-2142	2	FHCS, 3/8-16 X 4" GR.5
3	F-2151	4	NUT, 3/8-16, NYLOC FLANGED
4	659-241P	1	BRACKET, STEP MOUNT, RH
5	659-242P	1	BRACKET, STEP MOUNT, LH
6	H-2461	2	RUBBER BUMPER BUTTON
7	F-2124	2	FHCS, 3/8-16 X 3/4" GR.5

ROPS ASSEMBLY (H-2682) AND RELATED PARTS

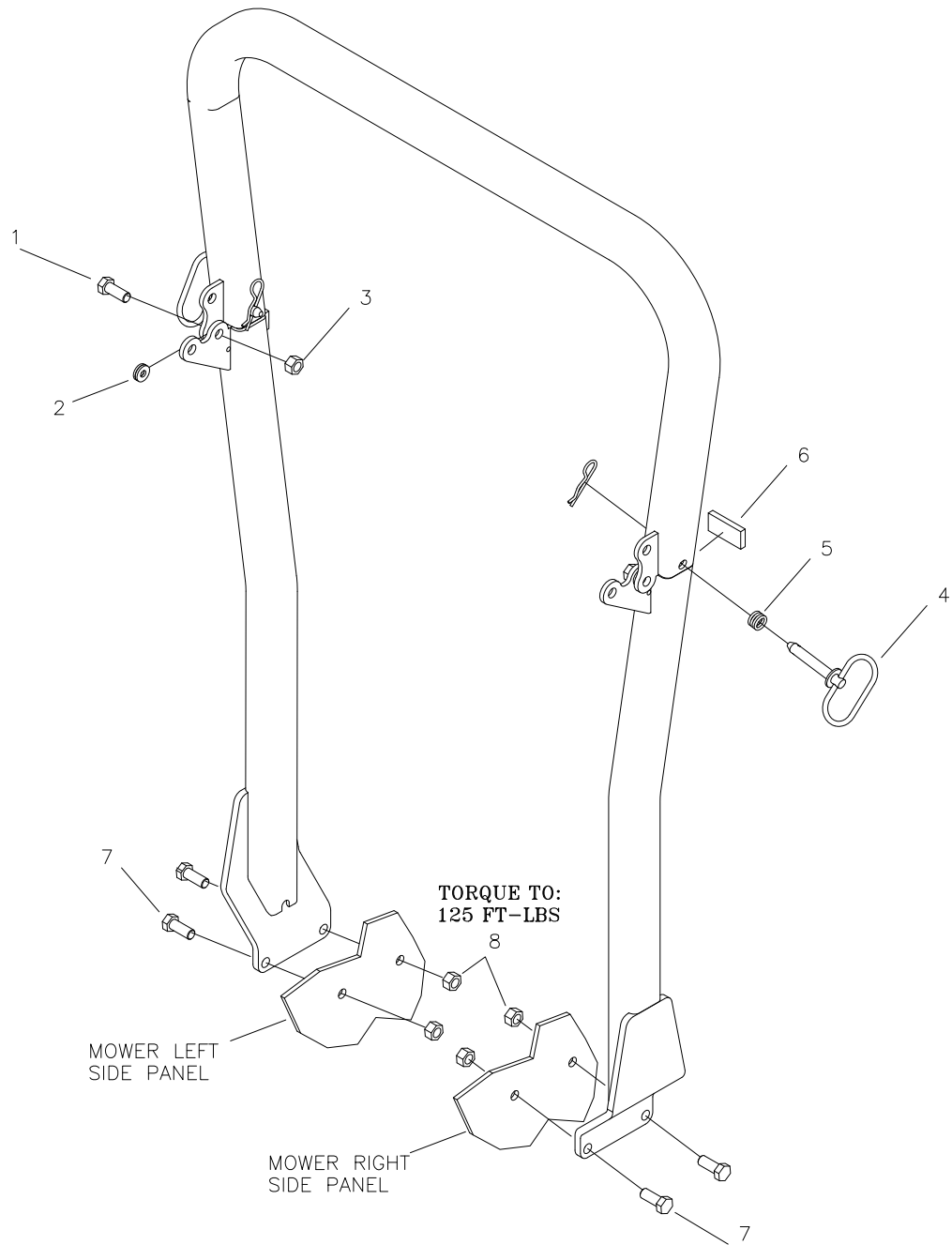

REF NO.	PART NO.	QTY.	DESCRIPTION
1	F-2088	2	HHCS 1/2-13 x 1 1/4"
2	F-2089	2	FLAT WASHER 1/2"φ
3	F-2090	2	TOP LOCK NUT 1/2"φ
4	F-2093	2	PULL PIN-1/2 W/COTTER KEY
5	H-2701	2	SPRING
6	H-2700	2	POLYURETHANE CHANNEL
7	F-2091	4	HHCS 1/2-13 x 1 1/2"
8	F-2092	4	NLN 1/2-13 GR 8

FUEL TANK ASSEMBLY H-2944

(INCLUDES ALL PARTS EXCEPT #6-10)

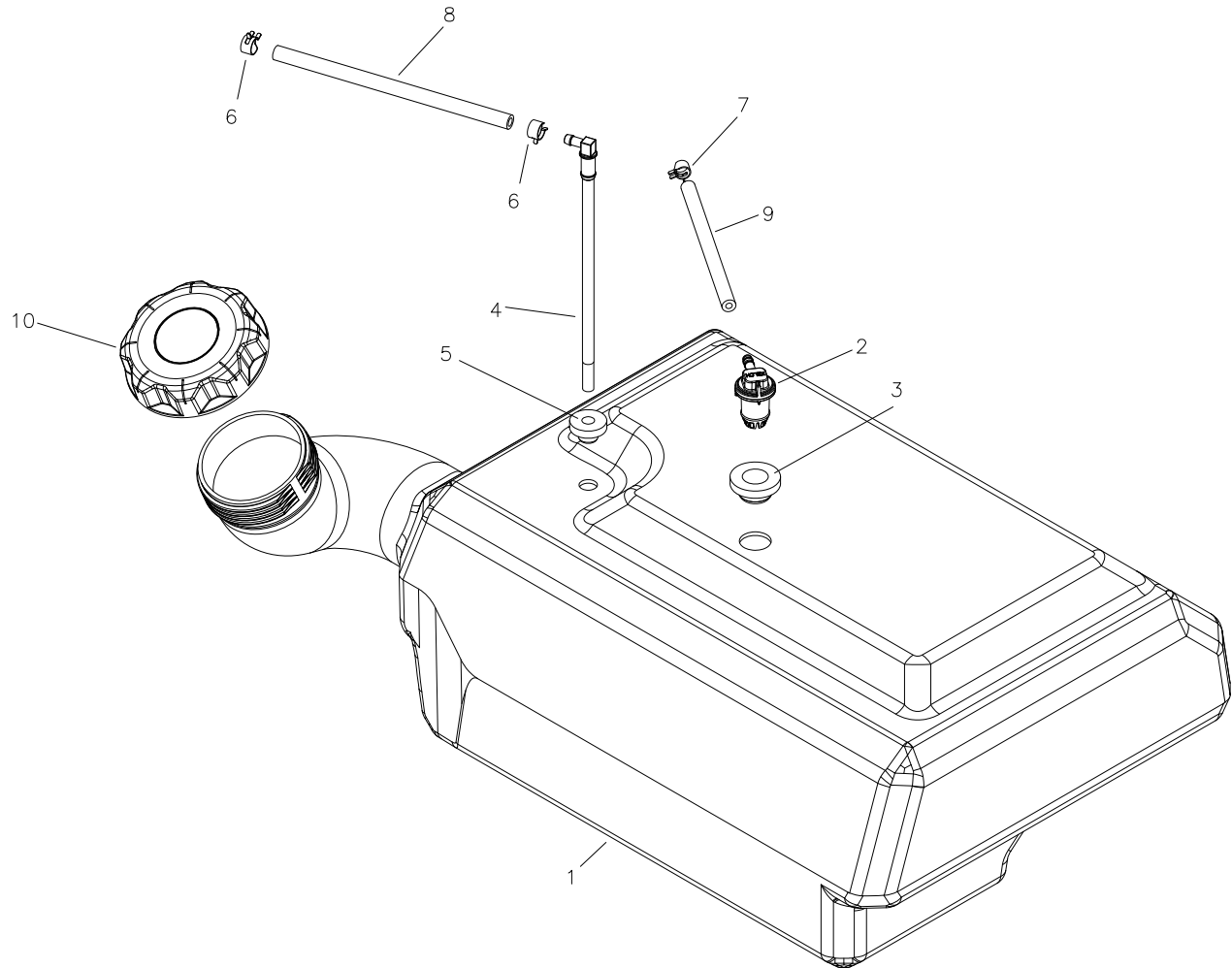

REF NO.	PART NO.	QTY.	DESCRIPTION
1	-----	-	7 GALLON TANK, VENTED
2	H-2678	1	REMOTE VENT
3	H-2679	1	REMOTE VENT GROMMET
4	H-2742	1	PICK UP TUBE
5	H-2741	1	GROMMET, PICK UP TUBE
6	H-1687	2	HOSE CLAMP, 1/2"
7	H-2698	2	VENT LINE CLAMP
8	H-1648	4.0ft	FUEL LINE
9	H-2697	4.0ft	VENT LINE
10	H-2743	1	GAS CAP, RATCHET

JOYSTICK STEERING CONTROL AND RELATED PARTS

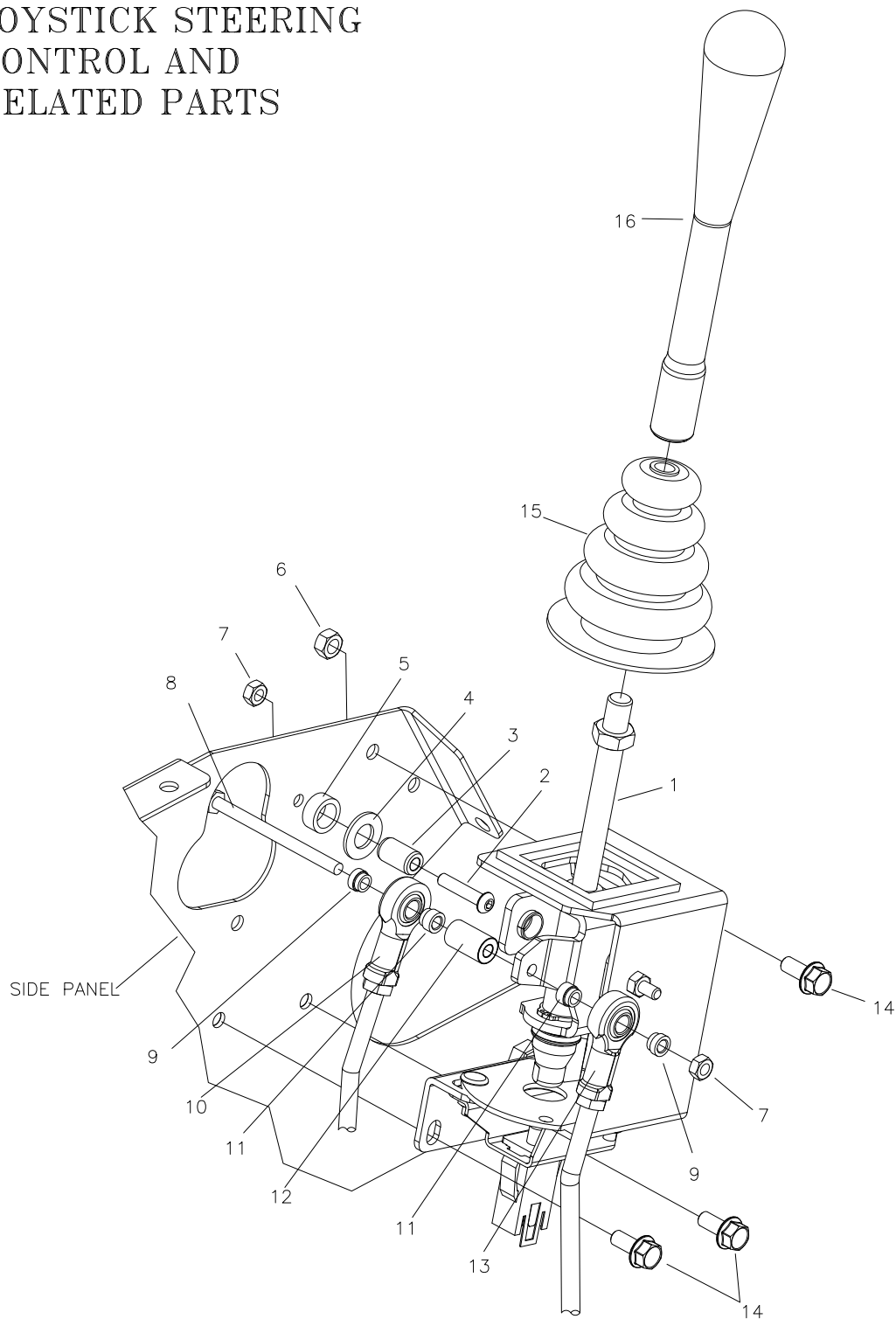

REF NO.	PART NO.	QTY.	DESCRIPTION	REF NO.	PART NO.	QTY.	DESCRIPTION
1	625-172A	1	JOYSTICK ASSEMBLY	10	707-082P	1	LINKAGE, INNER, JOYSTICK
2	F-2103	1	BUTTON SHCS, 1/4-20x1"	11	625-107P	1	BUSHING, .375 ROD END
3	625-119P	1	PIN, PIVOT, JS, LONG	12	625-100P	1	TUBE, PIVOT, JOYSTICK
4	F-1521	1	1/2" WASHER	13	707-083P	1	OUTER, LINKAGE, JOYSTICK
5	625-126P	1	SPACER, JOYSTICK PANEL	14	F-2120	3	FHCS, 5/16-18 x 3/4" GR5
6	F-2063	3	NUT, 5/16-18, NYLOC FLANGED	15	H-1991	1	BOOT
7	F-2132	2	NUT, 1/4-20, NYLOC FLANGED	16	H-2764	1	HANDLE, JOYSTICK
8	F-1020-01	1	1/4-20 x 3-1/2" CAPSCREW				
9	625-116P	1	BUSHING, .375 ROD END, SHORT				

JOYSTICK ASSEMBLY 625-172A

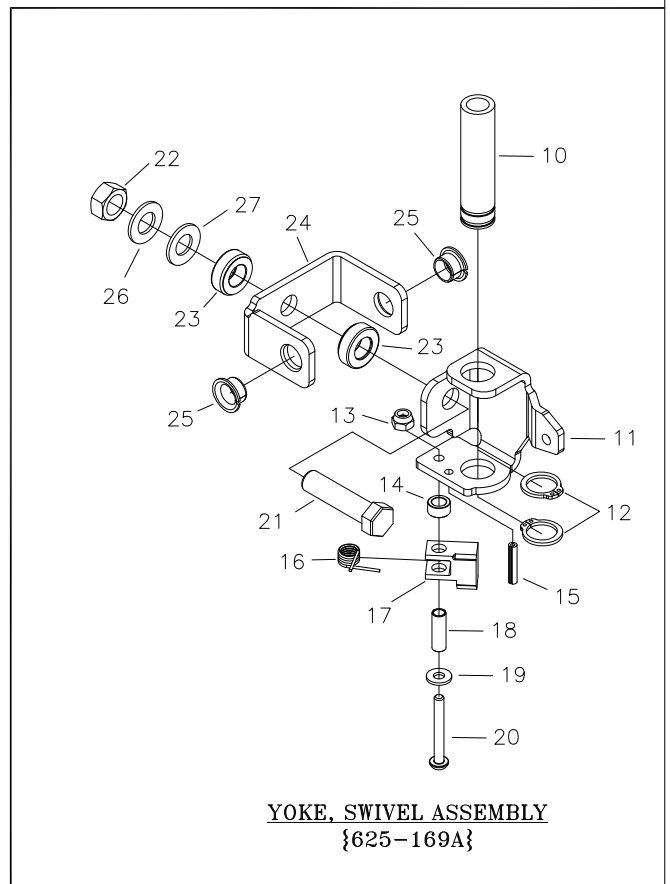
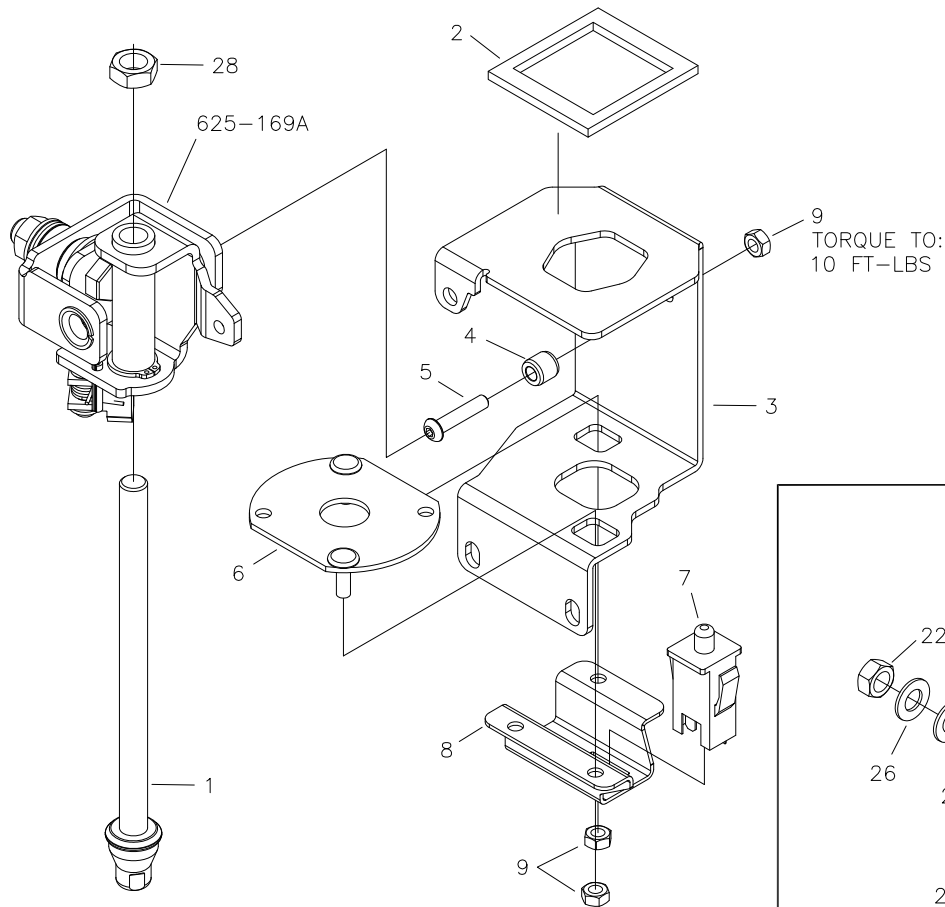

ITEM	PART #	QTY.	DESCRIPTION	ITEM	PART #	QTY.	DESCRIPTION
1	709-169A	1	ROD ASSEMBLY, SHORT	15	F-1503	1	3/16 x 1" SPIRAL PIN
2	H-1947	1	GASKET, FOAM, JOYSTICK	16	H-2710	1	SPRING, DETENT, JOYSTICK
3	625-095P	1	HOUSING, JOYSTICK	17	625-103P	1	TAB, CAM DETENT
4	625-106P	1	PIN, PIVOT, JOYSTICK	18	625-124P	1	TUBE-SPACER, DETENT CAM
5	F-2103	1	BUTTON SHCS, 1/4-20 x 1", CZ	19	F-2136	1	WASHER, FLAT, #12 PLAIN
6	625-127W	1	NEUTRAL PLATE, WLDT	20	F-2135	1	SCR, PANHD, PHLPS, #12-24x1-3/4"
7	E-6474	1	SWITCH, SNAP MOUNT	21	F-1293	1	1/2-13 x 2" CAPSCREW
8	659-285P	1	MOUNT, SWITCH	22	F-1005-05	1	1/2-13 STOVER NUT
9	F-1005-01	3	1/4-20 LOCK NUT	23	D-3931	2	THRUST BEARING
10	625-099P	1	TUBE, GUIDE, CONTROL ROD	24	625-097P	1	PIVOT, JOYSTICK (PART OF 625-128A)
11	625-096P	1	YOKE, SWIVEL, JOYSTICK	25	D-3784	2	BUSHING, FLANGED (PART OF 625-128A)
12	H-2705	2	RING, DETENT, .75 EXT.	26	F-1521	1	1/2" WASHER, CUSTOM
13	F-2137	1	NUT, #12-24, NYLOCK	27	H-2704	1	SPRING, BELLEVILLE, .50x1x.073
14	625-125P	1	SPACER, CAM DETENT	28	F-1462	1	NUT, JAM, 1/2-20, CZ

JOYSTICK STEERING CONTROL AND RELATED PARTS (CON'T)

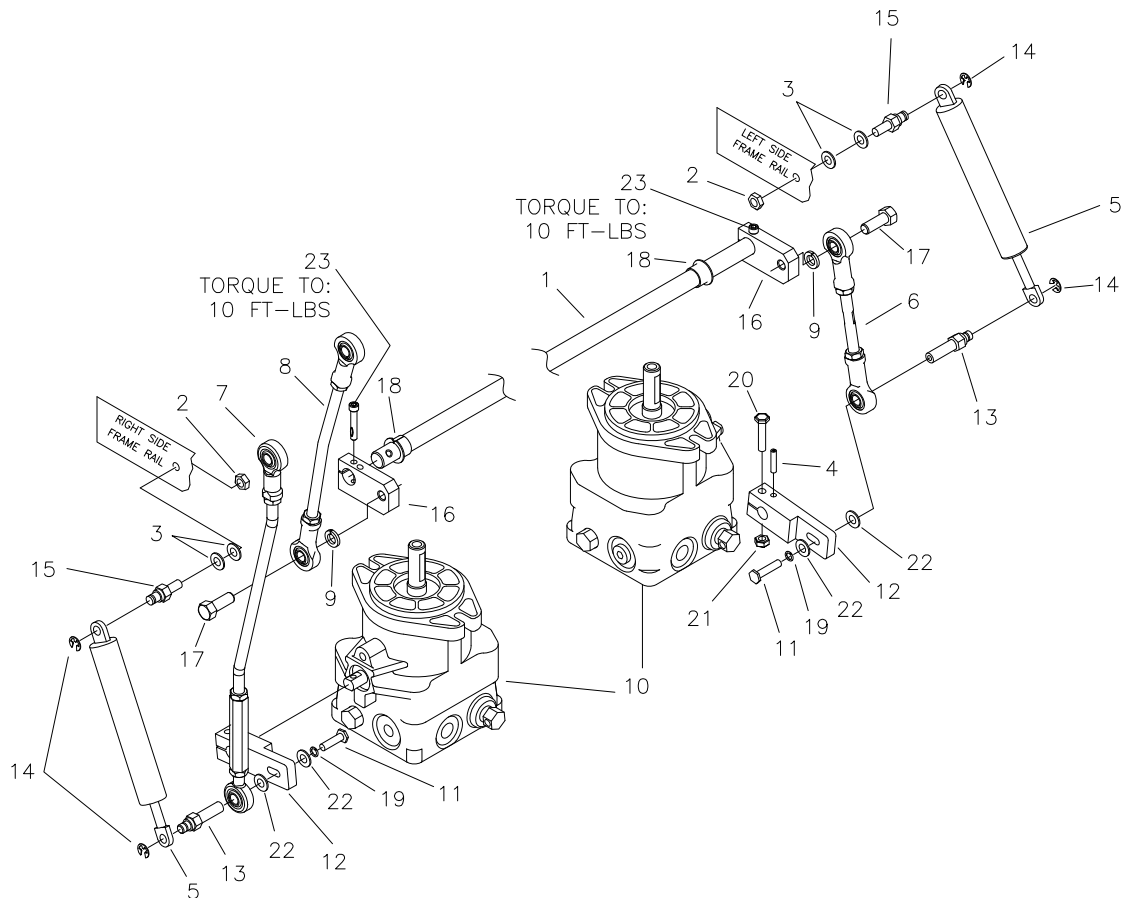

REF NO.	PART NO.	QTY.	DESCRIPTION	REF NO.	PART NO.	QTY.	DESCRIPTION
1	700-150P	1	HYDRO SHIFT ROD	13	663-051P	2	DAMPNER BOLT, FEMALE
2	F-2063	2	NUT, 5/16", NYLOC FLANGED	14	F-1610	4	E-RING
3	F-1009-02	4	5/16" FLAT WASHER	15	638-028P	4	5/16-18 X 3/4" DAMPNER BOLT
4	F-1725	2	5MM x 26MM ROLL PIN	16	700-151P	2	SWIVEL ARM
5	H-2467	2	DUAL ACTION DAMPER, LITE DUTY	17	F-1394	2	3/8-16 X 1" CAPSCREW
6	H-2468	1	LINKAGE, JOYSTICK	18	D-3730	2	BUSHING
7	707-083P	1	OUTER, LINKAGE, JS	19	F-1019-01	2	1/4" LOCK WASHER
8	707-082P	1	LINKAGE, INNER, JS	20	F-1539	2	1/4-20 x 1 1/4" CAPSCREW
9	F-1019-03	2	3/8" LOCK WASHER	21	F-1158	2	1/4-20 STOVER NUT
10	----	-	SEE PAGES 23 & 24	22	F-1009-01	4	1/4" FLAT WASHER
11	F-1015-05	2	1/4-20 X 1" BOLT GR 5	23	F-2131	2	SHCS, 12-24X1-1/4, YZ, LOCK PATCH
12	663-135P	2	LEVER, CONTROL				

TWINSTICK STEERING CONTROL & RELATED PARTS

(RIGHTHAND SHOWN, LEFTHAND OPPOSITE)

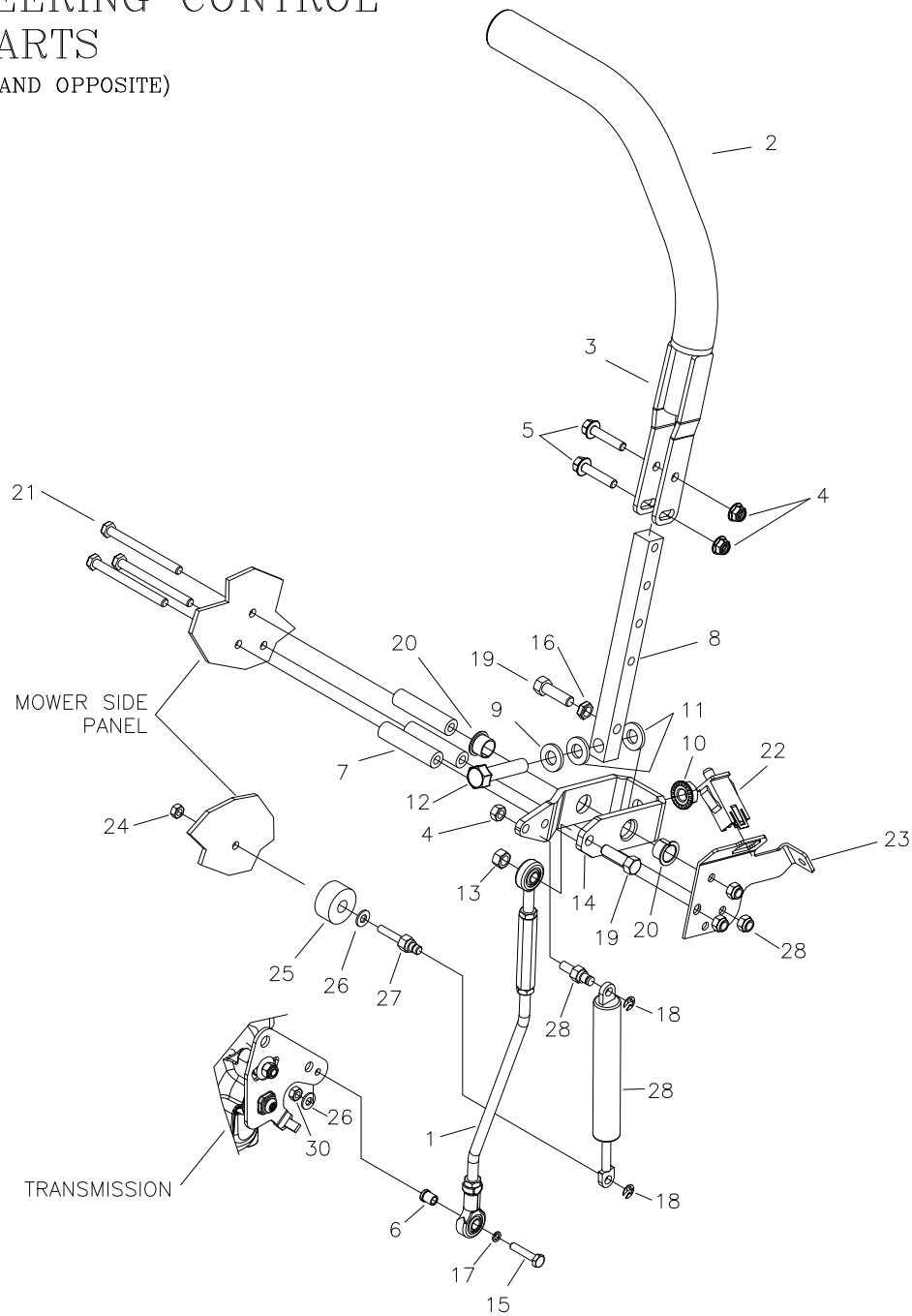

REF NO.	PART NO.	QTY.	DESCRIPTION	REF NO.	PART NO.	QTY.	DESCRIPTION
1	663-050P	1	LINK ROD ASSEMBLY	16	F-1486	1	3/8-16 JAM NUT
2	H-2739	1	GRIP, 15", CLOSED END	17	F-1019-01	4	1/4" LOCK WASHER
3	659-364W	1	DUAL LEVER CONTROL	18	F-1610	2	E-RING FOR 1/4" SHAFT
4	F-2063	8	NUT, 5/16-18, NYLOC FLANGED	19	F-1307	2	3/8-16 X 1 1/4" CAPSCREW
5	F-2129	2	FHCS, 5/16-18 X 1 1/2" w/PATCH	20	D-3730	2	FLANGED BUSHING 5/8" BORE
6	H-2465	1	ADAPTER, ROD END, LONG	21	F-2058	3	5/16-18 X 3 1/2" CAPSCREW
7	659-252P	3	TUBE SPACER	22	E-6474	1	SWITCH, SNAP MOUNT
8	659-365P	1	LOWER SHIFT BLOCK	23	647-242P	1	MOUNTING BRACKET (RH)
9	F-1521	1	WASHER	--	647-243P	1	MOUNTING BRACKET (LH)
10	F-2060	1	1/2-13 NUT, FLANGE LOCK	24	F-2132	1	NUT, 1/4-20, NYLOC FLANGED
11	606-151P	2	WASHER, NYLON 1/2 ID X 1/8"	25	F-2045	1	SPACER
12	F-1293	1	HHCS, 1/2-13 X 2", YZ GR5	26	F-1009-01	2	1/4" FLAT WASHER
13	F-2151	1	NUT, 3/8-16, NYLOC FLANGED	27	638-029P	1	DAMPER BOLT, 1/4-20
14	659-243P	1	SHIFTING YOKE	28	H-2843	1	DUAL ACTION DAMPNER, 750N
15	F-2182	1	FHCS, 1/4-20 X 1-1/4", YZ GR5	29	638-028P	1	DAMPER BOLT, 5/16-18 X 3/4"

GEAR MOTOR, WHEEL ASSEMBLY

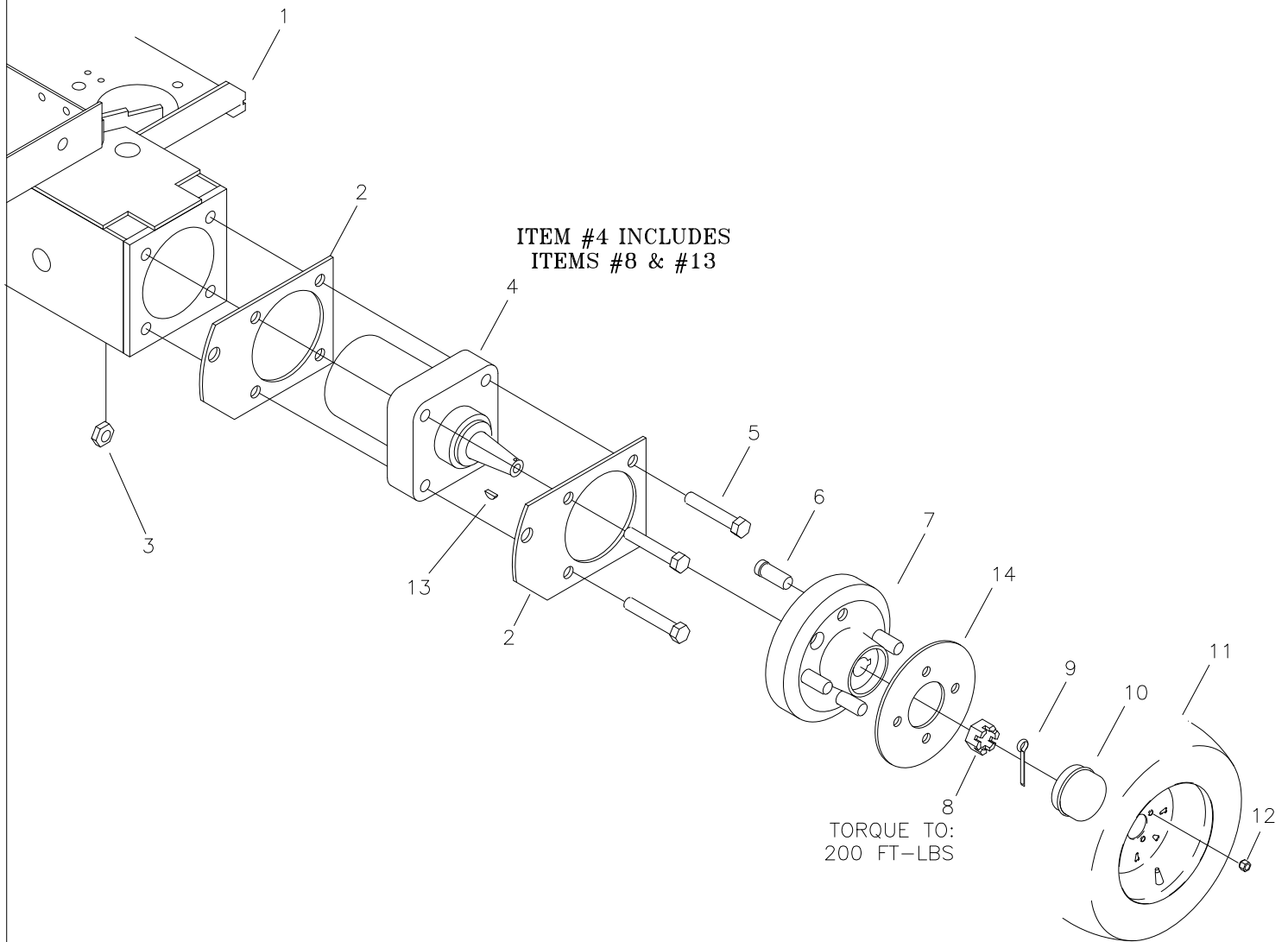

REF NO.	PART NO.	QTY.	DESCRIPTION
1	663-176W	1	MOTOR MOUNT
2	647-017P	4	BRAKE MOUNT
3	F-2152	8	NUT, 1/2-13, NYLOC FLANGED
4	D-3908	2	15.9 CIR PARKER WHEEL MOTOR
5	F-1668	8	1/2-13 X 2 3/4" BOLT GR. 5
6	F-1654	8	WHEEL STUD (REPLACEMENT)
7	663-207A	2	WHEEL HUB
8	F-1909	2	3/4-16 CASTLE NUT
9	H-1376	2	1/8 X 1 1/2" COTTER PIN
10	H-1798	1	GREASE CAP
11	D-3669	2	TIRE/WHEEL ASSEMBLY
12	F-1499	8	LUG NUT 1/2-20 X 60 DEG.
13	D-1004-01	2	1/4 X 1" WOODRUFF KEY
14	659-092P	2	WHEEL BACKING PLATE

MOTOR ASSEMBLY & RELATED PARTS FOR 25.5HP KAWASAKI

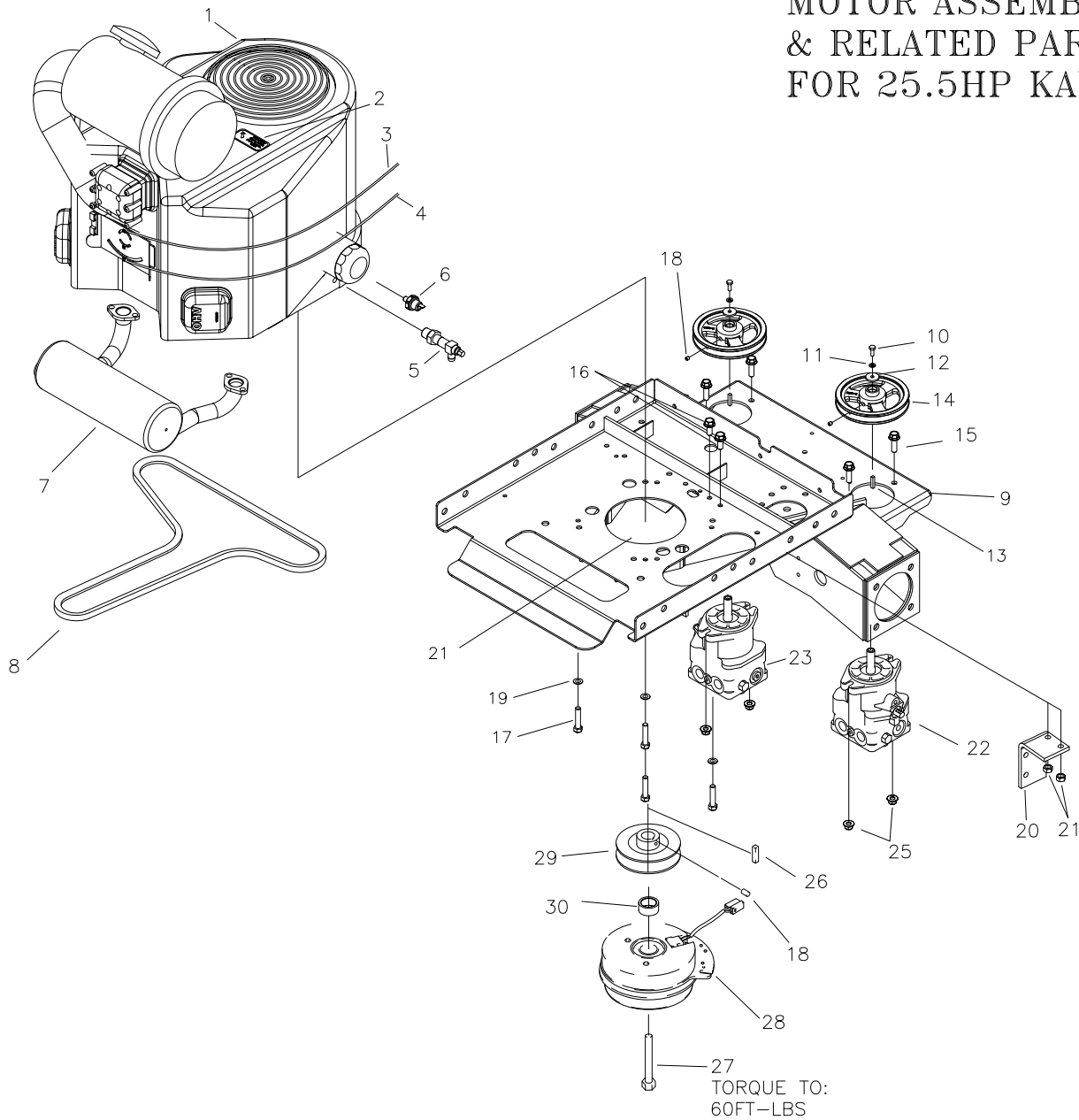

REF NO.	PART NO.	QTY.	DESCRIPTION	REF NO.	PART NO.	QTY.	DESCRIPTION
1	M-5384	1	ENGINE, KAWASAKI, 25.5HP	16	F-2120	2	FHCS, 5/16-18 X 3/4" GR5
2	P-10077	1	DECAL, "CLEAN"	17	F-2125	4	FHCS, 3/8-16x1-1/4", YZ, GR5
3	H-2287	1	CHOKE CABLE	18	F-1228	3	1/4-20 NYLOC SETSCREW
4	H-2610	1	THROTTLE CABLE	19	F-1019-03	4	3/8" LOCK WASHER
5	H-2590	1	OIL DRAIN	20	707-033P	1	CLUTCH STOP
6	E-6307	1	OIL PRESSURE SWITCH	21	F-2063	2	NUT, 5/16-18, NYLOC FLANGED
7	H-2850	1	MUFFLER	22	D-3907-01	1	PUMP, 12CC, RH
8	D-3524	1	V-BELT A-71 KEVLAR	23	D-3907-02	1	PUMP, 12CC LH
9	663-176W	1	MOTOR MOUNT	24	F-1009-03	8	3/8" FLAT WASHER
10	F-1737	2	6mm X 16mm BOLT GR. 5	25	F-2151	4	NUT, 3/8-16, NYLOC FLANGED
11	F-1738	2	6mm SPRING WASHER	26	621-113P	1	KEY, 1/4" SQ. X 1 1/4"
12	F-1736	2	WASHER, .840 X .246 X .125	27	F-2113	1	7/16-20x2-1/2" CAPSCREW, GR8
13	D-3541	2	KEY - 5mm x 20mm	28	E-6532	1	1 1/8" CLUTCH BRAKE
14	647-147P	2	HYDRO PUMP PULLEY	29	647-148P	1	MOTOR PULLEY
15	F-2125	4	FHCS, 3/8-16 X 1 1/4" GR5	30	F-2043	1	SPACER

MOTOR ASSEMBLY & RELATED PARTS FOR 26.5HP EFI KOHLER

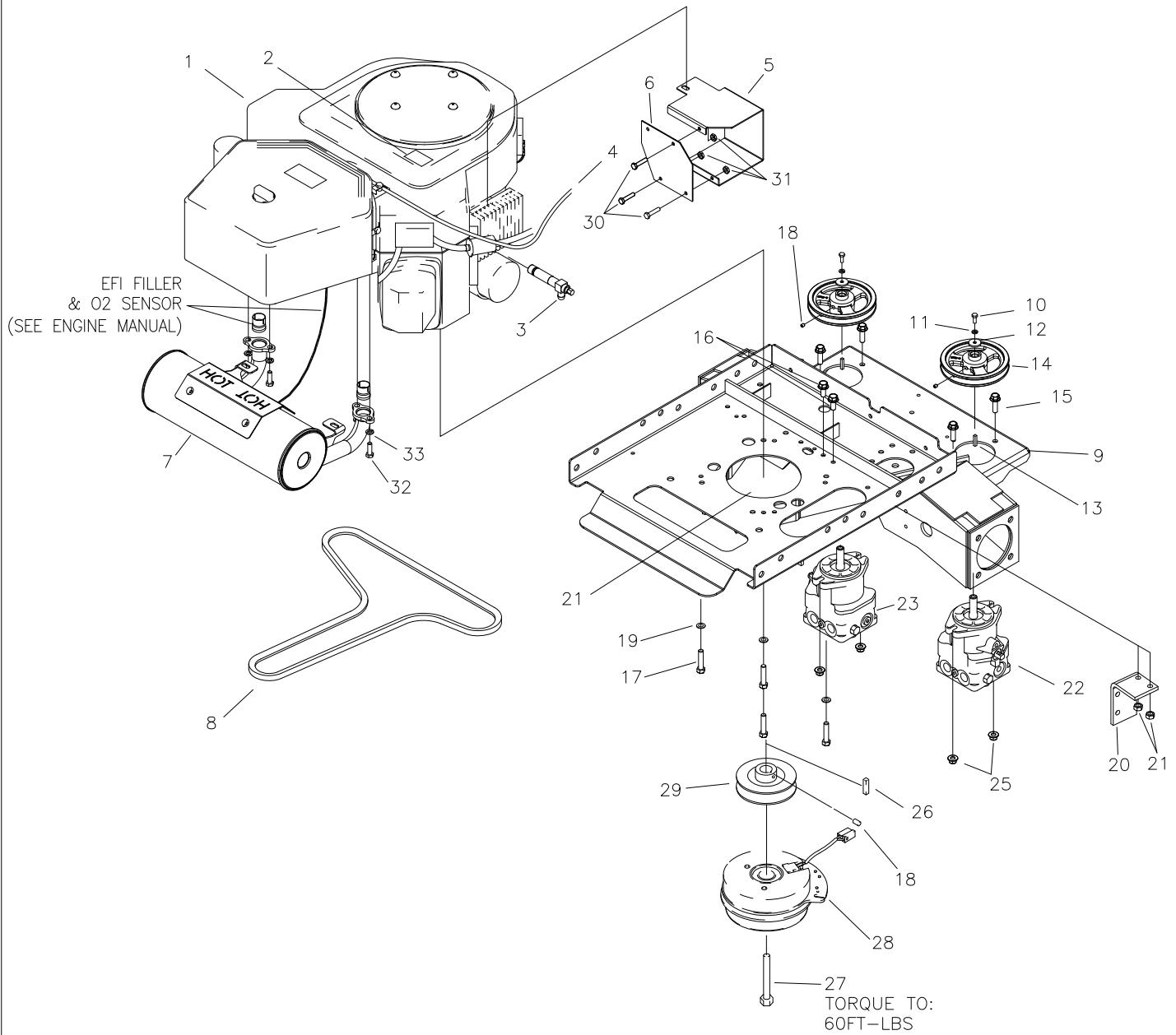

REF NO.	PART NO.	QTY.	DESCRIPTION	REF NO.	PART NO.	QTY.	DESCRIPTION
1	M-5396	1	ENGINE KOHLER, 26.5HP EFI	18	F-1228	3	1/4-20 NYLOC SETSCREW
2	P-10077	1	DECAL, "CLEAN"	19	F-1019-03	4	3/8" LOCK WASHER
3	H-2589	1	OIL DRAIN (KOHLER)	20	707-033P	1	CLUTCH STOP
4	H-2610	1	THROTTLE CABLE	21	F-2063	2	NUT, 5/16-18, NYLOC FLANGED
5	663-222P	1	PLATE, DEFLECTOR EFI	22	D-3907-01	1	PUMP, 12CC, RH
6	663-223P	1	PLATE, DEFLECTOR COVER	23	D-3907-02	1	PUMP, 12CC LH
7	H-2851	1	MUFFLER	24	F-1009-03	8	3/8" FLAT WASHER
8	D-3524	1	V-BELT A-71 KEVLAR	25	F-2151	4	NUT, 3/8-16, NYLOC FLANGED
9	663-176W	1	MOTOR MOUNT	26	621-113P	1	KEY, 1/4" SQ. X 1 1/4"
10	F-1737	2	6mm X 16mm BOLT GR. 5	27	F-2113	1	7/16-20x2-1/2" CAPSCREW, GR8
11	F-1738	2	6mm SPRING WASHER	28	E-6532	1	1 1/8" CLUTCH BRAKE
12	F-1736	2	WASHER, .840 X .246 X .125	29	647-148P	1	MOTOR PULLEY
13	D-3541	2	KEY - 5mm x 20mm	30	F-2100	3	HEX M/S (ZINC) 10-32 X 7/8
14	647-147P	2	HYDRO PUMP PULLEY	31	F-1448	3	LOCKNUT, 10-32 NYLOC YELLOW PLTD
15	F-2125	4	FHCS, 3/8-16 X 1 1/4" GR5	32	F-1015-15	4	HHCS, 5/16-18 X 1"
16	F-2120	2	FHCS, 5/16-18 X 3/4" GR5	33	F-1019-02	4	LOCK WASHER, 5/16
17	F-2040	4	FHCS, 3/8-16x1-1/2", THRD FORM				

PLUMBING KIT
HIGH PRESSURE
LINES & FITTINGS
{H-2846}

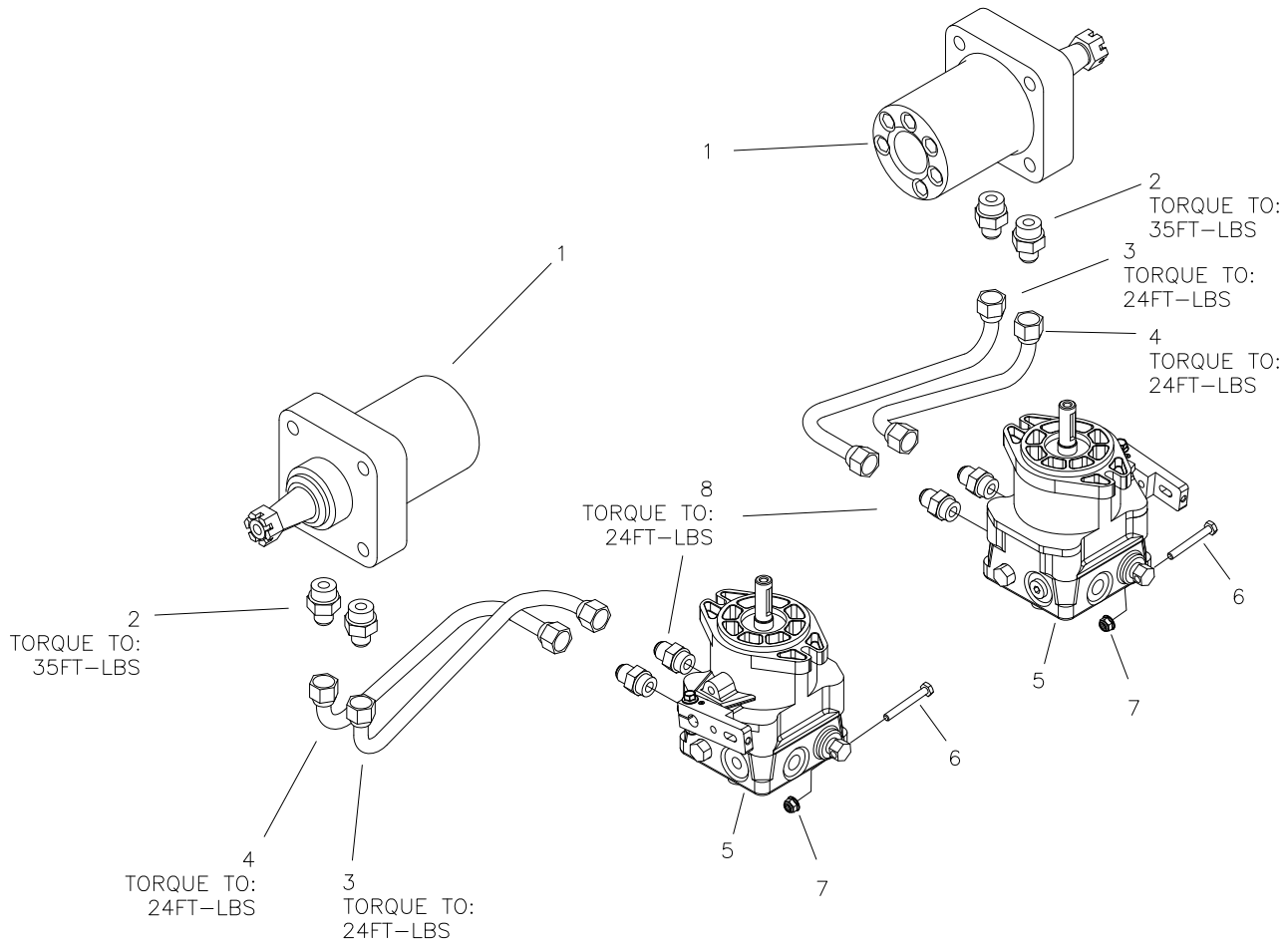

VIEWED FROM FRONT RIGHT

REF NO.	PART NO.	QTY.	DESCRIPTION
1	-----	2	SEE PAGE 22
2	H-2319	4	FITTING, STRIGHT, 7/8-14
3	H-2491	2	TUBE ASS'Y, LH. FORWARD
4	H-2492	2	TUBE ASS'Y, LH. REVERSE
5	-----	-	SEE PAGES 23 & 24
6	F-1015-09	2	1/4-20 X 2" BOLT GR. 5
7	F-2132	2	NUT, 1/4-20, NYLOC FLANGED
8	H-2436	4	FITTING, STRAIGHT, 3/4" X 1/2"

PLUMBING KIT OIL RETURN LINES & COOLER ASSEMBLY {H-2846}

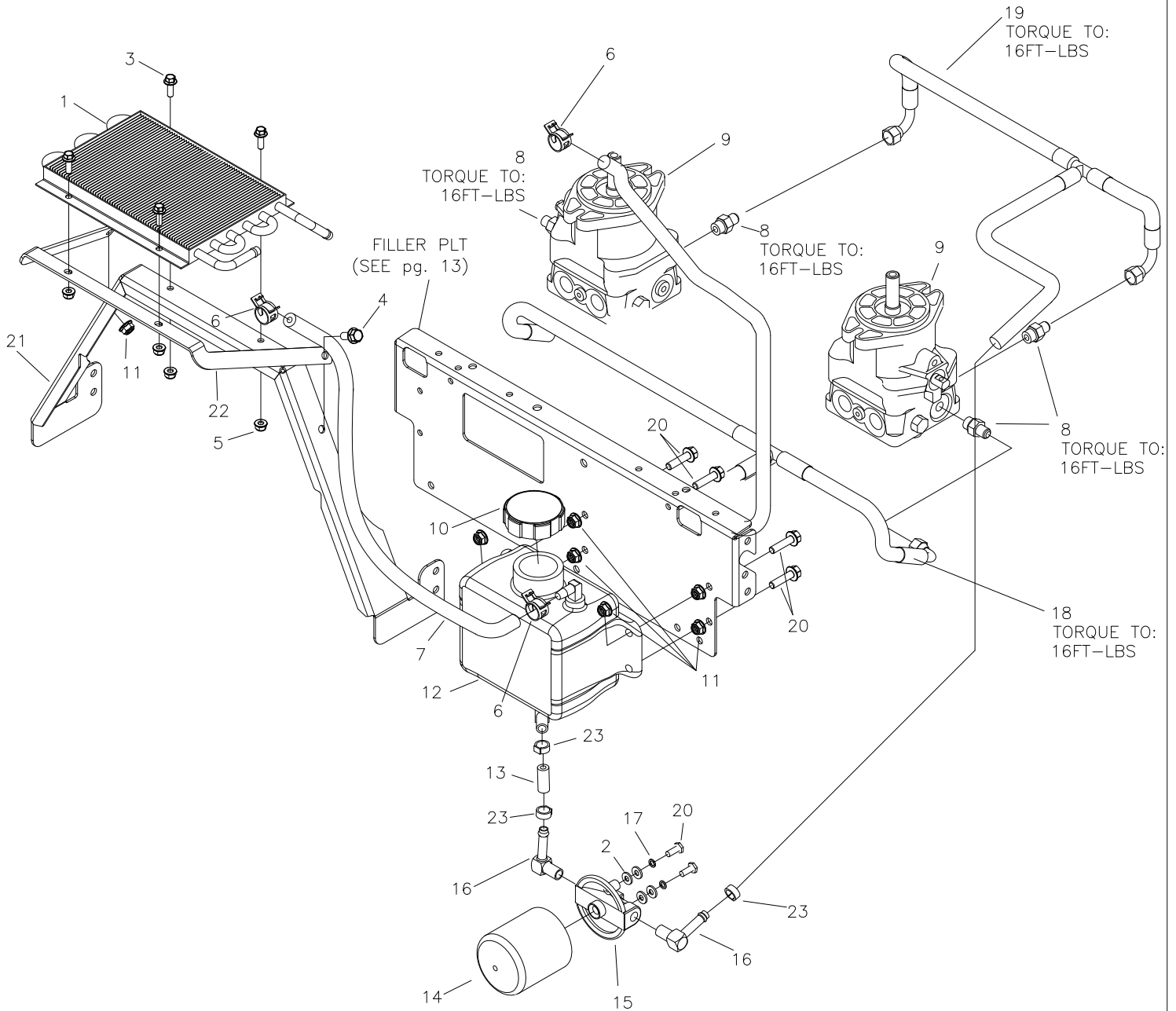

REF NO.	PART NO.	QTY.	DESCRIPTION	REF NO.	PART NO.	QTY.	DESCRIPTION
1	H-2908	1	OIL COOLER	13	H-2847	1	HOSE, 1/2"Ø X 6", HI-TEMP
2	F-1009-01	8	1/4" WASHER	14	H-2859	1	OIL FILTER
3	F-2162	6	FHCS, 1/4-20 X 3/4", YZ, GR5	15	H-2858	1	FILTER BASE
4	F-2120	2	FHCS, 5/16-18 X 3/4", YZ, GR5	16	H-2860	2	HOSE BARB 90 DEG. ELBOW
5	F-2132	4	NUT, 1/4-20, FLANGED NYLOC	17	F-1019-01	2	1/4" LOCK WASHER
6	H-3088	3	HOSE CLAMP	18	H-2849	1	RETURN HOSE TEE ASSEMBLY
7	H-2438	1	24" HOSE, 3/8" ID. HI TEMP.	19	H-2848	1	SUCTION HOSE TEE ASSEMBLY
8	H-2330	4	9/16" ADAPTER	20	F-2122	4	FHCS, 5/16-18 X 1-1/4"
9	-----	-	SEE PAGE 24	21	663-202P	1	BRACKET, COOLER
10	H-2917	1	CAP, 2.25" THREAD VENTED	22	663-203P	1	BRACE, COOLER
11	F-2063	8	NUT, 5/16-18, FLANGED NYLOC	23	H-2535	3	7/8" CLAMP
12	H-2805	1	OIL TANK				

E-6415 WIRE HARNESS & RELATED PARTS (JOYSTICK)

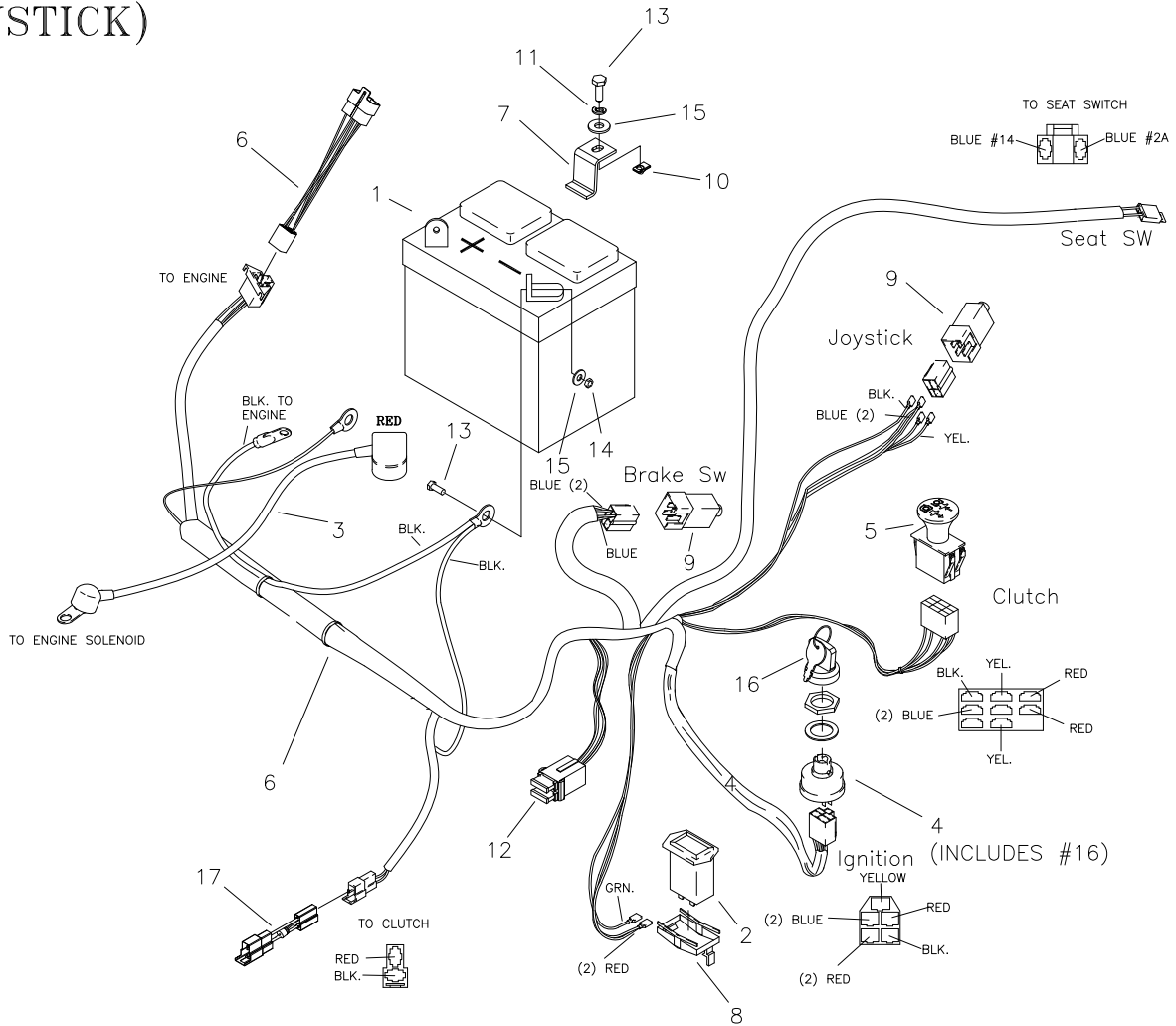

REF NO.	PART NO.	QTY.	DESCRIPTION
1	E-6271	1	BATTERY
2	E-5878	1	HOUR METER
3	E-6418	1	CABLE, BATTERY TO SOLENOID
4	E-5873	1	START SWITCH
5	E-6403	1	CLUTCH SWITCH
6	E-6417	1	WIRE HARNESS ADAPTER (KAWASAKI)
-	E-6547	1	WIRE HARNESS ADAPTER (KOHLER)
7	659-137P	1	BATTERY HOLD DOWN
8	E-6369	1	RETAINER CLIP
9	E-6297	2	BRAKE SWITCH
10	F-1858	1	1/4-20 U-NUT
11	F-1019-01	1	1/4" LOCK WASHER
12	E-6207	2	FUSE, #ATC-30
13	F-1538	3	1/4-20 X 3/4" GR. 5
14	F-1158	2	1/4-20 LOCK NUT
15	F-1009-01	5	1/4" FLAT WASHER
16	E-6445	1	KEY, SET
17	E-6461	1	CLUTCH SPIKE SUPPRESSOR (KOHLER)
*	E-6374	1	SEAT SWITCH (NOT SHOWN)

E-6416 WIRE HARNESS & RELATED PARTS (TWINSTICK)

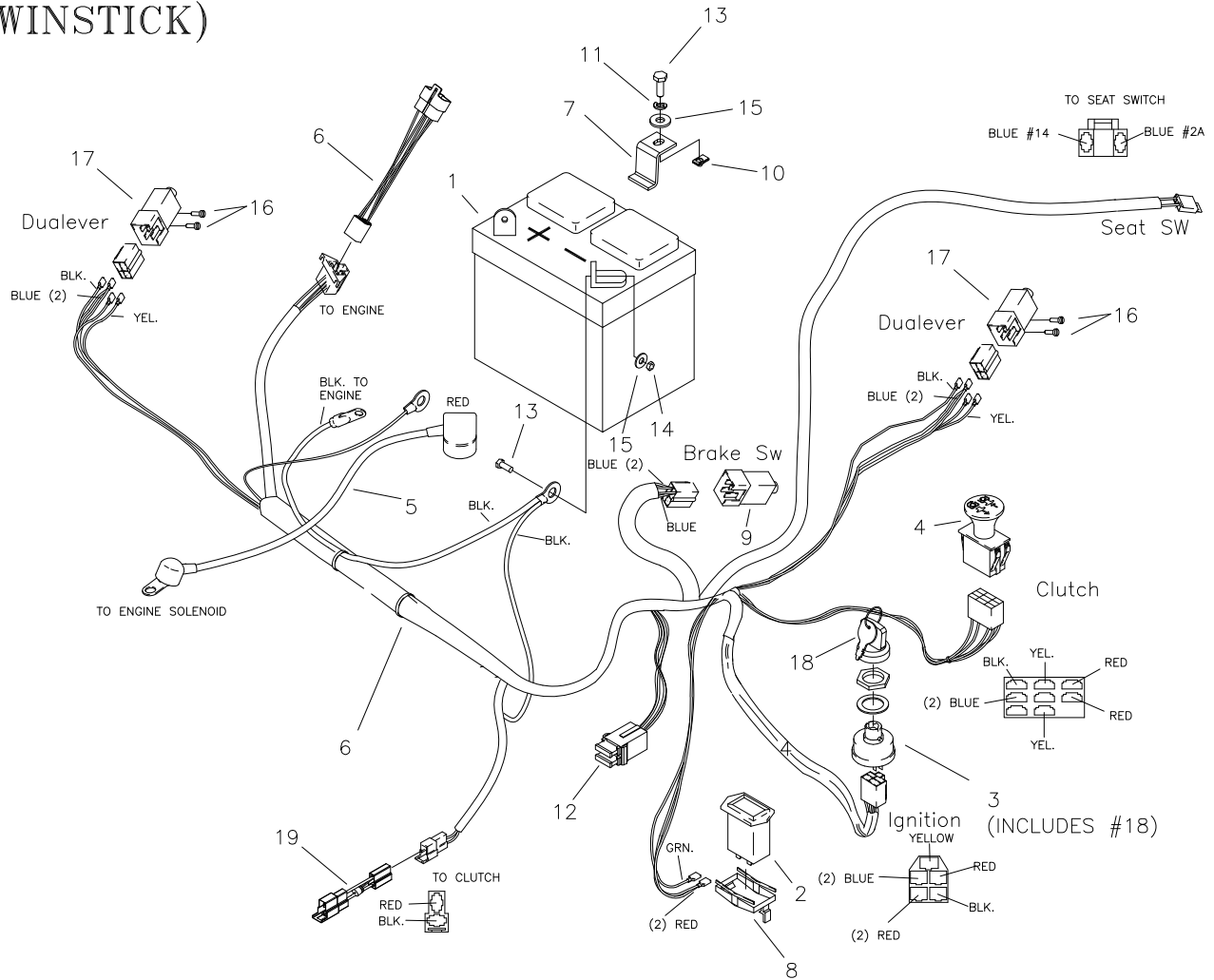

REF NO.	PART NO.	QTY.	DESCRIPTION
1	E-6271	1	BATTERY
2	E-5878	1	HOUR METER
3	E-5873	1	START SWITCH
4	E-6403	1	CLUTCH SWITCH
5	E-6418	1	CABLE, BATTERY TO SOLENOID
6	E-6417	1	WIRE HARNESS ADAPTER (KAWASAKI)
-	E-6547	1	WIRE HARNESS ADAPTER (KOHLER)
7	659-137P	1	BATTERY HOLD DOWN
8	E-6369	1	RETAINER CLIP
9	E-6297	3	BRAKE SWITCH
10	F-1858	1	1/4-20 U-NUT
11	F-1019-01	1	1/4" LOCK WASHER
12	E-6207	2	FUSE, #ATC-30
13	F-1538	3	1/4-20 X 3/4" GR. 5
14	F-1158	2	1/4-20 LOCK NUT
15	F-1009-01	5	1/4" FLAT WASHER
16	F-1994	4	#10 SCREW, 5/8" LONG
17	647-112A	2	SWITCH ARM ASSEMBLY
18	E-6445	1	KEY, SET
19	E-6461	1	CLUTCH SPIKE SUPPRESSOR (KOHLER)
*	E-6374	1	SEAT SWITCH (NOT SHOWN)

E-6417 KAWASAKI ADAPTER HARNESS & RELATED PARTS

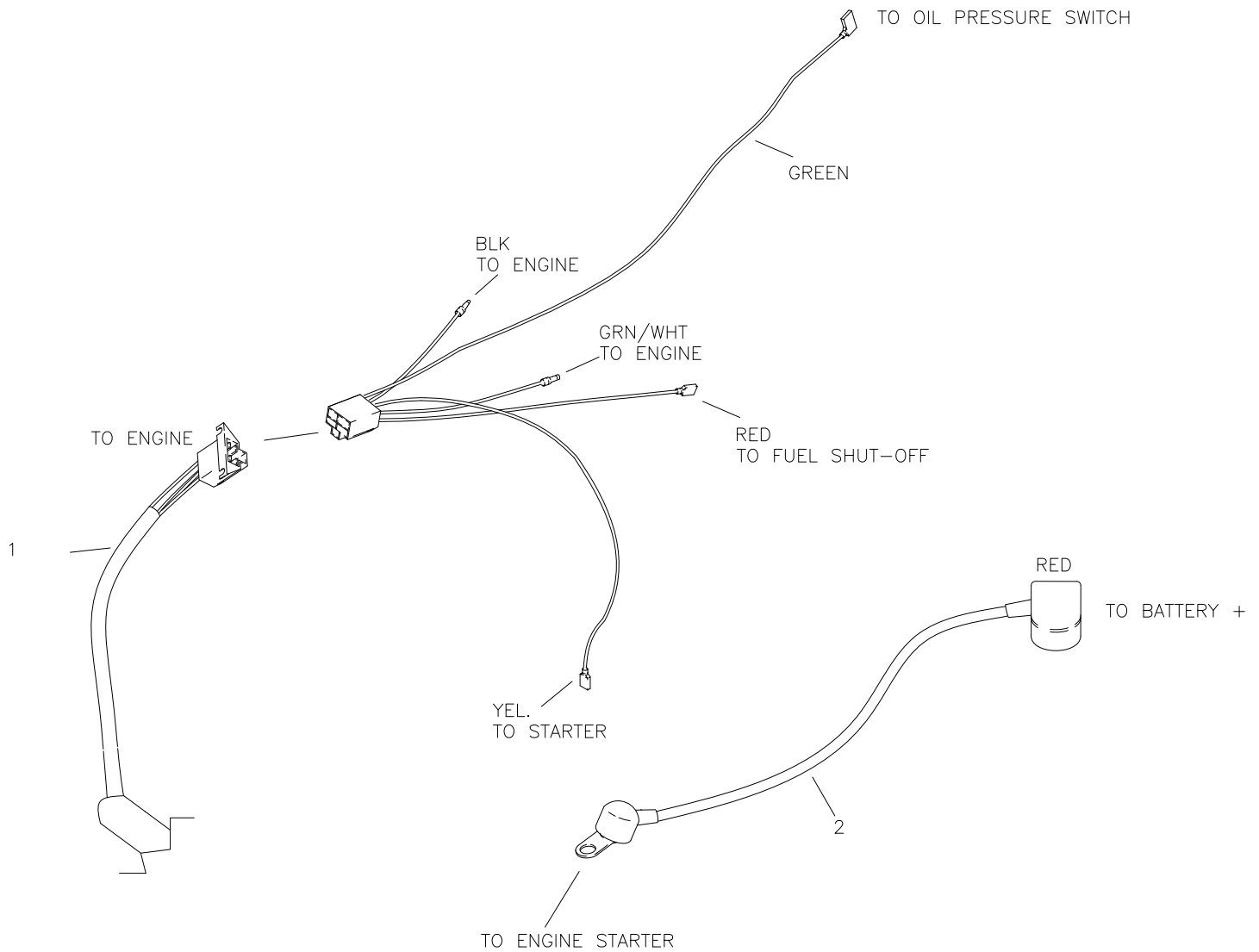

REF NO.	PART NO.	QTY.	DESCRIPTION
1	E-6415	1	WIRE HARNESS (JOYSTICK)
-	E-6416	1	WIRE HARNESS (TWINSTICK)
2	E-6418	1	CABLE, BATTERY TO SOLENOID

E-6547 KOHLER E.F.I. HARNESS ADAPTER & RELATED PARTS

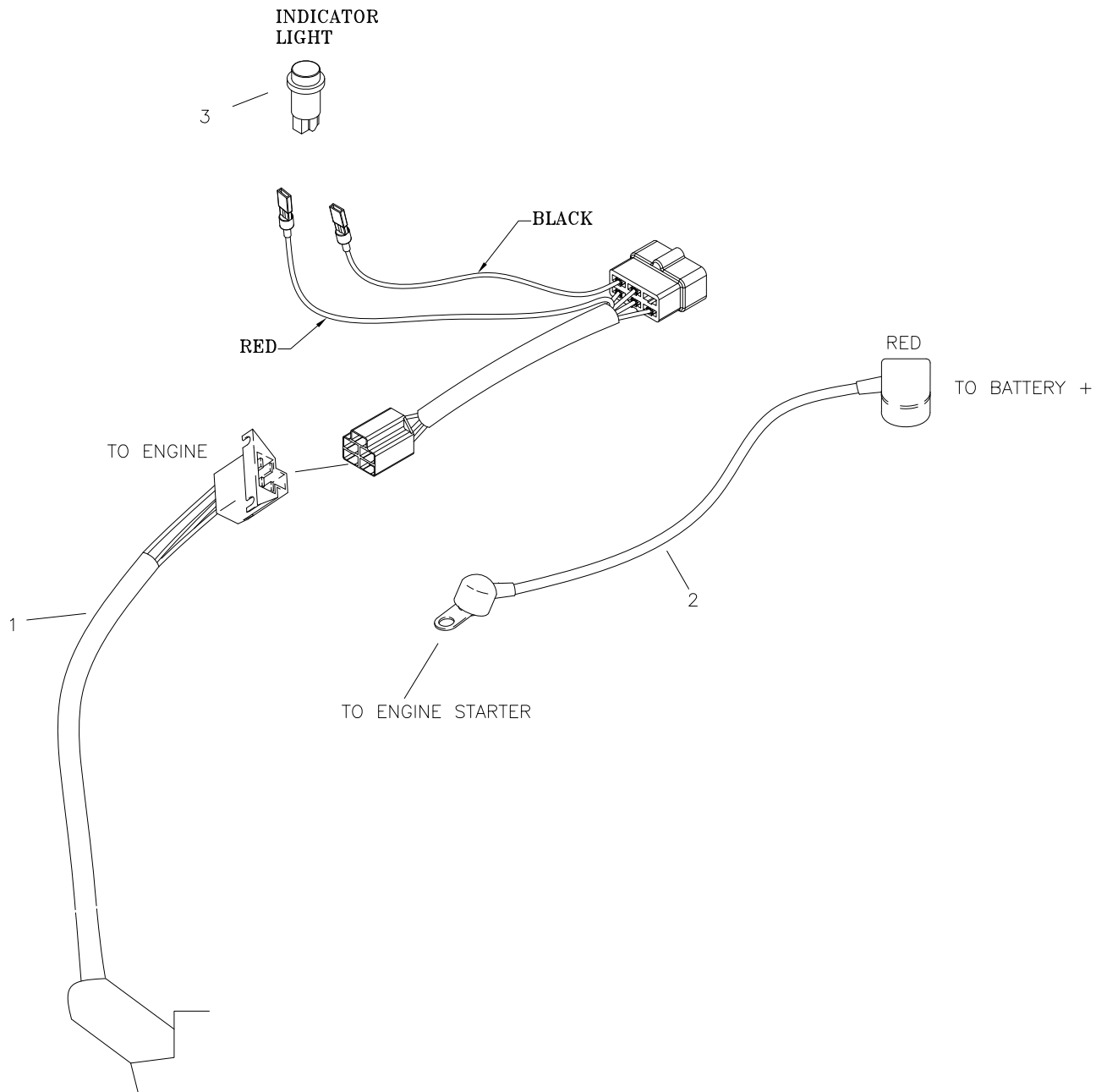

REF NO.	PART NO.	QTY.	DESCRIPTION
1	E-6415	1	WIRE HARNESS (JOYSTICK)
-	E-6416	1	WIRE HARNESS (TWINSTICK)
2	E-6418	1	CABLE, BATTERY TO SOLENOID
3	E-6314	1	INDICATOR LIGHT

Repair Parts Manual



CHARGER™

1050/1055

Country Clipper Division
Shivers Manufacturing Inc.
613 W. English St.
Corydon, IA 50060-0467
Ph. 641-872-2544
Fax. 641-872-1593