

# Safety Instructions & Operators Manual

# COUNTRY CLIPPER® ZERO TURN MOWER

**XLT** C300

**CHALLENGER** D500

Congratulations for buying a **Country Clipper** product. Your **Country Clipper** Zero Turn Radius Riding Mower was designed and built to provide long and trouble free service. Keep in mind that it, like any other mechanical device, can be potentially dangerous if used improperly, and hazard control and accident prevention are dependent upon the awareness, concern, prudence, and proper training of personnel involved in the operation, transport, maintenance, and storage of the equipment. Study this manual and pay special attention to the important Safety Precautions on pages 3-5. Following these instructions will help you continue to enjoy the trouble-free performance expected of the **Country Clipper** product.

## TABLE OF CONTENTS

<b>MODEL NUMBER'S &amp; SERIAL NUMBER'S .....</b>	<b>2</b>
<b>SAFETY.....</b>	<b>3</b>
ACCIDENT PATTERNS TO AVOID .....	3
SAFETY INSTRUCTIONS AND RECOMMENDATIONS .....	3
SAFETY INTERLOCK SYSTEM .....	4
<b>START UP AND OPERATION.....</b>	<b>5</b>
CHECKLIST BEFORE OPERATION .....	5
CONTROL LOCATIONS JOYSTICK MODELS.....	5
OPERATION JOYSTICK MODELS.....	6
CONTROL LOCATIONS TWINSTICK MODELS.....	6
OPERATION TWINSTICK MODELS.....	7
OPERATION FREE WHEEL.....	8
MOWING RECOMMENDATIONS .....	9
MOWER TRANSPORT RECOMMENDATIONS.....	9
<b>MAINTENANCE.....</b>	<b>10</b>
MAINTENANCE SCHEDULE .....	10
MAINTENANCE INSTRUCTIONS.....	11
HYDROSTATIC TRANSMISSION.....	14
PROCEDURE FOR RAISING AND LOWERING THE DECK FOR SERVICING .....	16
LEVELING THE DECK.....	17
<b>TROUBLE SHOOTING CHECK LIST.....</b>	<b>19</b>
<b>BELT ROUTINGS .....</b>	<b>20</b>
<b>NOTES / SERVICE RECORDS:.....</b>	<b>21</b>
<b>NOTES / SERVICE RECORDS:.....</b>	<b>22</b>

## MODEL NUMBER'S & SERIAL NUMBER'S

Date of Purchase: \_\_\_\_\_

Mower Model Number: \_\_\_\_\_

Mower Serial Number: \_\_\_\_\_

Engine Spec Number: \_\_\_\_\_

Hydro Serial Number (RH): \_\_\_\_\_

Hydro Serial Number (LH): \_\_\_\_\_

# SAFETY

## ACCIDENT PATTERNS TO AVOID

- I. **CONTACT WITH THE ROTATING BLADE** -- This accident usually happens when the operator is clearing the discharge chute of grass, (especially when the grass is wet), or when the operator adjusts the machine without turning it off and waiting for the blades to completely stop.
- II. **PROPELLED OBJECTS** -- Sticks, rocks, wires, and other objects can be propelled out through the discharge chute or from under the mower housing. Bystanders are particularly vulnerable.
- III. **GRASS CATCHER OR GUARD** -- The mower shall not be operated without either the entire grass catcher or guard in place.
- IV. **OVERTURNING** -- This happens when riding mowers are used on steep slopes, embankments or hills. The operator in these cases can come in contact with the blades or sustain injuries during a fall.
- V. **MOWER RUNNING OVER THE VICTIM** -- This usually happens when a riding mower is driven in reverse. The accident victims are most often young children whom, unseen by the operator of the mower, were in the area being mowed.

AT **COUNTRY CLIPPER**, WE SHARE YOUR DESIRE TO PROTECT YOURSELF, YOUR FAMILY, YOUR FRIENDS AND YOUR NEIGHBORS FROM ACCIDENTAL INJURY. OBSERVING AND ENFORCING THE FOLLOWING GUIDELINES WILL HELP TO ENSURE THE SAFETY OF EVERYONE.

## PLEASE BE CAREFUL!

### SAFETY INSTRUCTIONS AND RECOMMENDATIONS

1. **PEOPLE WHO OPERATE, SERVICE, OR ARE OTHERWISE ASSOCIATED** with the **Country Clipper** Zero Turn Radius Mower should be trained in its proper use and warned of its dangers. Before operating, adjusting, or servicing the **Country Clipper** Zero Turn Radius Mower they should read and understand this entire manual and the engine owner's manual.
2. **AVOID CONTACT WITH MOVING PARTS.** Keep hands and feet from under mower deck and away from blades at all times. Turn engine (motor) off if you must unclog the chute.
3. **AVOID HILLS AND SLOPES.** Use extreme caution when mowing up or down slopes. NEVER mow across the face of a slope. If a slope must be ascended, back up the slope; drive forward when descending. Reduce speed and use caution to start, stop and maneuver. To prevent loss of control on a slope avoid sharp turns, sudden changes in direction, and sudden stops and starts.
4. **DISENGAGE POWER TO MOWER BEFORE BACKING UP.** Do not mow in reverse unless ABSOLUTELY necessary and then only after turning around and observing the entire area behind the mower. Go slowly. Most "running over victim" accidents occur in reverse.
5. **BEGINNING OPERATORS SHOULD LEARN HOW TO STEER** the **Country Clipper** Zero Turn Radius Mower before attempting to mow. Start with slow engine speed and drive without the blades engaged in an open area until comfortable with the machine.
6. **KNOW HOW TO STOP QUICKLY.** Know the location and operation of every control, especially how to brake and how to disengage the mower blades.
7. **DO NOT MOVE THE JOYSTICK CONTROL LEVER** from forward position to reverse position or reverse position to forward position rapidly. The speed and/or direction of travel is affected instantly by movement of the Control Lever(s).
8. **DO NOT ALLOW CHILDREN TO OPERATE MOWER.** Do not allow others who have not had instruction to operate mower.
9. **ALWAYS TURN ENGINE OFF AND REMOVE KEY** before leaving the mower to prevent children and inexperienced operators from starting the engine. Never leave the mower unattended with engine running. Always wait for all moving parts and all sounds to stop before leaving operator's seat.
10. **WEAR STURDY, ROUGH-SOLED WORK SHOES AND CLOSE-FITTING SLACKS AND SHIRTS.** Never operate mower in bare feet, sandals or sneakers.
11. **KNOW THE AREA YOU ARE TO MOW.** Watch for hidden danger such as rocks, roots, sticks, holes, bumps, and drop-offs, etc. Before mowing, pick up all debris in area to be mowed. Sharp and hard objects can be propelled at a high speed and can act like shrapnel. Walk through tall grass BEFORE MOWING to make sure there are no hidden dangers. Mow higher than desired in tall grass to expose any hidden objects and/or obstacles, clean the area, and then mow to the desired height.
12. **NEVER REFUEL A MOWER INDOORS.** Allow the engine time to cool before refueling. Unseen vapors may be ignited by a spark. Always clean up spilled gasoline. Never run the engine indoors in a garage or any other closed building. Allow engine to cool before storing in any enclosure. The engine exhaust and gasoline fumes are dangerous.
13. **DISENGAGE BLADES BEFORE DRIVING ACROSS WALKS** or exposed objects.

14. **NEVER REMOVE THE FUEL CAP** or add gasoline to a running or hot engine that has not been allowed to cool for several minutes after running. Always make sure the gas cap is in place.
15. **NEVER CARRY PASSENGERS.**
16. **DO NOT SMOKE AROUND THE MOWER** or the gasoline storage container. Gasoline fumes can easily ignite.
17. **KEEP GASOLINE IN A WELL-VENTILATED AREA** away from your living quarters and in tightly-capped safety cans. Never store mower with gasoline in the tank inside a building where fumes may reach open flame or spark.
18. **DISENGAGE BLADES, STOP ENGINE AND REMOVE IGNITION KEY** before any servicing. Be sure all moving parts and all sounds have stopped. Let engine cool and disconnect the spark plugs so the engine cannot start by accident. A SLIGHT ROTATION OF THE BLADES COULD START THE ENGINE.
19. **KEEP ALL NUTS, BOLTS, AND SCREWS TIGHT** to be sure equipment is in safe working condition, especially blade mounting bolts.
20. **MOWER SHOULD BE STOPPED AND INSPECTED FOR DAMAGE** after striking a foreign object and the damage should be repaired before restarting and operating the equipment. Stop immediately and check for damage or loose parts if mower should start vibrating.
21. **KEEP SAFETY DEVICES AND GUARDS IN PLACE.** If any of the safety switches become inoperable, have them repaired immediately.
22. **DO NOT STEP OR STAND ON THE MOWER HOUSING.** Step or stand only on the foot deck.
23. **WATCH OUT FOR TRAFFIC** near roadways and when crossing roads.
24. **DO NOT USE MOWER WHEN GRASS IS WET OR SLIPPERY.**
25. **THIS MACHINE IS NOT MEANT FOR HIGHWAY OR STREET USE.** It is not a recreational vehicle and it should not be operated as such.
26. **ALWAYS DISENGAGE THE MOWER BLADE CLUTCH** when transporting.
27. **KEEP ALL SAFETY LABELS IN LEGIBLE CONDITION.** Remove grease, dirt, grass, etc. that may cover safety labels. Replace any safety label that is missing or damaged.
28. **WEAR PERSONAL PROTECTIVE EQUIPMENT.** Eye, ear, feet and head protection is recommended.
29. **ONLY USE COUNTRY CLIPPER APPROVED ACCESSORIES.**
30. **DO NOT CHANGE THE ENGINE GOVERNOR SETTING** or over speed the engine.
31. **BEWARE OF MOWER DISCHARGE DIRECTION** and do not point it at anyone.
32. **DO NOT OPERATE THE MOWER UNDER THE INFLUENCE OF ALCOHOL OR DRUGS.**
33. **USE CARE WHEN LOADING OR UNLOADING MACHINE INTO A TRAILER OR TRUCK.**
34. **USE CARE WHEN APPROACHING BLIND CORNERS,** shrubs, trees, or other objects that may obscure vision.
35. **CLEAN ALL GRASS AND DEBRIS FROM MACHINE TO PREVENT FIRES.** Remove spilled oil or gasoline.
36. **KEEP HANDS AND FEET AWAY FROM MOVING PARTS.** If possible do not make adjustments with the engine running.
37. **NEVER MOW WHEN OTHER PEOPLE OR PETS ARE IN THE AREA.**
38. **CAREFULLY RELEASE PRESSURE FROM COMPONENTS WITH STORED ENERGY.**
39. **USE CARE WHEN REPLACING BLADES.** Wrap the blade(s) or wear gloves, and use caution when servicing them. Only replace blade(s). Never straighten or weld blade(s).
40. **USE JACK STANDS TO SUPPORT COMPONENTS** when required.

### **SAFETY INTERLOCK SYSTEM**

Your *Country Clipper* Zero Turn Radius Mower is equipped with switches interlocked for your safety.

GROUND DRIVE NEUTRAL IS WHEN THE JOYSTICK CONTROL LEVER IS IN THE “DOWN” POSITION.

1. The mower blades must be disengaged and the Joystick Control Lever must be in the neutral position before the engine will start.
2. The engine will stop if the mower blade clutch is engaged when the operator leaves the driver’s seat.
3. The engine will stop if the Joystick Control Lever is not in the neutral position when the operator leaves the driver’s seat.
4. The engine will stop if the brake is “SET” and the Joystick Control Lever are not in the neutral position.
5. The engine will stop if the clutch is engaged while the operator is not in the seat.

**DO NOT OPERATE MOWER IF SAFETY SWITCHES AND GUARDS ARE NOT OPERATING PROPERLY**

## START UP AND OPERATION

### CHECKLIST BEFORE OPERATION

1. Make sure fuel tank is full. Use regular unleaded gasoline (see engine owner's manual for more details).



### **WARNING**



HANDLE GASOLINE WITH CARE -- IT IS HIGHLY FLAMMABLE. DO NOT SMOKE. ENGINE SHOULD BE OFF AND COOL. USE APPROVED GAS CONTAINER. NEVER FILL TANK INDOORS. WIPE UP ANY SPILLS. REPLACE CAP TIGHTLY.

2. Make sure dirt and foreign matter is kept out of gas tank. Use a clean funnel and gas can.
3. Do not mix oil with gasoline.
4. Do not use white, high test or premium gasoline. Do not use deicers, carburetor cleaners, or other such additives (Use fuel recommended by Engine Manufacturer)
5. Check the crankcase oil level. Make sure the engine is off. The mower should be parked on a level area. Do not overfill. (See your engine manual for more detailed instruction.)
6. Inspect V-belts.
7. Check tire pressure.
8. Make sure underside of mower deck is free of grass.
9. Make sure mower blades are sharp and secured tightly.
10. Clean the air intake screen on the engine if necessary.
11. Perform any other maintenance as it becomes necessary. (See the "Maintenance" section of this manual.)

### **IMPORTANT:**

Before cutting grass, clutch must be broken-in as follows: With engine at full RPM engage deck until blades come to full speed and then disengage until blades come to a complete stop. Repeat 10 times to "break-in" the clutch properly.

### CONTROL LOCATIONS JOYSTICK MODELS

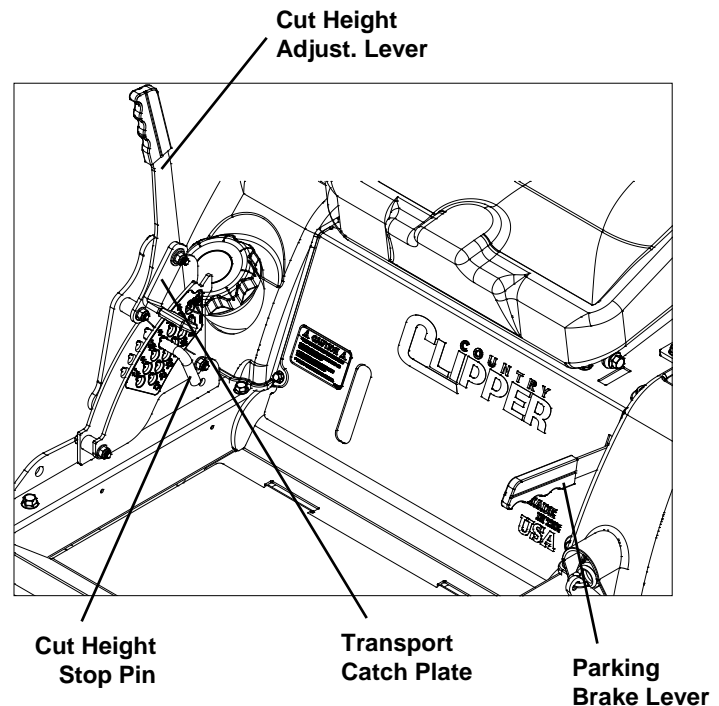
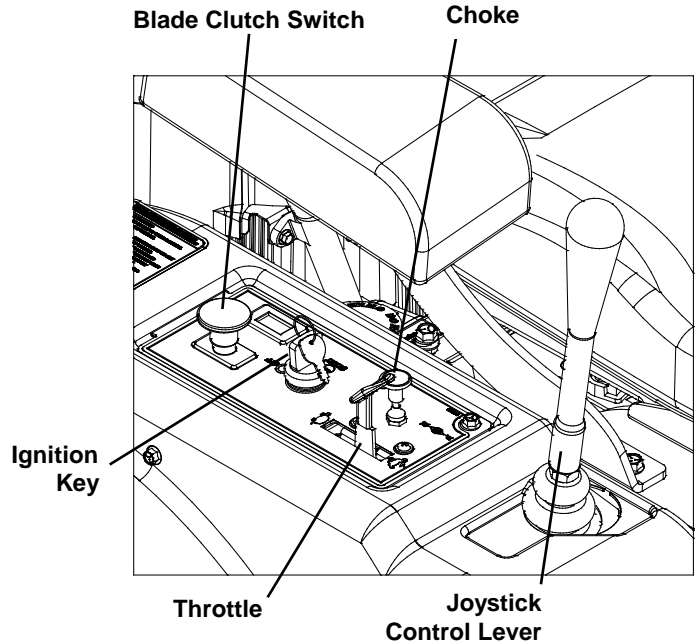

### **WARNING**



AVOID INHALING EXHAUST FUMES! CARBON MONOXIDE GAS IS COLORLESS, ODORLESS AND CAN CAUSE UNCONSCIOUSNESS AND IS POTENTIALLY LETHAL. DO NOT RUN LAWN MOWER IN GARAGE OR OTHER CONFINED AREAS.

## **OPERATION**

### **JOYSTICK MODELS**

1. **MOVE JOYSTICK CONTROL LEVER** to neutral “DOWN” position.
2. **SET PARKING BRAKE.** Pull up to set.
3. **DISENGAGE MOWER BLADE CLUTCH** by moving clutch switch to “OFF” position.
4. **PULL ENGINE CHOKE CONTROL** to full position for cold starts.
5. **SET ENGINE THROTTLE TO 1/2 THROTTLE.**
6. **TURN IGNITION KEY** to “START” position and release to “RUN” as soon as engine starts. **NOTE:** Prolonged cranking will damage starter motor and shorten the battery life
7. **ADJUST ENGINE THROTTLE** for desired engine smoothness and speed. However, use full throttle while mowing.
8. **RELEASE PARKING BRAKE.** Push brake lever down to release.

#### **IMPORTANT:**

Until the operator is familiar with the *Country Clipper* Zero Turn Radius Mower, he/she should follow these recommendations: **1)** Disengage the mower blades. **2)** Go very slowly until thoroughly familiar with the machine. **3)** Keep away from fences, buildings, and other obstructions. **4)** Move the Joystick Control Lever smoothly and slowly. **5)** Practice until operation is smooth and efficient.

#### **9. TO DRIVE:**

- A. Move the Joystick Control Lever to the “UP” position.
- B. Move the Joystick Control Lever forward to move forward. Increasing forward movement of the Joystick Control Lever will increase the speed of travel.
- C. To reverse the direction, pull the Joystick Control Lever slightly back.
- D. To turn, move the Joystick Control Lever toward the direction you want to turn.
- E. To turn on a zero radius axis, go slowly and move the Joystick Control Lever to the side you wish to turn and slightly to the rear at the same time.

**11. CUTTING HEIGHT ADJUSTMENT:** While holding the Cut Height Adjust Lever with enough hand pressure to freely move the Cut Height Pin, rotate the Cut Height Stop Pin so the key on the pin aligns with the key slot, then pull it out and move the lever to the desired cut height. Reinsert the Cut Height Stop Pin.

**12. ENGAGE MOWER BLADE CLUTCH:** Set engine throttle to 1/2–3/4 throttle, engage the Blade Clutch Switch to the “ON” position, set throttle to full.

**Note:** The engine will not start with the blade clutch switch in the “ON” position. Engine will stop if the clutch switch is “ON” and the Operator is not in the seat.



### **CAUTION**



**AVOID HILLS AND SLOPES. USE EXTREME CAUTION WHEN MOWING UP OR DOWN SLOPES. NEVER MOW ACROSS THE FACE OF A SLOPE. IF A SLOPE MUST BE ASCENDED, BACK UP THE SLOPE; DRIVE FORWARD WHEN DESCENDING.**

#### **13. TO STOP:**

- A. Move Joystick Control Lever to neutral position and then to the “DOWN” position.
- B. Disengage the mower blade clutch by moving the clutch to the “OFF” position.
- C. Set the parking brake.
- D. Turn ignition key to “OFF” position.
- E. Remove the key and wait for all movement and sound to cease before dismounting.



### **CAUTION**



**WHEN LEAVING THE MOWER UNATTENDED, ALWAYS REMOVE THE KEY AND SET THE PARKING BRAKE, EVEN IF JUST FOR A FEW MOMENTS. HELP PROTECT CHILDREN AND OTHER UNAUTHORIZED PERSONS FROM ACCIDENTS.**



### **CAUTION**



**FOR SMOOTH, SAFE OPERATION, MOVE THE JOYSTICK CONTROL LEVER IN A GENTLE, SLOW MOTION. NEVER PULL OR PUSH THE JOYSTICK CONTROL LEVER RAPIDLY, ESPECIALLY ON GRADES.**

**10. BRAKING:** To brake mower, gently move the Joystick Control Lever in the direction opposite to travel. **Note:** If the parking brake is engaged with the Joystick Control Lever in the “UP” position the engine will stop.

## CONTROL LOCATIONS TWINSTICK MODELS

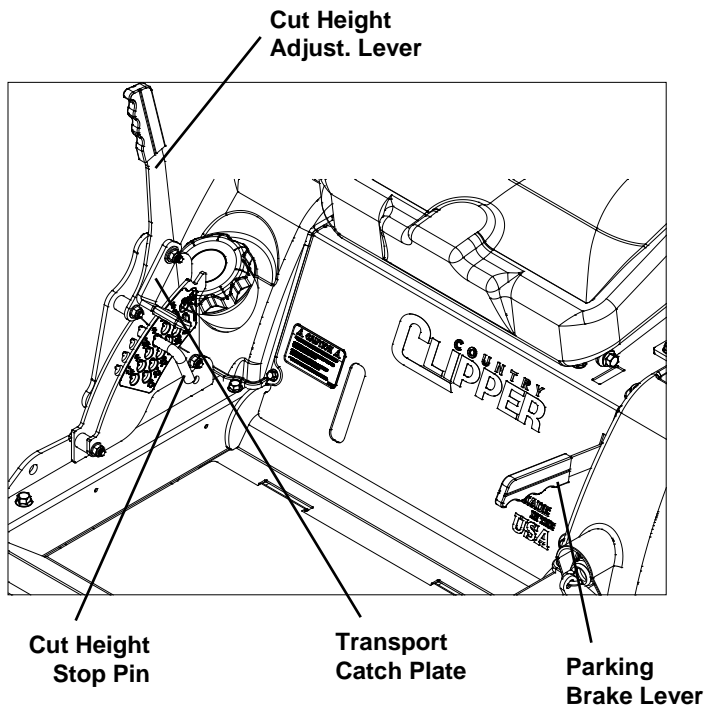
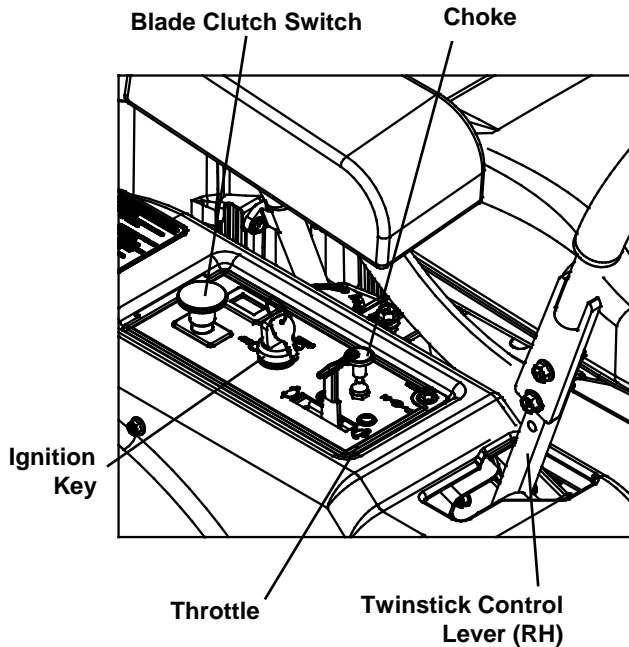

## OPERATION TWINSTICK MODELS

1. **MOVE STEERING CONTROL LEVERS** to neutral "OUT" position.
2. **SET PARKING BRAKE.** Pull up to set.
3. **DISENGAGE MOWER BLADE CLUTCH** by moving clutch switch to "OFF" position.
4. **PULL ENGINE CHOKE CONTROL** to full position for cold starts.
5. **SET ENGINE THROTTLE TO 1/2 THROTTLE.**
6. **TURN IGNITION KEY** to "START" position and release to "RUN" as soon as engine starts. NOTE: Prolonged cranking will damage starter motor and shorten the battery life.
7. **ADJUST ENGINE THROTTLE** for desired engine smoothness and speed. However, use full throttle while mowing.
8. **RELEASE PARKING BRAKE.** Push brake lever down to release.

### IMPORTANT:

Until the operator is familiar with the *Country Clipper* Zero Turn Radius Mower, he/she should follow these recommendations: **1)** Disengage the mower blades. **2)** Go very slowly until thoroughly familiar with the machine. **3)** Keep away from fences, buildings, and other obstructions. **4)** Move the Steering Control Levers smoothly and slowly. **5)** Practice until operation is smooth and efficient.

### 9. TO DRIVE:

- A. Move the Steering Control Levers to the "IN" position.
- B. Move the Steering Control Levers forward to move forward. Increasing forward movement of the Steering Control Levers will increase the speed of travel.
- C. To reverse the direction, pull the Steering Control Levers slightly back.
- D. To turn, move one Steering Control Lever slightly ahead of the other.
- E. To turn on a zero radius axis, go slowly and move one Steering Control Lever forward and one Steering Control Lever rearward. (For a right hand turn the left hand Steering Control Lever will be ahead of the right hand Steering Control. For a left hand turn the right hand Steering control will be ahead of the left hand Steering Control.)



### **WARNING**



**AVOID INHALING EXHAUST FUMES -- CARBON MONOXIDE GAS IS COLORLESS AND ODORLESS, AND CAN CAUSE UNCONSCIOUSNESS, AND IS POTENTIALLY LETHAL. DO NOT RUN LAWN MOWER IN GARAGE OR OTHER CONFINED AREA.**



### **CAUTION**



**FOR SMOOTH, SAFE OPERATION, MOVE THE STEERING CONTROL LEVER(S) IN A GENTLE, SLOW MOTION. NEVER PULL OR PUSH THE STEERING CONTROL LEVER(S) RAPIDLY, ESPECIALLY ON GRADES.**



**10. BRAKING:** To brake mower, gently move the Steering Control Levers in the direction opposite to travel. NOTE: If the parking brake is engaged with the Steering Control Lever(s) in the "IN" position the engine will stop.

**11. CUTTING HEIGHT ADJUSTMENT:** While holding the Cut Height Adjustment Lever with enough hand pressure to freely move the Cut Height Pin, rotate the Cut Height Stop Pin so the key on the pin aligns with the key slot, then pull it out and move the Cut Height Adjustment Lever to the desired cut height. Reinsert the Cut Height Stop Pin.

**12. ENGAGE MOWER BLADE CLUTCH:** Set engine throttle to 1/2–3/4 throttle, engage the Blade Clutch Switch to the "ON" position, set throttle to full.

Note: The engine will not start with the blade clutch switch in the "ON" position. Engine will stop if the clutch switch is "ON" and the Operator is not in the seat.



## **CAUTION**



**AVOID HILLS AND SLOPES. USE EXTREME CAUTION WHEN MOWING UP OR DOWN SLOPES. NEVER MOW ACROSS THE FACE OF A SLOPE. IF A SLOPE MUST BE ASCENDED, BACK UP THE SLOPE; DRIVE FORWARD WHEN DESCENDING.**

### **13. TO STOP:**

- A. Move Steering Control Levers to neutral position and then to the "OUT" position.
- B. Disengage the mower blade clutch by moving the clutch to the "OFF" position.
- C. Set the parking brake.
- D. Turn ignition key to "OFF" position.
- E. Remove the key and wait for all movement and sounds to cease before dismounting.



## **CAUTION**



**WHEN LEAVING THE MOWER UNATTENDED, ALWAYS REMOVE THE KEY AND SET THE PARKING BRAKE, EVEN IF JUST FOR A FEW MOMENTS. HELP PROTECT CHILDREN AND OTHER UNAUTHORIZED PERSONS FROM ACCIDENTS.**

## **OPERATION** **FREE WHEEL**

### **1. TO FREE WHEEL:**

- A. Unlocking the transmissions: Pull each Transmission Release Tab rearward and move it in, away from the tire, to "hook" it in the pulled out position. Both sides must be unlocked. This will allow the mower to be rolled around a shop or towed at slow speeds (less than 2 mph) for a short distance without damaging the transmissions.
- B. To re-engage the transmissions unhook both Transmission Release Tabs from the pulled-out position.
- C. The Transmission Release Tabs are located just under the main frame inside each tire toward the back of the mower.

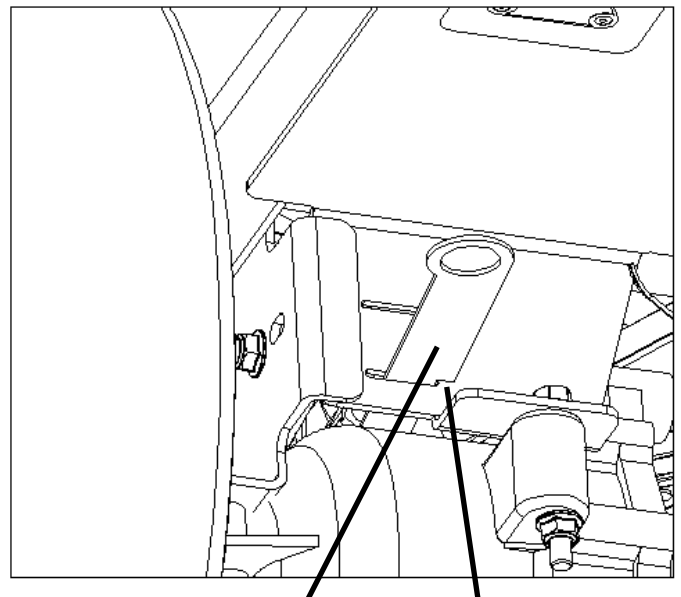

Transmission Release Tab

"Hooked" in Pulled out position

**NOTE:** The tractor should never be pulled at more than 2 miles per hour or for any appreciable distance.



## **CAUTION**



**NEVER OPERATE MOWER WITHOUT DISCHARGE CHUTE IN PLACE.**

## MOWING RECOMMENDATIONS

1. Keep mower blades sharp.
2. Make sure deck and discharge are clean.



### **CAUTION**



**TURN ENGINE OFF AND WAIT FOR ALL MOVING PARTS TO STOP BEFORE CLEANING DISCHARGE CHUTE.**

3. **When mowing tall grass**, make two passes. Mow off ½ of the desired cut on the first pass, and then the desired height the second pass. Check for hidden dangers.
4. **Go slowly for trimming.**
5. **Always cut grass with the engine at full throttle speed.**

**NOTE:** Operating the engine at full throttle assures that the cutting blades are operating at optimum cutting speed. Control ground speed with the Control Lever(s).

6. **Vary ground speed to suit conditions** (i.e. go slower in tall thick grass, on hills, wet conditions, etc.).

## MOWER TRANSPORT RECOMMENDATIONS

1. SECURING THE DECK FOR TRANSPORT:
  - A. Place the deck in the highest cut setting. It is recommended that the Cut Height Lever be allowed to rest against the Cut Height Stop Pin.

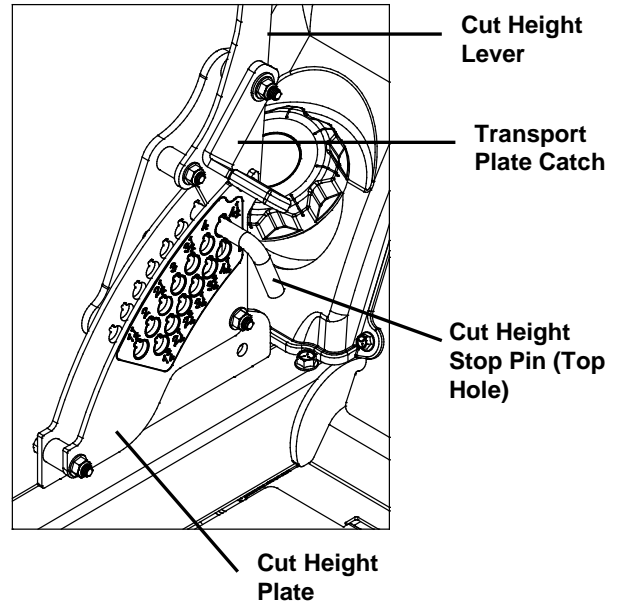

2. ENGAGE PARKING BRAKE:
3. SECURE MOWER:
  - A. It is recommended that you tie off the rear and the front of the mower to Transport Vehicle.

## MAINTENANCE



### CAUTION



**BEFORE PERFORMING ANY MAINTENANCE, TURN OFF ENGINE  
REMOVE KEY AND DISCONNECT SPARK PLUGS. USE EXTREME CARE WHEN WORKING ON MACHINERY.  
DO NOT WEAR WATCHES OR JEWELRY. DO NOT WEAR LOOSE FITTING CLOTHES, AND OBSERVE ALL  
COMMON SAFETY PRACTICES WITH TOOLS.**

### MAINTENANCE SCHEDULE

Maintenance Service Interval	Maintenance Procedure
Before Each Use or Daily	<input type="checkbox"/> Check Engine Oil Level. <input type="checkbox"/> Check Mower Blades. <input type="checkbox"/> Check Operator Presence Control System. <input type="checkbox"/> Check for Loose Hardware. <input type="checkbox"/> Clean Engine Cooling System. <input type="checkbox"/> Remove Debris From Engine. <input type="checkbox"/> Remove Debris Build-Up Hydrostatic Transmission
After Each Use or Daily	<input type="checkbox"/> Clean Grass Build-Up from Deck Cutting Chamber.
After First 5 Hours	<input type="checkbox"/> Change Engine Oil. <input type="checkbox"/> Check Wheel Lug Nuts. (75 ft/lbs or 102 Nm)
After First 75 Hours	<input type="checkbox"/> Change Hydrostatic Transmission Oil & Filter (see pg. 17-18)
Every 10 Hours	<input type="checkbox"/> Check Tire Pressure. (12-15 Psi / 83-103 kPa) <input type="checkbox"/> Check Battery Fluid <input type="checkbox"/> Sharpen Mower Blades
Every 25 Hours	<input type="checkbox"/> Service Air Cleaner. (Increase Frequency Under Severe Conditions. See Engine Owner's Manual for additional information.) <input type="checkbox"/> Check Wheel Lug Nuts. (75 ft/lbs or 102 Nm)
Every 50 Hours	<input type="checkbox"/> Check Hydraulic Oil Level. <input type="checkbox"/> Check Drive Belt Condition. <input type="checkbox"/> Check Engine RPM (3300-3500 rpm)
Every 100 Hours	<input type="checkbox"/> Change Engine Oil & Filter. (Increase Frequency Under Severe Conditions. See Engine Owner's Manual for Additional Information.) <input type="checkbox"/> Remove Engine Shrouds & Clean Cooling Fins. <input type="checkbox"/> Check Spark Plug <input type="checkbox"/> Grease Front Caster Wheel Bearings
Every 400 Hours	<input type="checkbox"/> Change Hydrostatic Transmission Oil & Filter (see pg. 17-18)
Every 500 Hours Or Annually	<input type="checkbox"/> Replace Air Filter Element <input type="checkbox"/> Check Spark Plugs <input type="checkbox"/> Service Battery

**Replace Safety decals when illegible. Write factory for free replacement.**

## MAINTENANCE INSTRUCTIONS

### 1. ENGINE:

For complete maintenance and operating information for your engine, please refer to your engine operating and maintenance instructions furnished by the engine manufacturer and included in your **Country Clipper** Zero Turn Radius Mower information packet.

NOTE: Air intake screen must be kept clean. If plugged, engine may be seriously damaged by overheating.

### 2. BATTERY:

**CAUTION**  
BATTERY ELECTROLYTE IS A POISONOUS AND CORROSIVE SULFURIC ACID SOLUTION. AVOID SPILLING ON SKIN, EYES, AND CLOTHING.

Keep the electrolyte level above the plates in each cell by adding distilled water as it becomes necessary. Add water just before operating the mower to mix the water with the solution. Be careful not to overfill the battery -- the electrolyte solution is corrosive and can cause damage to surrounding metal parts if it should spill. When taking the battery out of the mower for servicing, make sure to connect the cables to the battery exactly as they were prior to removal. Always disconnect the ground ( - ) wire **first** and always reconnect the ground ( - ) wire **last**.

Keep the battery clean. Remove the corrosion around the battery terminals by applying a solution of one part baking soda to four parts water. Coat all exposed terminal surfaces with a light layer of grease or petroleum jelly to prevent corrosion.

**NOTE:** At temperatures below 32 degrees F (0 degrees C) the full charge state must be maintained to prevent cell electrolyte from freezing and causing permanent battery damage.

### 3. TIRES:

Correct tire pressure is essential for efficient operation of the mower. Check tire pressure as requested in the maintenance schedule. Inflate tires to the pressures listed below:

Model	Front tires	Rear tires
All Models	12-15 psi 83-103 kPa	12-15 psi 83-103 kPa

Lug nuts should be torqued to 75 ft/lbs and checked regularly for tightness.

### 4. MOWER BLADES:

Check sharpness of mower blades after every 10 hours of operation. To sharpen blades proceed as follows:

**CAUTION**  
STOP ENGINE, REMOVE IGNITION KEY AND SPARK PLUGS FOR SAFETY.

- Remove bolt and blade washer mounting blade on shaft. Remove blade.
- Blades should be discarded when worn excessively.

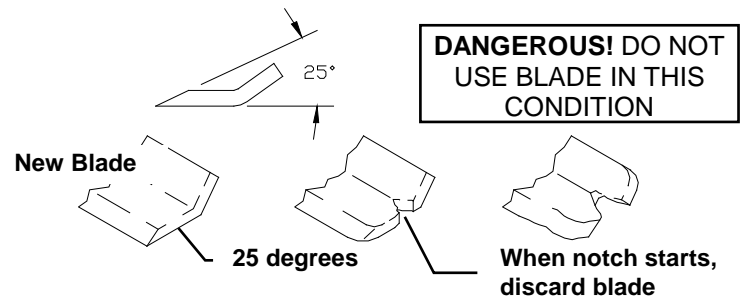

- Sharpen blades with a hand file, electric grinder or blade sharpener. Wear gloves and eye protection when sharpening. Grind blade at original 25 degree bevel.
- Check balance of blade by positioning the blade on a nail or blade balance pedestal. Grind the blade on the end that is heavier until both sides balance.
- Install blade, blade washer and bolt. Make sure to torque bolt to 100 ft-lbs.

### 5. V-BELTS:

All belts should be checked every 50 hours. Replace any belts found to be in poor condition. All belts are equipped with spring loaded belt tighteners and do not require tightening adjustments.

### 6. LUBRICATION:

- Engine: Follow engine manufacturer's recommendation.
- Front Casters: Lubricate front caster wheel bearings with several pumps of multi-purpose grease from a grease gun periodically. (See Maintenance Schedule)

**7. PARKING BRAKE ADJUSTMENT:**

- A. Move Parking Brake Lever to the "OFF" position.
- B. Adjust the top Adjustment Nut down or up so that the Brake Rod Arm is fully extended downward.
- C. Move Parking Brake Lever to the "ON" position.
- D. Adjust the Bottom Adjustment Nut so that the compression spring is compressed to 1/2".
- E. Repeat for the other side.

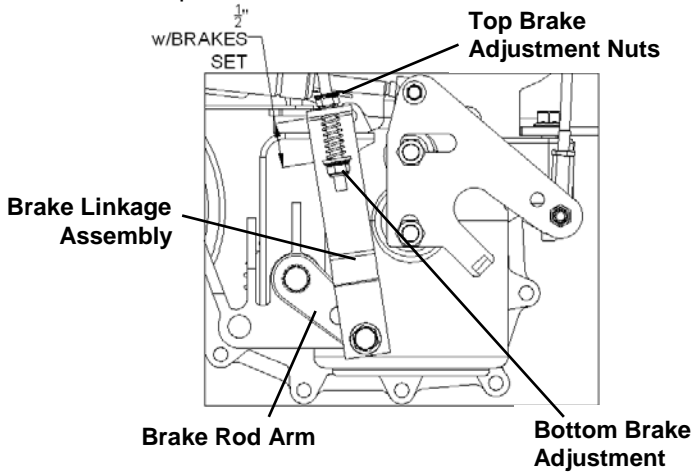

**JOYSTICK ADJUSTMENT**

**1. SETTING TRACKING AND FORWARD SPEED:**

- A. The initial setting is done with the engine TURNED OFF.
- B. The Joystick assembly contains two sets of ball joint linkages. The upper linkages that are connected to the Joystick are factory set and do not change. The lower linkages that attach to the transmission control arms will be adjusted to set the full speed and tracking. First loosen the jam nuts on both ends of the coupling nut and back the jam nut away from the coupling nut. Note: one of the jam nuts has left hand thread.
- C. Next lengthen both lower linkages by turning the coupling nut several turns to make sure that the transmission cannot bottom out in the adjustment slot when the Joystick is in the full speed forward position

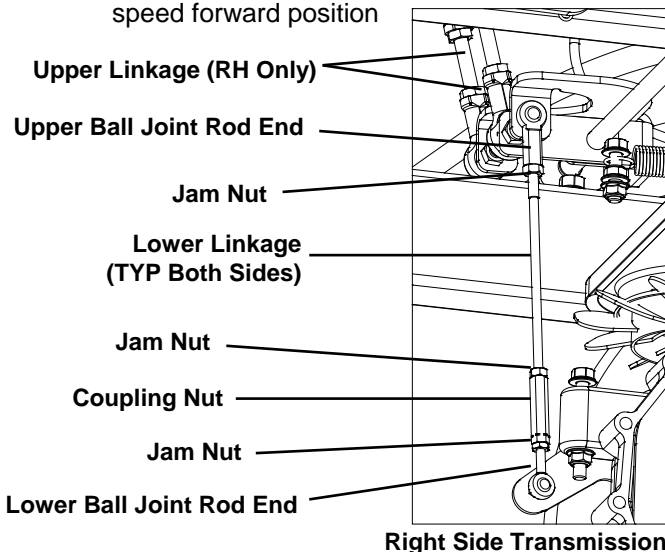

- D. While holding the Joystick Control Lever firmly in the full speed forward position shorten the linkage to the right side transmission by rotating the coupling nut until the transmission control plate just contacts the end of the slot, then lengthen the linkage by exactly one full turn. (See illustration. This may require the help of a second person)

**IMPORTANT:**  
Use two wrenches (one on the nut and one on the coupling nut or rod end housing) when loosening or tightening jam nuts to prevent damaging the rod end ball joints!

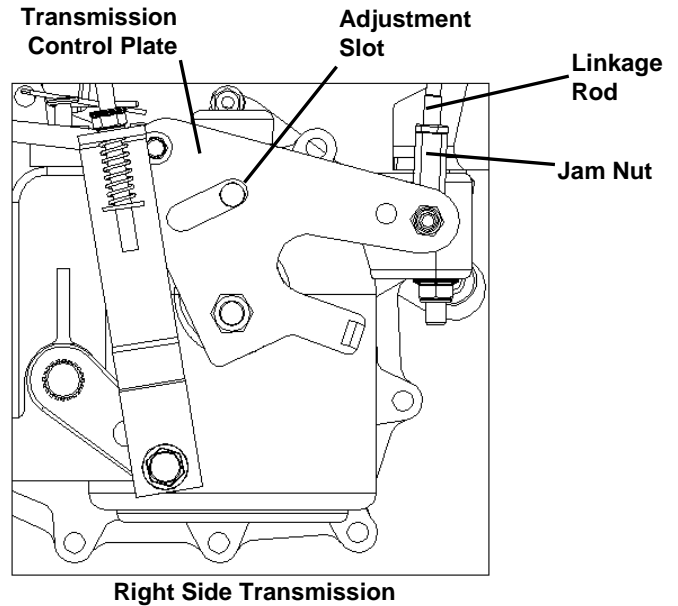

- E. The jam nuts on the right side lower linkage may now be tightened. Make sure the rod ends remain square with the plates they are mounted to and do not bind.
- F. Next hold the Joystick control lever firmly in the full speed forward position and shorten the linkage to the left side transmission by rotating the Coupling Nut until the transmission control plate just contacts the end of the slot, then lengthen the linkage by exactly one full turn. (Again, this may require the help of a second person).
- G. The jam nuts on the left side lower linkage may now be tightened. Make sure the rod ends remain square with the plates they are mounted to and do not bind.
- H. To verify that forward tracking of the transmissions is straight at full speed drive the unit in a large open area free from close obstacles. Since the adjustments made to forward speed may have caused the neutral setting to change be alert to possible movement immediately upon starting the mower for this test. If tracking adjustments are needed lengthen the linkage rod on the faster transmission using small adjustments of about 1/4 turn.

## 2. SETTING NEUTRAL:

If, with the Joystick Control Lever in the DOWN ("Neutral") or start position and the engine running the mower moves or travels, it is necessary to adjust neutral. Raise the drive wheels off the ground, secure the mower on blocks or jack stands and proceed as follows:

- A. Loosen the two nuts on the bottom of the Joystick Neutral Plate just enough so that the plate can move freely.

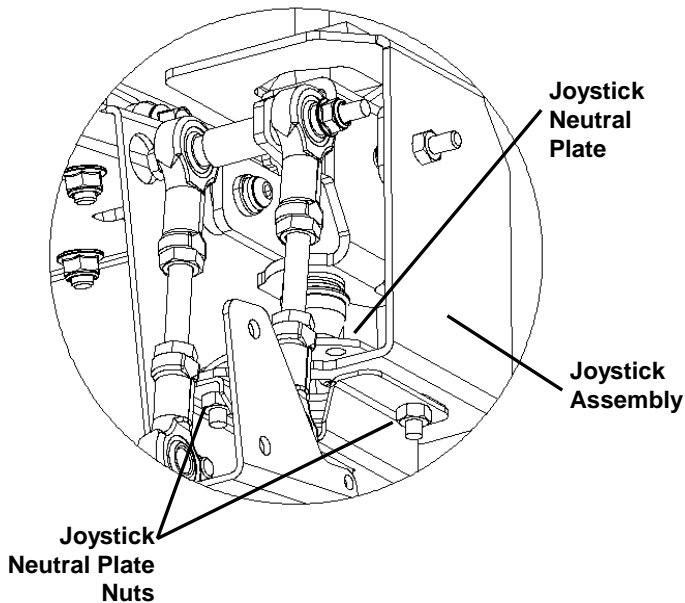

- B. Start the engine. With the Joystick Control Lever still in the down position move the Joystick Handle until both wheels stop rotating.
- C. Tighten the two nuts on the bottom of the Joystick Neutral Plate, being careful not to shift it out of position.
- D. Recheck neutral before placing the mower back on the ground. Then shut off the engine and remove the mower from the blocks.

## 3. JOYSTICK CONTROL LEVER SENSITIVITY ADJUSTMENT:

To change the sideways turning response, adjust as follows:

- A. Remove the right hand fender exposing the Joystick Control Lever assembly.
- B. Remove the cross bolt, nut, & spacers.
- C. For quicker reacting steering place the long, silver colored spacers toward the inside of the rod end ball joints and the shorter, gold colored spacers on the outside of the ball joints. For slower reacting steering place the short, gold colored spacers on the inside and the longer, silver colored spacers on the outside. All 4 spacers must be used when reassembling.

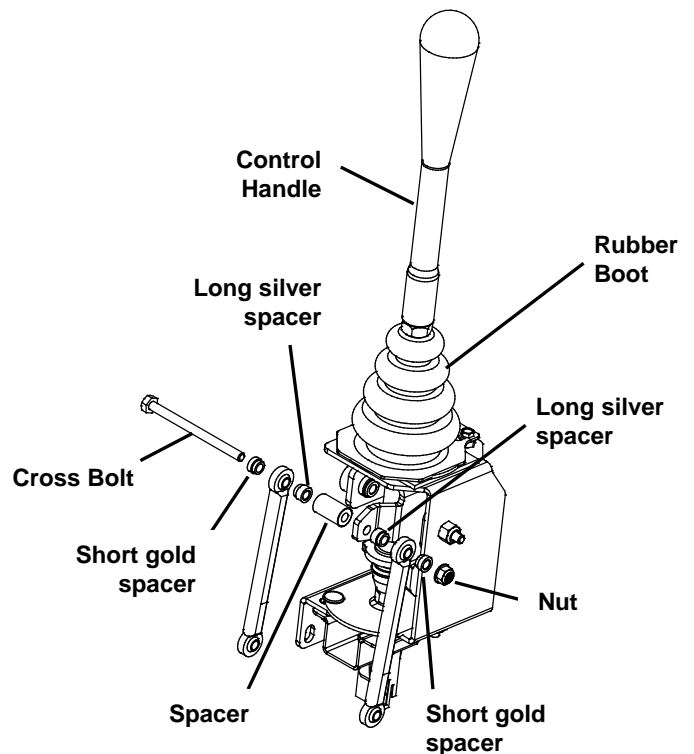

## TWINSTICK ADJUSTMENT

### 1. SETTING NEUTRAL:

- A. Each twin lever control is linked directly to the transmission control plate via an adjustable length ball joint rod-end linkage. Adjustment of these linkages is only required if the mower creeps with the twin lever control handles locked in the neutral position (out) while the engine is running and the park brake is off.
- B. To set neutral raise the drive wheels off the ground and stabilize the mower on blocks or jack stands.
- C. On the side that needs adjusting loosen the jam nuts on either end of the coupling nut that is on the lower end of the linkage and spin the jam nuts back a couple of turns. (Note that the bottom jam nut has left-hand threads.)
- D. Now start the engine and rotate the coupling nut until the wheel stops turning. Turn off the engine and retighten the jam nuts, then re-check with the engine running.

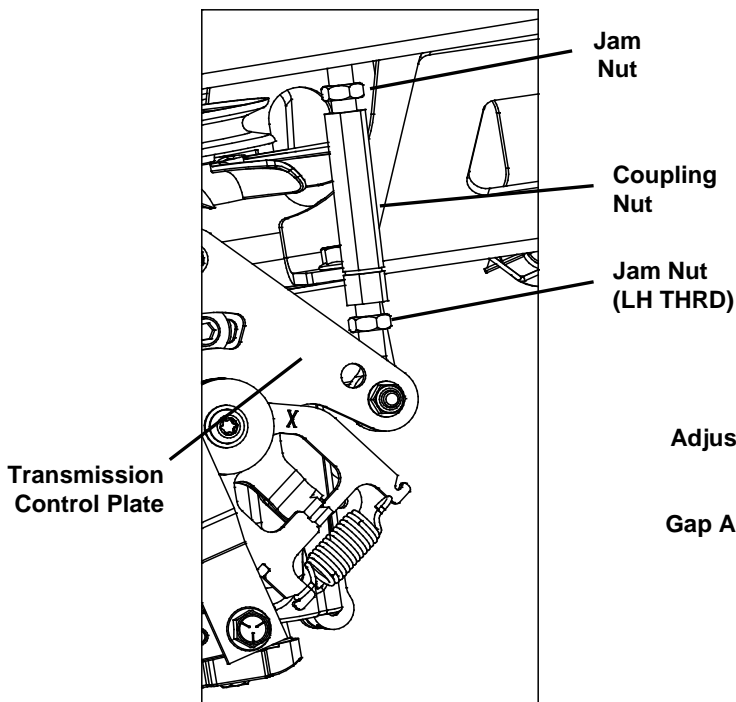

**NOTE:** It can help to fine tune the neutral setting by turning the coupling nut until the wheel just starts turning forward and again in reverse and then set it half way between the two points.

### 2. SETTING THE OPERATOR HANDLES:

- A. There are three positional adjustments for the operator hands. The length or height of the handles has two available positions. Mount the handles in the upper set of holes or the lower set of holes for maximum operator comfort.
- B. Adjust the handles fore and aft position before tightening the handle mounting bolts. The fore/aft position of the handles should be set such that they are aligned with each other while in the neutral position.
- C. Adjust the gap between the handles by rotating the adjustment bolt inside the twin lever control box. Loosen the jam nut and rotate the bolt so that there is about an inch gap between the ends of the operator handles when they are "in" (driving position). Make the height of the handles the same, or in line with each other. This may require adjusting both sides.

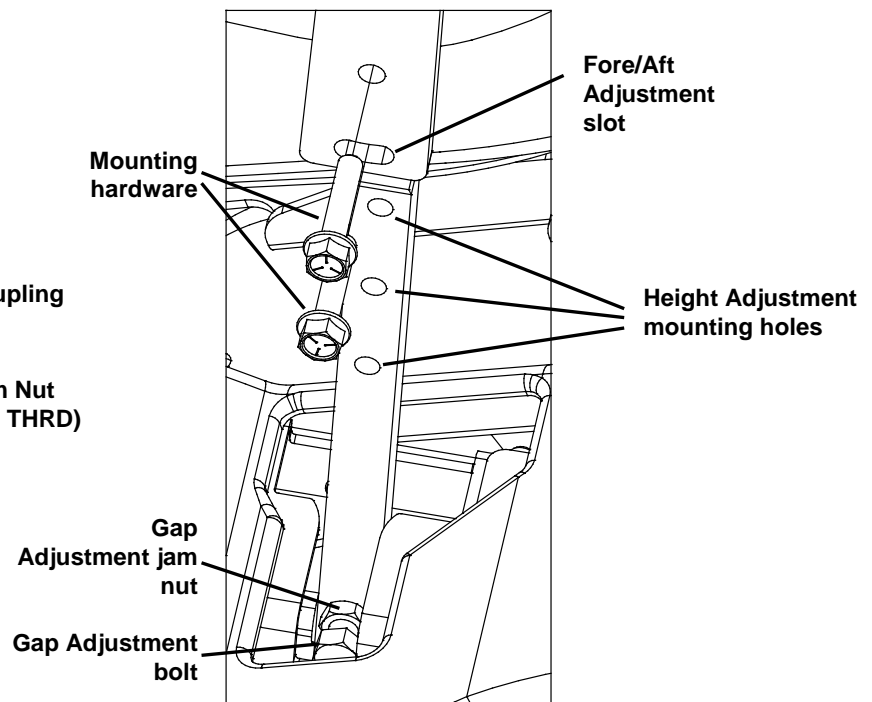

### 3. SETTING THE FORWARD TRACKING:

In a large open area, actuate the Twinstick Control levers into the full forward position. If the mower veers in either direction left or right, some adjustment is necessary. If the mower veers to the right, then the left transmission needs to be slowed down. If the mower veers to the left, then the right transmission needs to be slowed down.

- A. Stop the machine and shut off the engine.
- B. On the wheel that needs adjusted, turn the Tracking Adjustment Screw in until it contacts the stop, then turn screw ½ turn (slowing speed) increments, until the mower track straight.

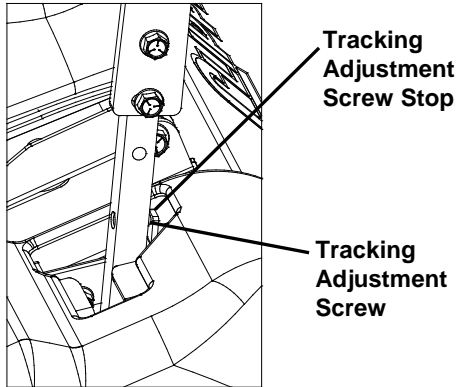

### HYDROSTATIC TRANSMISSION

Before each use, check to be sure that the cooling surfaces of the hydrostatic transmissions are clean. Excessive accumulation of oil, dirt, or trash may cause the transmissions to overheat.

**NOTE: NEVER WASH ACROSS THE VENTED CAP OR SHAFT SEAL AREA .**

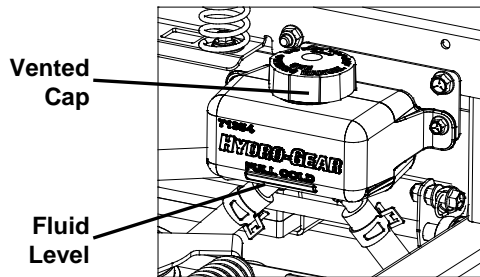

It is essential that the unit exterior be free from debris prior to doing any fluid maintenance.

#### 1. HYDROSTATIC TRANSMISSION FLUID CHANGE:

SAE 20W-50 engine oil has been selected for use by the factory and is recommended for normal operating temperatures. Each transmission holds a maximum of 74 oz. of oil.

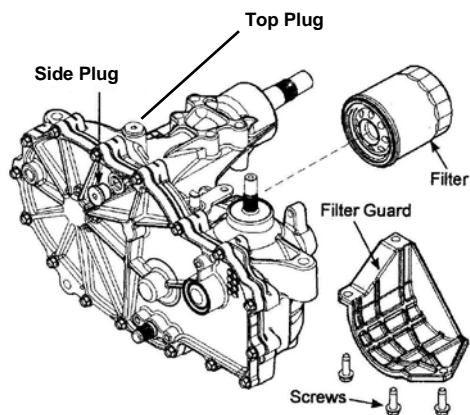

- A. Thoroughly clean the Transmissions around the fill plugs and the oil filter before removing.

- B. Set the park brake.
- C. Open the by-pass valve (Set to "Free Wheel"). See pg.10
- D. Remove the oil filter (Drains Fluid).
- E. Remove the top plug on the right side transmission (Torque to 180 in-lbs)
- F. Remove the side plug on the left side transmission (Torque to 180 in-lbs)
- G. After all the oil is drained out, replace the filter (use part # H-2567 when ordering from Country Clipper). Wipe off the filter base surface, apply a film of new oil to the gasket of the new filter and hand tighten ¾ to one full turn after the filter gasket contacts the filter base surface.
- H. Refill the transmission with the recommended oil through the expansion tank. When the oil level in the transmission reached the top or side plug port reinstall the plug and continue filling until the "Full Cold" line is reached on the expansion tank. Refilling each transmission will take approximately 2 quarts of oil.

**NOTE:** Due to the effect air has on efficiency in hydrostatic drive, it is critical that it be purged from the system.

These purge procedures should be performed any time a hydrostatic system has been opened for maintenance or oil has been added to the system.

### **IMPORTANT:**

Failure to purge system properly may cause one or all of these symptoms: 1) noisy operation. 2) Lack of power or drive after short term operation. 3) High operation temperature and excessive expansion of oil.

#### 2. PURGING PROCEDURES

##### Oil Hydrostatic Transmission

**NOTE:** Before starting procedure make sure the transmission is at the proper oil level. If it is not, fill to specifications.

The following procedures should be performed with the vehicle drive wheels off the ground then repeated under normal operating conditions.

- A. With the transmission in Free Wheel mode (see page 10 for details) and engine running, slowly move the directional control in both forward and reverse directions 5 to 6 times. As air is purged from the unit, the oil level will drop.
- B. Re-engage the transmission and with the engine running, slowly move the directional control in both forward and reverse directions (5 to 6 times). Check the oil level, and add oil as required after stopping engine.
- C. It may be necessary to repeat Steps A & B until all air is completely purged from the system. When the transaxle moves forward and reverse at a normal speed purging is complete.



## PROCEDURE FOR RAISING AND LOWERING THE DECK FOR SERVICING

### 1. RAISING THE DECK TO THE SERVICING POSITION:

- A. Position the front caster wheels so they are away from the deck (such as the tractor would be traveling in reverse).
- B. Remove the Cut Height Stop Pin and force the Cut Height Adjust Lever all the way down, passed the lowest cut height and pin the Cut Height Lever as shown.

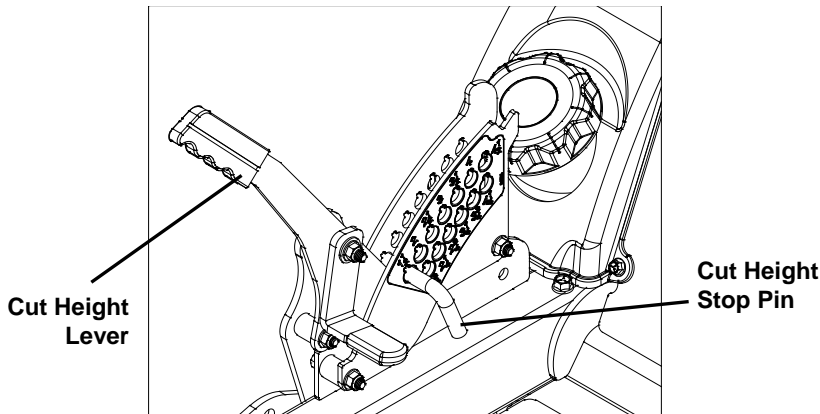

- C. Release the deck belt tension by carefully rotating the Deck Belt Tension lever on the deck. Now slide the deck belt off from the clutch pulley under the engine.

- D. Lift the nose of the deck until the deck is fully upright. Lifting the deck can be made easier if another person puts downward pressure on the rear of the mower.

### 2. LOWERING THE DECK TO THE OPERATING POSITION:

- A. Push the bottom (back) of the deck towards the rear of the tractor, and lower the deck until it rests on the ground.
- B. Place the engine-to-deck belt back on the clutch pulley. Check to make sure that the belt clears the frame and transmissions and that it runs above the Transmission Brace and is not caught on or hooked over something. Also ensure the belt is properly installed on all the deck pulleys and idlers.
- C. Re-apply the belt tension by carefully rotating the Deck Belt Tension Lever.
- D. Apply enough downward pressure to the Cut Height Adjust Lever to allow removing the Cut Height Stop Pin and remove the Pin. Move the Cut Height Adjust Lever to the desired cut height position and re-install the Cut Height Stop Pin.

**MOWER SHOWN IN  
OPERATING POSITION.**

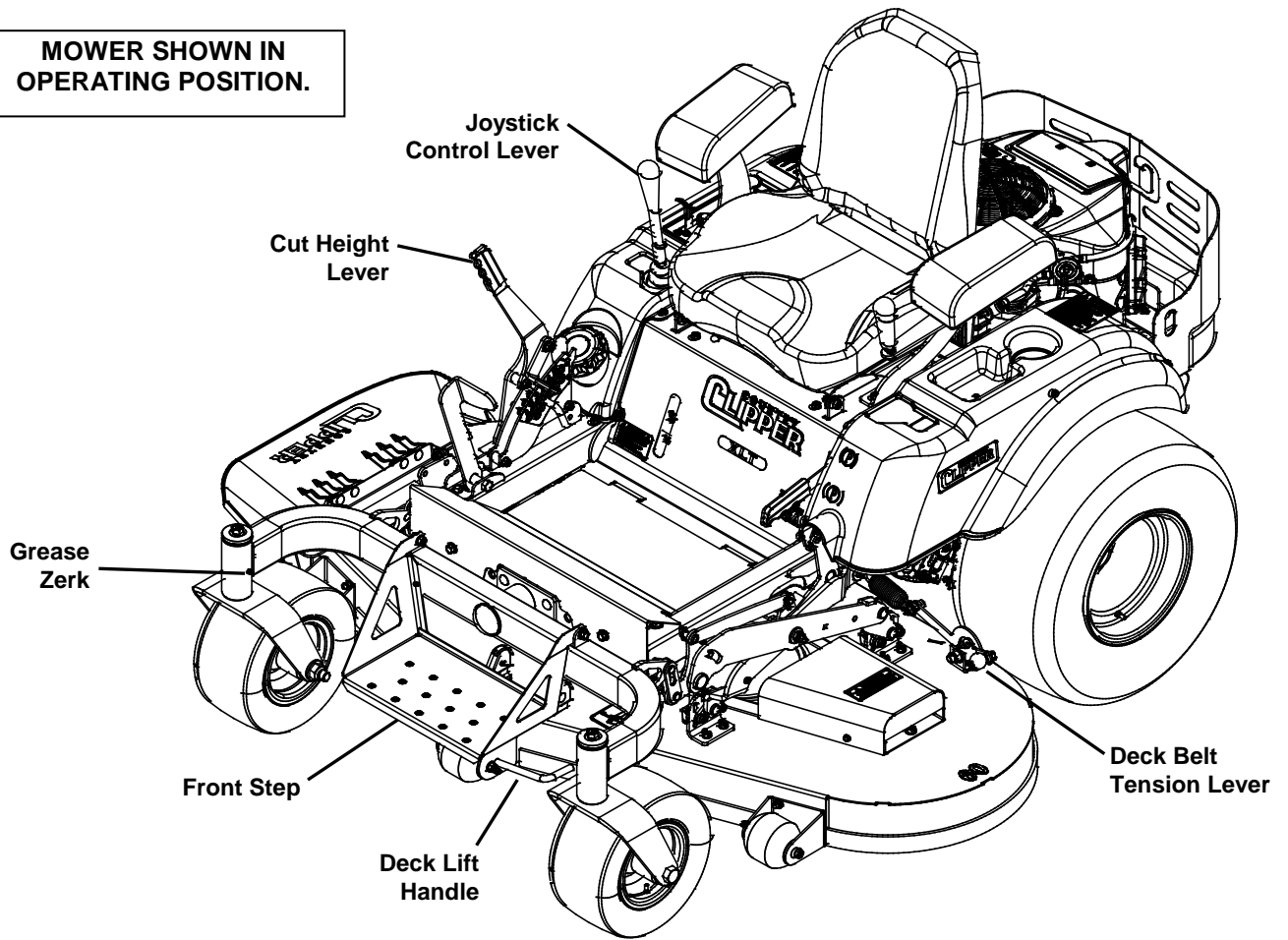

**MOWER SHOWN IN  
SERVICING POSITION.**

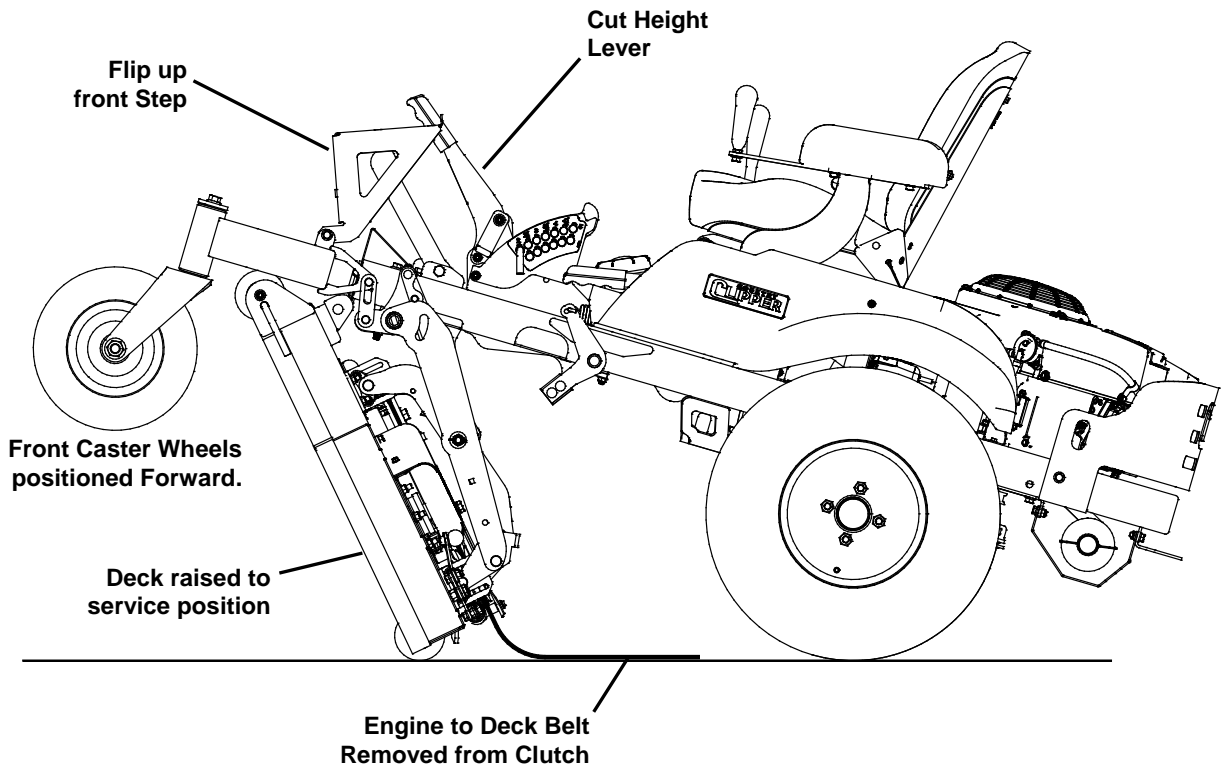

## LEVELING THE DECK

NOTE: *The Deck has been leveled at the Factory.*

*If leveling is needed, use the following procedures.*

1. Move the tractor to a hard, flat surface (i.e. concrete or blacktop), set Parking Brake.
2. Set the tire pressure on each of the four tires to 12-15 psi/ 83-103 kPa (make sure all four tires are equal)
3. Set the deck cutting height to the highest position and rotate the two outside blades by hand until one end of each outside blade points forward (toward the front of tractor)
4. Measure from the ground to the front blade tip of each outside blade. These measurements should be within 1/8" of each other. (NOTE: To simplify this measuring, an optional Blade Measuring Tool, part number 629-374A is available from your local "Country Clipper dealer")

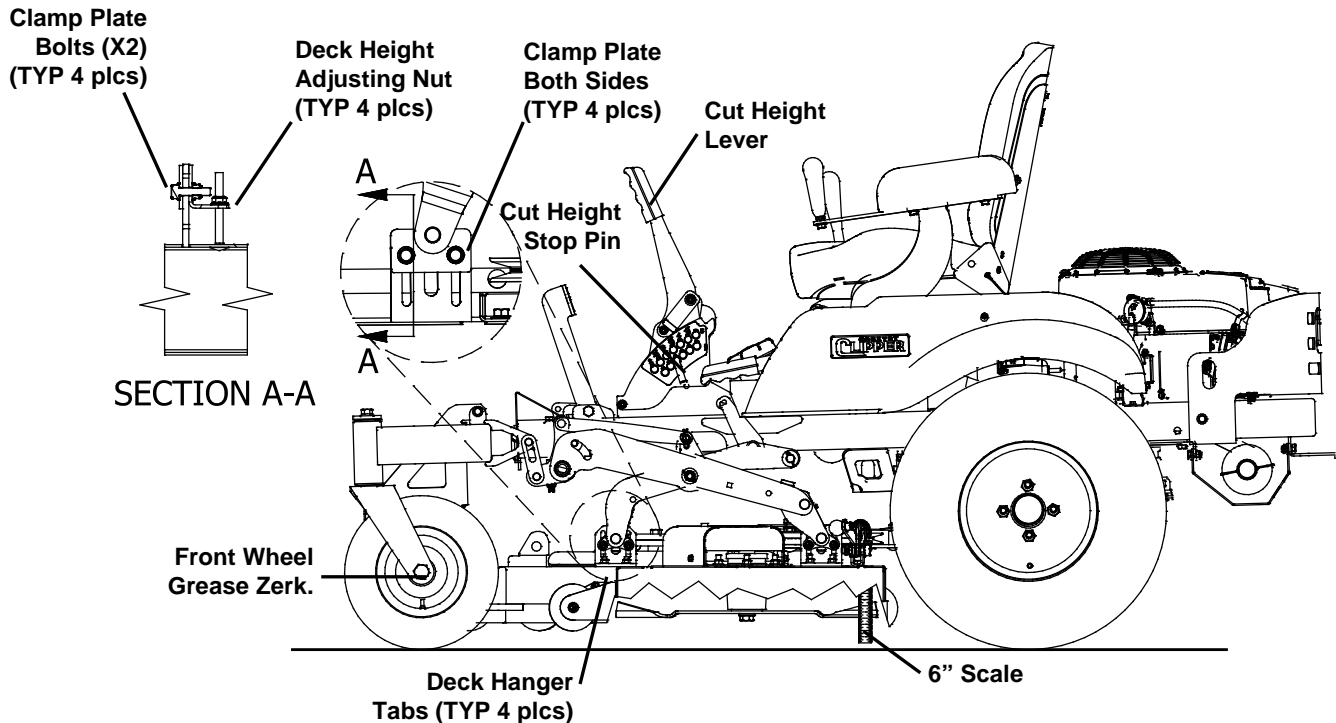

### **IMPORTANT:**

Do not attempt to set the deck cut height higher or lower than specified.

This could cause failure of the deck drive system.

5. If adjustment is needed loosen the 8 Clamp Plate bolts just enough so that the Clamp Plates are free to slide up and down on the Deck Hanger Tabs. Do not loosen too much, or the deck will sag.
6. Pin the Cut Height Lever in the 3" cut height position and rotate the Deck Height Adjusting Nuts to move the front leading point of the two outside blades to the blade height of 3".
7. Make sure the left and right side measurements are within 1/8" of each other. Now measure the rear blade tip height from the ground. Rotate the rear Deck Height Adjusting Nuts so that the rear measurement is 1/8" to 1/4" higher than the front measurement on each side.
8. Recheck all measurements, then tighten the 8 Clamp Plate bolts.

## TROUBLE SHOOTING CHECK LIST

1. ENGINE WON'T TURN OVER:
  - Mower blades engaged ----- disengage blades
  - Drive not in neutral ----- move Control Lever(s) to neutral position
  - Blown fuse ----- replace fuse
  - Dead battery ----- charge or replace
  - Solenoid ----- consult dealer
  - Ignition switch ----- consult dealer
  - Starter ----- consult dealer
2. ENGINE WILL TURN OVER BUT WON'T START:
  - No gas ----- refuel clean or replace fuel filters
  - Over or under choked ----- adjust choke
  - Spark plug not firing ----- check spark plug condition and reset gap\*
  - Carburetor maladjustment ----- reset carburetor adjustment\*
  - Ignition switch ----- consult dealer
  - Operator Presence Switch ----- consult dealer
3. HARD TO START ENGINE:
  - Fuel line clogged ----- clean fuel line and check fuel filter
  - Faulty fuel pump ----- consult dealer
  - Spark plug wire loose or grounded ----- check spark plug wires
  - Spark plug(s) faulty or improperly gapped ----- check spark plug condition and reset gap\*
  - Electronic ignition defective ----- consult dealer
  - Dirty or maladjusted carburetor ----- readjust carburetor\*  
consult dealer for carburetor service
4. ENGINE STARTS BUT CUTS OUT:
  - Water in gasoline ----- drain old gasoline and replace with new gasoline clean carburetor bowl
  - Clogged fuel line ----- check fuel filter, clean fuel line
  - Faulty fuel pump ----- consult dealer
  - Maladjusted carburetor ----- readjust carburetor\*
  - Engine dies when Control Lever(s) is move from "neutral" ----- parking brake set, release brake
5. ENGINE KNOCKS:
  - Low oil level ----- check and add oil
  - Ignition timing off ----- consult dealer
  - Fuel octane too low ----- drain and replace with higher octane gasoline
  - Overheated engine ----- shut off engine and allow to cool
6. ENGINE SOMETIMES SKIPS AT HIGHER SPEEDS:
  - Incorrect Ignition Timing -----consult dealer
  - Carburetor maladjusted -----readjust carburetor
  - Faulty spark plugs -----check spark plug condition and reset gap\*
  - Bouncing off seat safety switch -----slow down on rough terrain
7. ENGINE OVER HEATED:
  - Air intake screen or fins clogged -----clean intake screen and fins
  - Fuel mixture too lean -----readjust carburetor\*
  - Oil level too low or too high -----adjust oil level
  - Improper ignition timing -----consult dealer
  - Running engine too slow -----run engine faster (NOTE: Always mow at full throttle setting.)
8. ENGINE IDLES POORLY:
  - Carburetor maladjustment -----readjust carburetor
  - Improper spark plug gap -----check and re-gap plug\*
9. ENGINE BACKFIRES:
  - Carburetor maladjustment -----readjust carburetor\*
10. ENGINE RUNS BUT MOWER WON'T MOVE FORWARD:
  - Transmission locks in free wheel position -----put in lock position (see pg. 8)
  - Drive belt broken or slipping -----replace drive belt
  - Shift linkage disconnected -----reconnect
  - Transmission oil low -----consult dealer
  - Bad transmission -----consult dealer

## TROUBLE SHOOTING CHECK LIST CON'T

- 11. TRANSMISSION LOSES POWER OR TRANSMISSIONS OVER HEATS:**  
 Transmission damage -----consult dealer
- 12. MOWER TRANSMISSION DOES NOT ENGAGE RIGHT AND/OR LEFT HAND:**  
 Transmission Free Wheel engaged-----disengage Free Wheel  
 Loose or damage Control Linkage -----consult dealer  
 Low Transmission oil -----consult dealer
- 13. ENGINE STALLS WHEN BLADES ARE ENGAGED:**  
 Operator not on seat -----sit on seat  
 Faulty interlock system -----consult dealer  
 Bad blade spindle bearing -----consult dealer  
 Deck drive belt not properly routed -----reroute  
 Blades blocked by foreign material -----clean under deck
- 14. DECK BLADES WILL NOT ENGAGE:**  
 Blown fuse-----replace fuse  
 Faulty wiring -----consult dealer  
 Faulty electric clutch -----consult dealer

## BELT ROUTINGS

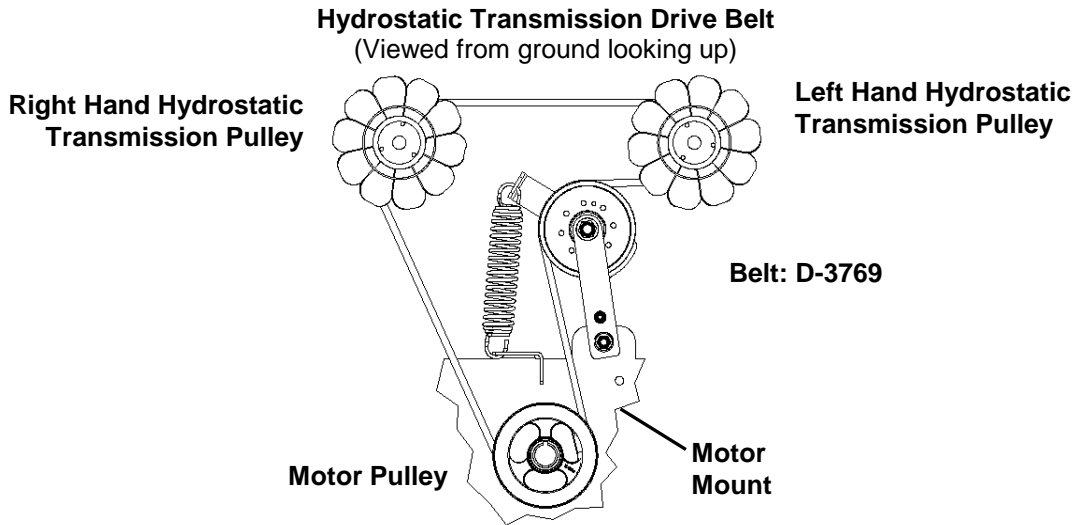

**XLT DECK BELTS:**

- 48" - D-3949
- 54" - D-3950
- 60" - D-3951

**CHALLENGER DECK BELT:**

- 52" - D-3776-W

**CHALLENGER DECK BELT:**

- 60" - D-3776-W

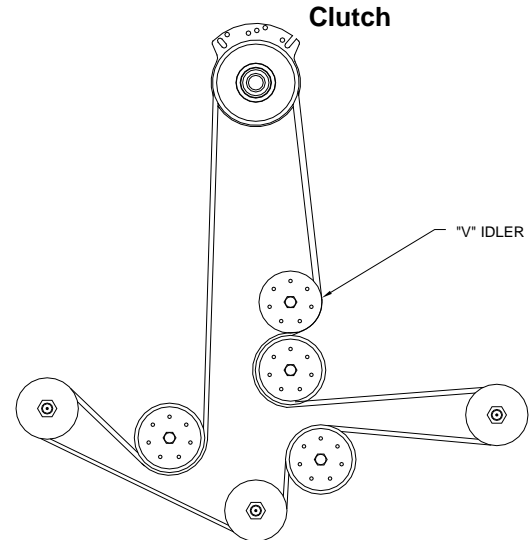
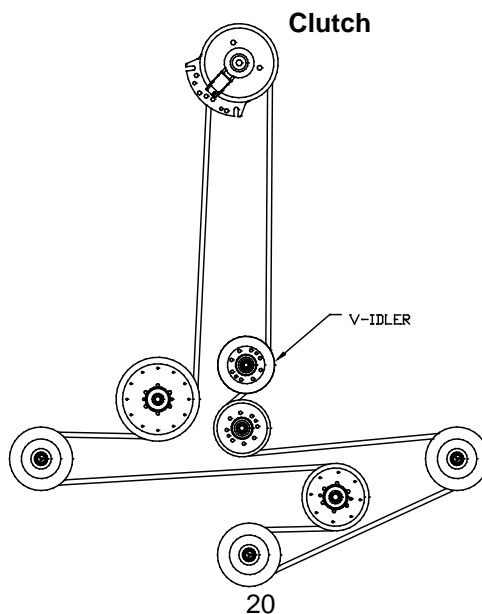
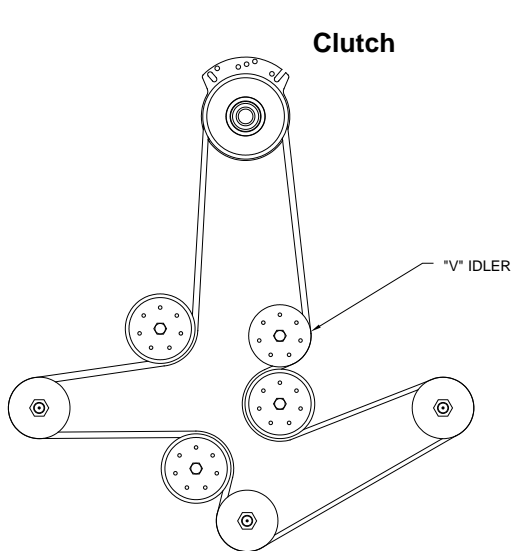





# Safety Instructions & Operators Manual



**XLT** C300

**CHALLENGER** D500

Country Clipper Division  
Shivvers Manufacturing Inc.  
613 W. English St.  
Corydon, IA 50060-0467  
Ph. 641-872-2544  
Fax. 641-872-1593